

**Building Information Modeling for Masonry
Phase II Project**

**Project 1, Masonry Unit Model Definition
Pankow Foundation Grant RGA#03-13**

Revised Final Report

**Development of Masonry Unit Database and Implementation of Data
Search and Export Tools
(Web Based Search System, and BIM Plugin 3D Module Exporter)**

Delivered to

**Charles Pankow Foundation
in support of the
Building Information Modeling for Masonry Initiative (BIM-M)**

**Georgia Institute of Technology
School of Architecture
Digital Building Laboratory**

**T. Russell Gentry, PI
Charles Eastman, co-PI
Shani Sharif, Graduate Research Assistant**

**Jeff Elder, Interstate Brick
Project Manager**

17 June 2015

Table of Contents

1. Executive Summary.....	3
2. Phase II: Status of the Masonry Unit Database	3
3. Phase III: Continued Development and Deployment of the MUD	9
4. Development of the Masonry Unit Database in accordance with BIM-M “Masonry Unit Model Definition” Project Proposal	11
5. Summary and Conclusions.....	13
6. Appendix A: Notes on Masonry Unit Naming.....	14
7. Appendix B: Masonry Unit Model Definition Report 1 (3 March 2014)	17
8. Appendix C: Masonry Unit Model Definition Report 2 (13 August 2014)	44
9. Appendix D: Masonry Unit Database Webinar (29 August 2014)	79
10. Appendix E: “Masonry Product Models for Building Information Modeling” Paper presented at 9th International Masonry Conference (2014)	128
11. Appendix F: “Masonry Unit Database Development for BIM-Masonry”, paper presented at 12th North American Masonry Conference (2015)	141

1. Executive Summary

This report represents the revised final deliverable from the Phase II BIM-M project to develop a masonry unit database or MUD. Section 2 of the report provide a narrative describing the progress on the overall project and the status of the MUD at the end of Phase II. Section 3 of the report provides the Georgia Tech perspective on future development and deployment of the MUD. Appendix A provides an extended discussion on the naming of masonry units, which has been identified as a key objective by industry professionals who are advising the BIM-M Initiative.

Section 4 of the report outlines the original Phase II MUD project proposal, and describes work completed in each area as envisioned by the proposal (awarded 8 July 2014). In some cases, the work has been more extensive than envisioned in the project proposal. In other areas, such as the inclusion of masonry accessories in the MUD, the project did not complete the work as originally intended, and the scope of work in these areas will be moved to Phase III.

Finally, the report has been revised to include the primary work products from the Phase II MUD project as appendices – so that readers of the report do not need to search for these documents in the BIM-M library or on conference websites.

2. Phase II: Status of the Masonry Unit Database

In the first part of the Phase II of the Masonry Unit Database (MUD) project, reported to BIM-M in our reports dated 3 March 2014 and 13 August 2014, we addressed the following aspects of the masonry industry and the need for a common data repository for masonry units:

- Classification of masonry materials at the detailed level
- Analysis of masonry projects workflows and the need for masonry unit information at each project phase
- Proposed BIM-M enabled masonry architectural project workflow using the MUD
- Identification of required exchanges in the workflow between different stage holders at different stages of the project
- Identification of main masonry attributes for the development of the database based the defined exchanges
- Development the ER (Entity-Relationship) model for MUD to represent the organization of the masonry semantic information as the basis for the development of SQL database

In the continuation of the process as part of the Phase II of the Masonry Unit Database development, the following advances have been achieved (Figure 1):

1. Translating the ER schematic diagram into SQL data base in Microsoft SQL server
2. Instantiated the MUD SQL database with about 90 sample masonry unit (clay brick and concrete masonry units), and testing the attribute requirements and dependencies
3. Developing a structure for representing ‘generic’ and ‘specific’ masonry units in MUD

4. Working with with Codifyd for the development of masonry product hosting and search website with the instantiation of hundreds of concrete masonry units as a proof of concept trial
5. Development of a BIM plugin with Dynamo for Revit, inquiring masonry unit data from MUD and generating BIM 3D geometry models

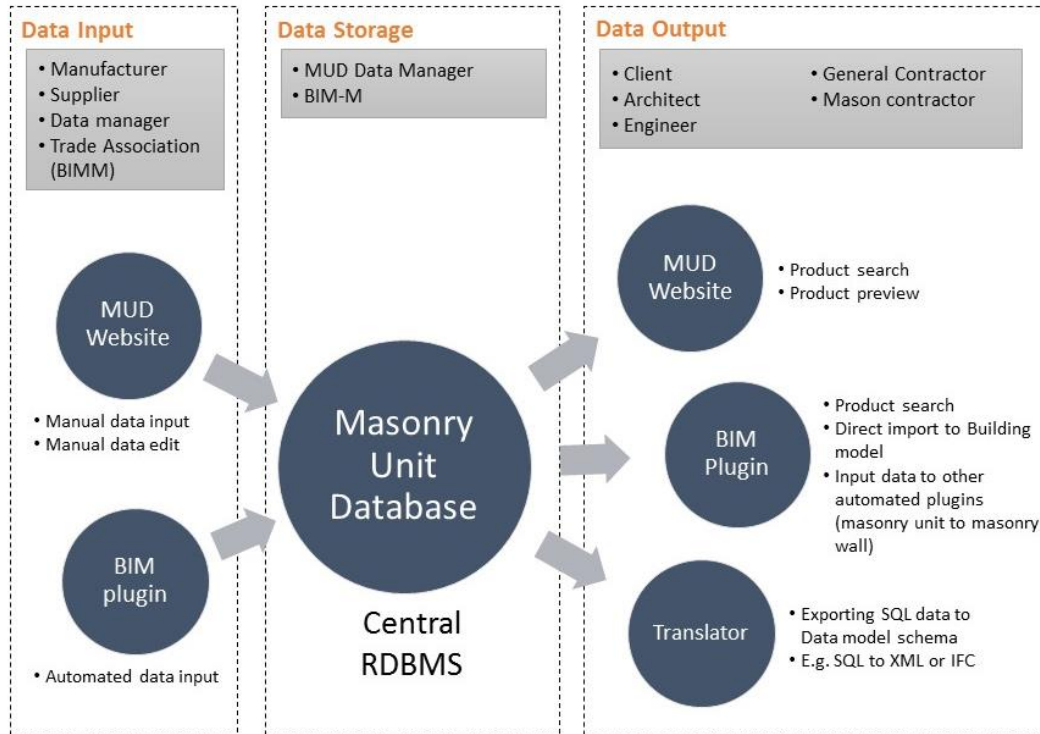

Figure 1: Main structure of MUD: RDBMS core, import and export tools

Physical design of MUD in SQL format, and Data Instantiation

As the main and center part of the MUD, a relational database is developed based on the organized masonry unit data model in ER model format. Using a RDBMS (Relational Database Management System), the SQL language was acquired for the development of MUD in the Microsoft SQL Server environment (Figure 2 and 3). The developed database includes the requirements needed for MUD logical and physical design choices and physical storage parameters, as well as detailed specification of data elements, data types, and indexing options. The MUD SQL database is composed of the following tables: Unit, Geometry, Material, Physical Properties, Color, Texture, Manufacturer, and Supplier.

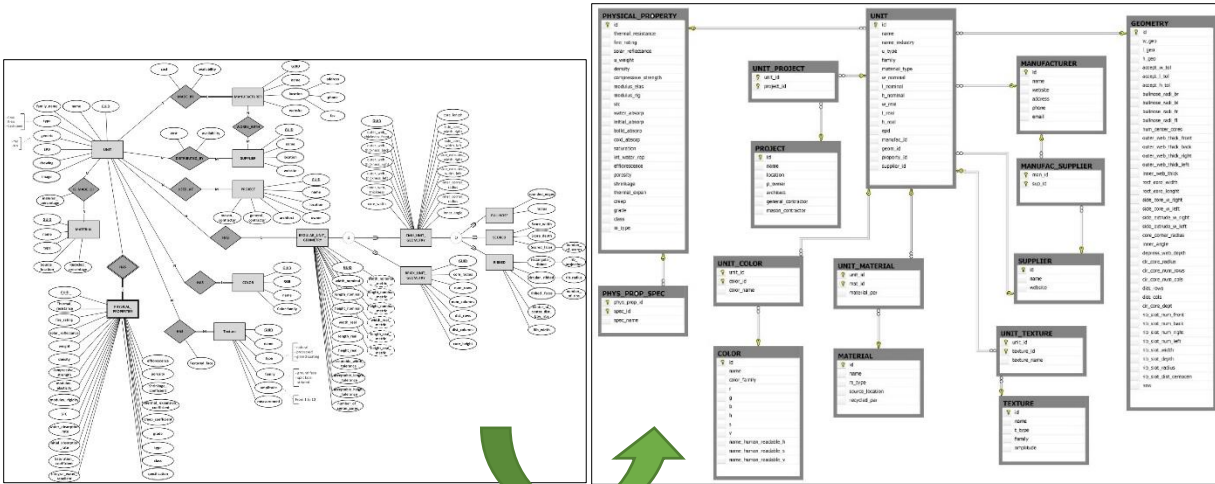

Figure 2: Adapting the MUD ER Model into SQL Format. Left ER Model, right auto generated table diagrams of SQL database

At the next stage of MUD physical design, the database was instantiated with data for about 90 masonry units (Clay Brick, and CMU), in order to test the data requirements and relationships. As a result, the database data structure was edited to be able to incorporate all possible masonry unit requirement and data formats (Figure 3).

id	name	name_industry	u_type	family	material_type	u_central	h_central	u_height	h_height	u_width	h_width	u_depth	h_depth	u_weight	h_weight	u_manufact	h_manufact
1	9416748-844-479-414-00404646F	7.5-8 Modular	7.5-8 Modular	The Brick	Clay	0.5000	8.0000	7.6250	7.6250	1.5000	1.5000	7.6250	7.6250	3.6250	3.6250	30863008-0422-407F-8F42-0270C35FE307	8E10ACAC3550
2	C5C27074A-41-4769-8367-02770CA738	4 x 3.5-8 12 Altus	4 x 3.5-8 12 Altus	Structural Brick	Clay	4.0000	12.0000	3.7500	3.6250	11.6250	11.6250	3.6250	3.6250	16.0000	16.0000	30863008-0422-407F-8F42-0270C35FE307	1A3C7A697804
3	E4C93076-D2C3-44F3-44D0-026F46C214D	4 x 2.5-8 16 Altus	4 x 2.5-8 16 Altus	Structural Brick	Clay	4.0000	16.0000	2.7500	3.5625	15.5625	15.5625	3.5625	3.5625	16.0000	16.0000	30863008-0422-407F-8F42-0270C35FE307	A8072586-46C3
4	027E5558-4E78-4584-8284-01918628C10	Reg. 3/8x16 Sash	Reg. 3/8x16 Sash	Architectural Brick	Sash	0.0000	16.0000	0.0000	7.6250	15.6250	7.6250	0.0000	0.0000	16.0000	16.0000	E27D0668-4244-4384-AB81-07C280C3E919	383C2F122046
5	1F098F91-028E-4208-8D84-6E40035AA643	10 x 3.5-8 16 Altus	10 x 3.5-8 16 Altus	Structural Brick	Clay	10.0000	16.0000	2.6250	2.6250	15.5625	15.5625	3.6250	3.6250	16.0000	16.0000	30863008-0422-407F-8F42-0270C35FE307	48E148C0-1992
6	BE7679A-89E4-A4C-3E70-079C6F4C0A3	2 1/4 Modular	2 1/4 Modular	Facing Brick	Clay	4.0000	8.0000	2.0000	3.6250	7.6250	2.0000	3.6250	3.6250	16.0000	16.0000	30863008-0422-407F-8F42-0270C35FE307	8C36258D-99F8
7	221AC26A-4792-4210-4271-719F16C1D0E4	4 x 2 1/4 16 Altus	4 x 2 1/4 16 Altus	Structural Brick	Clay	4.0000	16.0000	2.7500	3.5625	15.5625	2.7500	3.5625	3.5625	16.0000	16.0000	30863008-0422-407F-8F42-0270C35FE307	C1971878-789D
8	4AC7306-48E7-4228-60E6-1818F181846E	4 x 3.5-8 16 Altus	4 x 3.5-8 16 Altus	Structural Brick	Clay	4.0000	16.0000	3.7500	3.5625	15.5625	3.6250	3.6250	3.6250	16.0000	16.0000	30863008-0422-407F-8F42-0270C35FE307	30281A7A442E
9	2C1A4784-64E0-40C2-9E8B-1D079C846CFC	4 x 2 1/4 12 Altus	4 x 2 1/4 12 Altus	Structural Brick	Clay	4.0000	12.0000	3.0000	3.6250	11.6250	2.7500	3.6250	3.6250	16.0000	16.0000	30863008-0422-407F-8F42-0270C35FE307	384438C0-5285
10	E0378E4-1E7-408C-8E7F-8E9F088F78E	10 x 2 1/4 16 Altus	10 x 2 1/4 16 Altus	Structural Brick	Clay	8.0000	16.0000	2.2500	2.5625	15.5625	2.2500	2.5625	2.5625	16.0000	16.0000	30863008-0422-407F-8F42-0270C35FE307	E43D858B-C80C
11	3C8080E1-82C8-408D-894D-01918628C10	2 3/4 Modular	2 3/4 Modular	The Brick	Clay	15.5000	8.0000	2.7500	0.0000	7.6250	2.7500	0.0000	0.0000	16.0000	16.0000	30863008-0422-407F-8F42-0270C35FE307	53E2594F-5403
12	4E110248-5E24-4FEF-9031-270C18F9353C	2 5/8 Modular	2 5/8 Modular	Facing Brick	Clay	4.0000	8.0000	2.7500	3.6250	7.6250	2.6250	3.6250	3.6250	16.0000	16.0000	30863008-0422-407F-8F42-0270C35FE307	7449158D-0340
13	2E855858-45D7-4D88-8C46-2A8C8187730F	8 x 2 1/4 16 Altus	8 x 2 1/4 16 Altus	Structural Brick	Clay	8.0000	16.0000	2.2500	2.5625	15.5625	2.2500	2.5625	2.5625	16.0000	16.0000	30863008-0422-407F-8F42-0270C35FE307	E43D858B-C80C
14	48548184-8842-4889-8D89-2C30C32889F6	2 5/8 Engspur	NULL	Facing Brick	Clay	4.0000	16.0000	2.7500	3.5625	15.5625	2.6250	3.5625	3.5625	16.0000	16.0000	30863008-0422-407F-8F42-0270C35FE307	A8072586-46C3
15	F3384285-2488-48E5-4413-31056488D3D0	8 x 2 5/8 12 Altus	8 x 2 5/8 12 Altus	Structural Brick	Clay	4.0000	12.0000	2.7500	3.6250	11.6250	2.6250	3.6250	3.6250	16.0000	16.0000	30863008-0422-407F-8F42-0270C35FE307	82C3888B-998F
16	1F9A3D58-52E8-4381-8578-30C88E6E3F84	3 5/8 Roman	3 5/8 Roman	Ublty	Clay	4.0000	12.0000	3.7500	3.6250	11.6250	3.6250	3.6250	3.6250	16.0000	16.0000	30863008-0422-407F-8F42-0270C35FE307	1A3C7A697804
17	C5E6A8-0D60-4FCB-471A-3E8A8E3F1CF2	4 x 5 5/8 16 Altus	4 x 5 5/8 16 Altus	Structural Brick	Clay	4.0000	16.0000	3.6250	3.6250	15.5625	3.6250	3.6250	3.6250	16.0000	16.0000	30863008-0422-407F-8F42-0270C35FE307	8085A8BC-EEEE
18	CF0A32EA-029F-4541-868F-30D602927150	8 x 2 1/4 12 Altus	8 x 2 1/4 12 Altus	Structural Brick	Clay	8.0000	12.0000	2.2500	2.5625	11.6250	2.2500	2.5625	2.5625	16.0000	16.0000	30863008-0422-407F-8F42-0270C35FE307	24C32A31-0199
19	F546F2C-0262-420A-430A-0744AC14F6E2C2	4 x 7 5/8 16 Altus	4 x 7 5/8 16 Altus	Structural Brick	Clay	4.0000	16.0000	7.7500	3.5625	15.5625	7.6250	3.5625	3.5625	16.0000	16.0000	30863008-0422-407F-8F42-0270C35FE307	E395519C-0266
20	108E158E-45FC-4762-489D-4D042785F048	Reg. 3/8x16 Sash	NULL	Architectural Brick	Sash	0.0000	16.0000	0.0000	7.6250	15.6250	7.6250	0.0000	0.0000	16.0000	16.0000	E27D0668-4244-4384-AB81-07C280C3E919	C45F3E79-503C
21	ADDAC8C3-A5A2-4824-4E26D174935E	2 3/4 Engspur	2 3/4 Monarch	The Brick	Clay	0.7500	16.0000	2.7500	3.6250	15.5625	2.7500	3.6250	3.6250	16.0000	16.0000	30863008-0422-407F-8F42-0270C35FE307	F387488E-479D
22	E29488F1-A482-4843-8403-4F95DC1D481A	2 3/4 Modular	2 3/4 Modular	Facing Brick	Clay	4.0000	8.0000	3.0000	3.6250	7.6250	2.7500	3.6250	3.6250	16.0000	16.0000	30863008-0422-407F-8F42-0270C35FE307	8C084D11-49C-

Figure 3: A sample view of populated data in MUD

Generic vs. Specific Masonry Units

We anticipate that MUD to have capability to store information of both 'generic' and 'specific' masonry units. The generic units that will be represented at the current development stage of MUD will be represented by the information provided by masonry association, with standard unit sizes, geometric shapes, color families and generic textures, but with no information regarding specific manufacturers of these units. Representation of generic units would assist the general product selection and comparison for architects and engineers, as well as creating the base for modeling and representation of masonry

units in BIM software tools as part of masonry wall systems. In the next stages of the MUD development, the database could be potentially enhanced with ‘specific’ masonry unit information with detailed information of manufacturers and suppliers of each masonry unit type. The specific unit information would provide the basis for E-Commerce: detailed product variations and specifications, selection of local products, availability, cost comparison and estimation, and finally product purchasing

In the development of schema model for MUD, we have implemented the required features for representing both generic and specific units. For this purpose, in MUD the Unit table is linked to itself. The attribute ‘generic_id’ would be a foreign key in the table that references the ‘id’ attribute (primary key) of the same table. We also have a separate table, Manufacturer, which contains the main information about the manufacturer company, and this data is linked to UNIT table with a Foreign Key. This structure would make it possible to represent both generic product units with no information regarding the manufacture in the database, as well as representing specific product representing a product object instance. For *generic* product units, the ‘manufacturer_id’ attribute (foreign key to Manufacturer table) would be NULL, the entity will be marked as *generic*, and the ‘generic_id’ attribute have to be always NULL for this entity. On the other hand, the entities that have manufacturer data, should have a value for ‘generic_id’ attribute, to link them with their generic counterpart (Figure 4).

In addition, the generic product entity would be linked to the other tables of the database, having a copy of attributes from geometry and the basic set of values for physical properties, but no data regarding the manufacturer, or pricing. It would be possible for specific entities to edit certain information that are inherited from the generic product. A complete set of constraints has to be defined to specify which attributes can be modified and in what range, so that this model can still satisfy the replacement requirements for its generic mate.

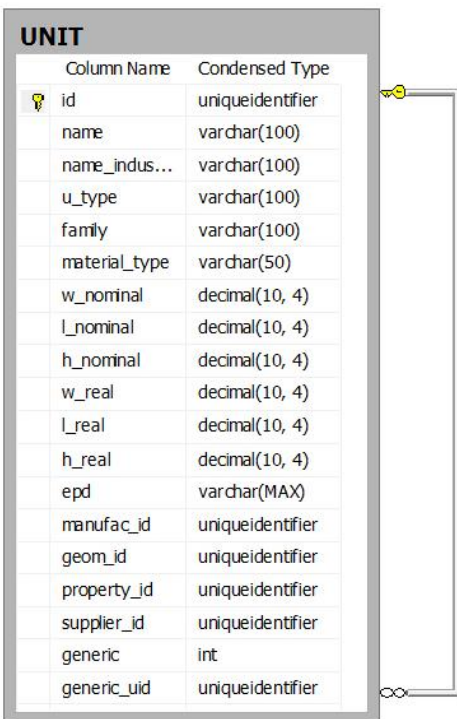

Figure 4: Unit Entity Table diagram in Microsoft SQL Server database for masonry units

After the design and development of the MUD SQL database, the next major priority is to create data access options for users of the base (Figure 1). These options are discussed in the two following sections:

Development of MUD hosting and search website

There are two main access tools that is envisioned for MUD, first a web-based access platform that would provide search, view and compare of masonry units for the users. As the developer of product hosting and search website, CODIFYD company (www.codifyd.com), incorporated the developed SQL MUD database by Georgia Tech team, into their XML based search tool, Bridge. They populated the new web-based version of MUD with more than 1000 modules from two main masonry manufacturers with 3D, and color and texture images. A sample result of a masonry unit search in the MUD website is shown in figure 5.

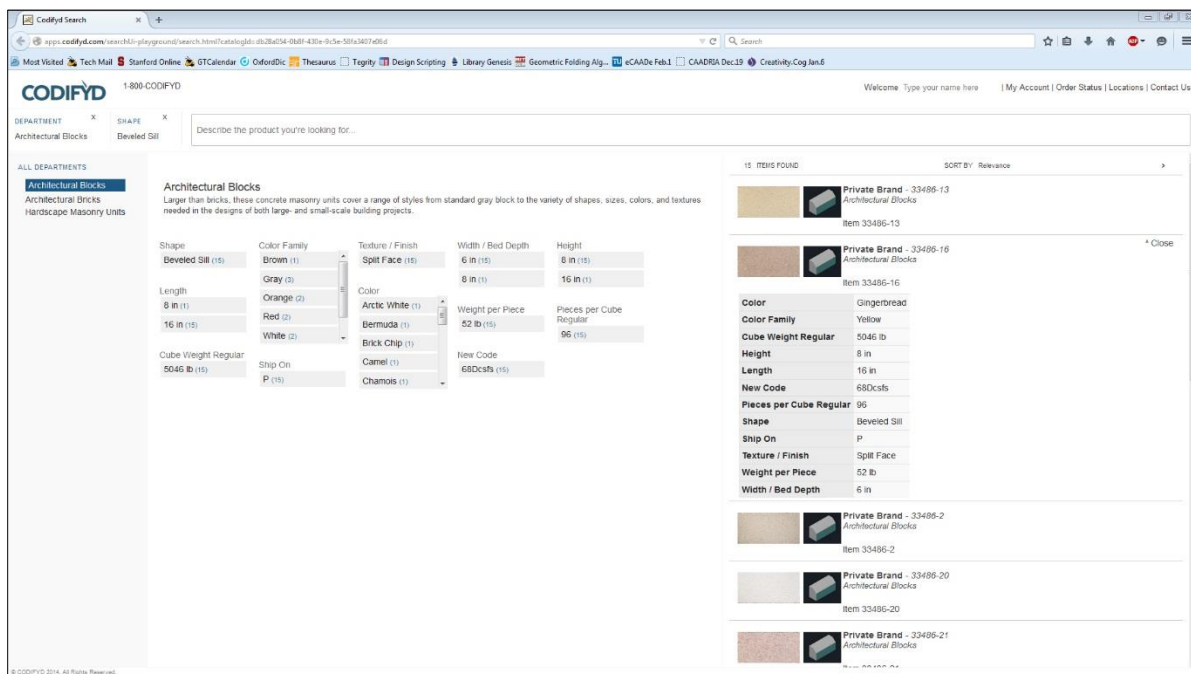

Figure 5: MUD database web search, developed by CODIFYD

Development of MUD BIM Plugin

The second option for exporting data from MUD is the direct transport of inquiry result from the database to a BIM tool in form of 3D geometric representation, which can be enhanced with color and texture data and other representable attributes in BIM tools, such as Autodesk Revit Architecture. We acquired Dynamo, as a special plugin developer for BIM and specifically Revit. The developed MUD plugin has the capability to connect to SQL Management systems and run SQL queries to import data from the database into the Dynamo environment, generated 3D modules based on imported data, and export the geometry as a Revit family object (Figure 6 and 7).

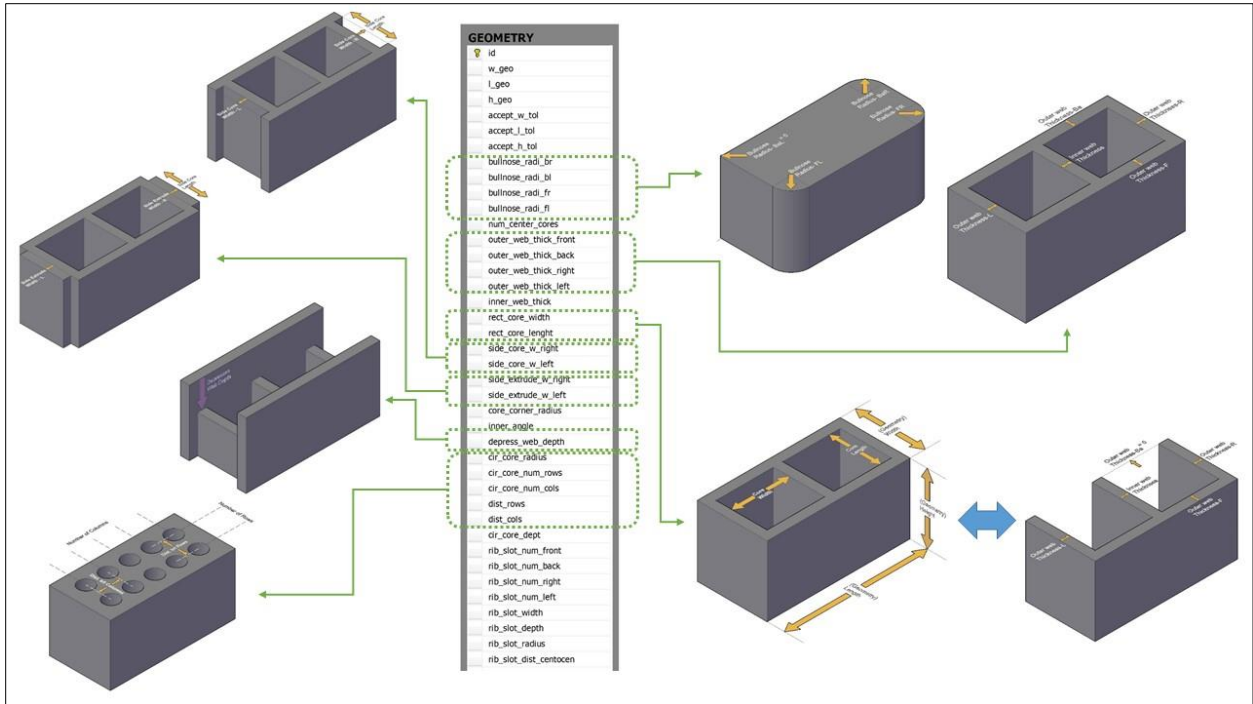

Figure 6: Attributes defined in MUD for parametric geometric definition of masonry modules, both clay brick and CMU

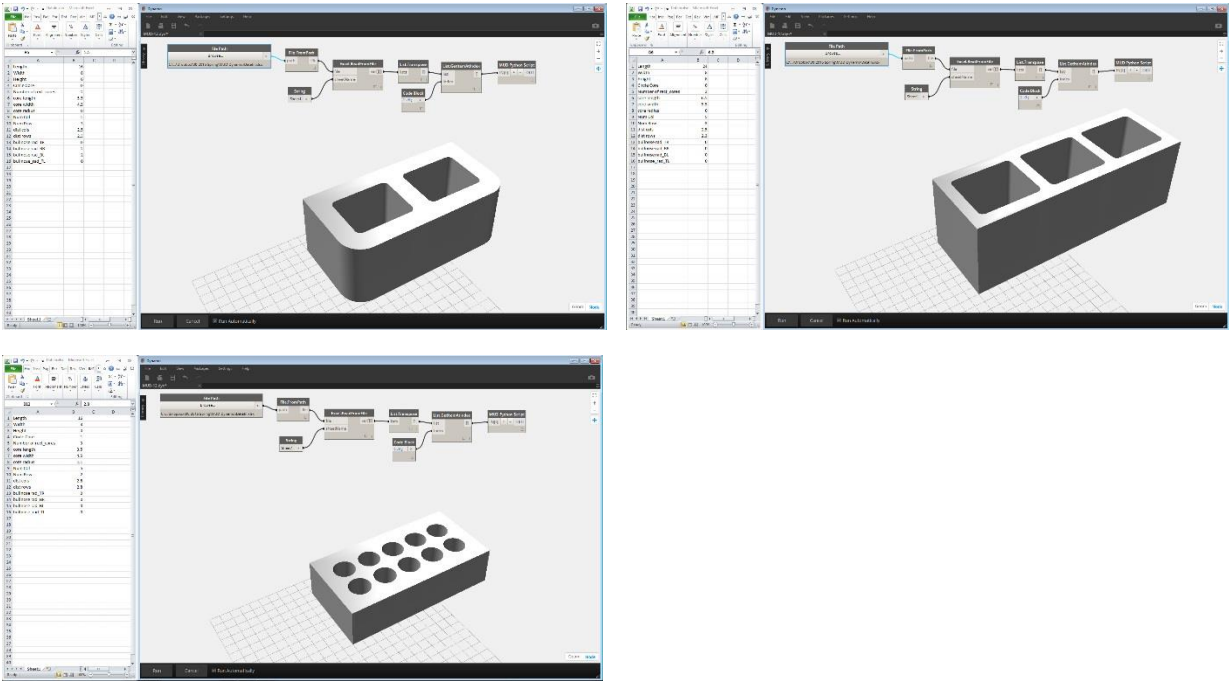

Figure 7: MUD masonry unit 3D generator in Revit Dynamo environment. Three different modules generated based on different queries from MUD

3. Phase III: Continued Development and Deployment of the MUD

We are in the process of working with BIM-M leadership to develop a scope of work for Phase III of the Masonry Unit Database project, which will lead to commercialization of the MUD. From the Georgia Tech perspectives, the steps that should be considered in this process are as follows.

1. Engage the data storage host companies for the MUD:

As one of the main aspects of MUD project realization, the masonry data provided by masonry manufacturers and suppliers has to be organized stored by a data storage host company. Identification and cooperation with potential host companies is an important step in the development of the MUD. Potential hosts such as Autodesk SEEK and ARCAT are specific to the building products industry. In general these sites do not provided detailed product information on the unit level. Our Phase II partner, Codifyd, demonstrated a masonry-specific solution that contained a high level of information that was drawn from the database. This is both a technical and industry trade solution, so the selection of a host must be made with both considerations in mind.

2. Develop policies for managing information in database:

A system for managing the association between generic units provided by industry trade associations and specific units sold by manufacturers needs to be implemented. In this way, the MUD can contain a rich assortment of masonry units, including geometries with both color and texture, which can be mapped to specific units sold by industry participants. This could be one way of promoting the MUD in the short term, while we wait for individual masonry producers to implement their version of the MUD.

3. Naming/classification systems for masonry systems:

Similar to AISC steel shapes, that have a clear naming and classification system that is accepted and used by all the stakeholders, masonry units also would benefit immensely from a normalized coherent naming/classification system. This was identified as a high-priority activity at the January 2015 meeting at Georgia Tech. The best naming solution would be a unique identifier that is both human-readable as well as machine-readable. Georgia Tech has identified three key aspects that should be part of the naming convention:

- Material system
- Nominal dimensions
- Unit family relationship

In future discussions with the Masonry Supplier Working Group, we expect to determine if other attributes should be embedded with the product name. See Appendix A of this document for a short description on the development of machine-readable names for masonry units.

4. Implement parametric capabilities in different BIM-CAD and scheduling environments:

Per the example we developed for a BIM plugin in the Dynamo-Revit environment, the capabilities for inquiring, transferring and translating MUD data into native BIM model structures should be implemented in additional BIM-CAD and scheduling environments: Revit, Rhino, Sketchup, AutoCAD, Tradesmen's and CADBlox. This parametric generation needs to be extended to create very lightweight models (nominal dimension without internal geometry) as well as highly detailed geometry for virtual mockups and 3-D rendering.

5. Coordinate with existing suppliers of masonry software:

The capabilities of the current masonry software tools such as CADBlox and Tradesmen's has to be taken into account in the completion steps of MUD development. A data inquiry option should be provided for these software tools.

6. Incorporate parametric generated units in BIM wall assemblies:

The main outcome of the MUD in BIM environment would be the incorporation of masonry unit geometry models in different LOD levels into BIM masonry wall assemblies, including different masonry units and arrangements. This is an important aspect of the Phase II and Phase III masonry wall project and BIM-M specification project.

7. Add custom masonry units to the database

At the current stage, MUD just represents masonry units with regular geometry, including clay brick and CMU. However, MUD should have the capability to incorporate all range of masonry units with custom and one of a kind geometric shapes which would include cut stone, and cast stone. The infrastructure for representing these units in the database has to be designed and implemented.

8. Extend the database to include masonry accessories, mortar, grout, ties, joint reinforcement

The database should be extended to masonry accessories. The current data model focuses on the attributes of masonry units, and so the schema will need to be extended to include the attributes of accessories, as well as the dependencies between units and accessories.

9. Add veneer and adhered products as the supplementary part of the database

Manufacturers have asked whether novel masonry materials such as thin brick, landscape units, and adhered masonry products can be included in the database. This is possible, but the attributes of such products needs to be considered carefully as we move forward. Our relationship with Codifyd could well be critical as we try and develop a data model that spans across relationship sets (a process known as "bridging" in the database industry).

4. Development of the Masonry Unit Database in accordance with BIM-M “Masonry Unit Model Definition” Project Proposal

In this section of the report we address specific tasks from the Phase II MUD project proposal and identify how these tasks have been addressed. This section has been included at the request of BIM-M leadership to assist them in identifying areas where emphasis should be placed in ongoing work in Phase III. Where possible we provide references to previously published BIM-M reports or publications. This section follows the detailed outline of the Phase II MUD proposal with the response highlighted in blue.

1. Masonry Supplier Input

- a. **Survey masonry unit suppliers to determine information that should be included in the model definition.**

Survey performed in the Summer 2012 and also as part of the Masonry BIM Benchmark Project Report 1, June 2014. The MSWG under the leadership of Jeff Elder provided a spreadsheet of attributes for clay and concrete units. Also our team had conference calls with masonry manufacturers such as Boral, Oldcastle and New Holland (now York) to understand their needs for masonry product representation.

- b. **Review earlier effort by the BIA to develop a masonry unit infrastructure.**

Brian Trimble of BIA provided meeting notes from prior discussions within BIA on the development of BIM models for brick masonry. The information was helpful and was helpful and was integrated into the Phase II MUD effort.

- c. **Develop scenarios of use (workflows) of masonry information in masonry supplier internal processes**

Workflow discussed in Report 1, dated 3 March 2014 (see Appendix B, Section 4)

2. Masonry Customer Input

- a. Survey architects and engineers to identify masonry information that they would wish to receive electronically from masonry suppliers - and the formats in which such information should be provided.

Survey performed in the Summer 2012 and Masonry BIM Benchmark Project Report 1, June 2014. Also met with Atlanta area design professionals (LAS Architects, THW Design, Perkins + Will, Cooper Carry) to determine their need for and use of masonry product information.

- b. Survey mason contractors to identify masonry information that they wish to receive electronically from masonry suppliers - and the formations in which such information should be provided.

Survey performed in the Summer 2012 and Masonry BIM Benchmark Project Report 1, dated 19 June 2014

- c. Develop scenarios of use (workflows) for masonry unit data interoperability between suppliers, architects, engineers, and contractors

Workflow discussed in report 1, Mar. 2014 (Appendix A, section 4)

3. Unit Selection: identify 10 common masonry unit types from the following industry trade groups.

- a. Brick Industry Association
- b. Cast Stone Institute
- c. National Concrete Masonry Association
- d. Western States Clay Products Associations

Clay brick and CMU Unit Types discussed in Report 2, dated 13 August 2014 (Appendix C, section 6.5.2. Geometry). Cast stone units with fixed dimensions are accommodated in the

- current data model. Cast Stone Units to be further accommodated in Phase III.*
4. Accessory Selection: identify up to 20 common masonry accessories used in conjunction with the masonry units identified in the previous task. Identify geometric, supplier, and standards attributes necessary for representing and selecting these accessories.
Masonry accessories were not addressed in the Phase II project and should be included in the Phase III MUD and Masonry Wall Model Definition / Specification projects.
 5. Data Model
 - a. Review and critique existing internal data models used by masonry manufacturers in MRP and other systems.
 - b. Review existing construction industry data models such as those promulgated by CSI, ASTM, and the buildingSmart Alliance.
Existing construction industry data models were discussed in in the MUD Report 1, dated 3 March 2014 (Appendix B)
 - c. Plan for compatibility with IFCs and IFDs, CSI OmniClass and ASTM Unifonnat II (standard database formats developed for use in I31M, classification systems, specifications, quantity take offs, and cost estimating).
Classification and interoperability compatibility was discussed in in Report 1, dated 3 March 2014 (Appendix B)
 - d. Plan for compatibility with current masonry-specific software (e.g., Tradesman),
Software compatibility was discussed in Report 2, 13 August 2014 (see Appendix C). This proposed planning is based on extensive discussions with Tradesmen's, CADBLOX and others.
 - e. Ram Elements and non-masonry specific applications (e.g., RS Means).
Software compatibility with a larger range of softwares was discussed in Report 2, dated 13 August 2014 (Appendix C)
 - f. Review technical and academic literature on building product data modeling and geometric modeling for masonry, including the following possible modeling options for masonry unit geometry.
Literature review in both Report 1, 3 March 2014 (Appendix B) and Report 2, 13 August 2014 (Appendix C)
 6. Develop interface requirements for the input of new and custom masonry types
The prototype web site created by Georgia Tech included for internal use included a simple front-end for the entry of units. In the future it is likely that a data bridging process such as that used by Codifyd will be used to bring manufacturers data into the MUD.
 7. Prototype initial data model.
MUD Data Model was discussed in Report 2, dated 13 August 2014 (Appendix C) and the SQL is discussed in detail in this report in Sections 2 and 3.
 8. Instantiate 40 masonry units into the prototype data model.
Data instantiation discussed in this report, Section 2.
 9. Deliver data model schema to stakeholders for their review and potential input of additional masonry units
MUD development was presented and discussed at the BIM-M Symposium, in April 2015
 10. Develop workflow method for the development and insertion of new masonry units into the data model
Discussed in the future steps section of this report, Section 3.
 11. Revise data model based on stakeholder feedback.
Revisions to initial data schema and uses cases are discussed in the future steps section of this report, Section 4. The concept of generic and specific units evolved as part of the Phase II project.

12. Publish specification for data structure.

The MUD development was published in three conference papers (appendixes E, F, G)

5. Summary and Conclusions

The development of the masonry unit database model has been one of the most successful projects within BIM-M. It is evident that purchasers and specifiers of masonry units need more immediate access to masonry unit data. It is clear from the recent BIM-M Symposium in St. Louis that our stakeholders are eager for unified information regarding the geometry and properties of masonry units. We saw presentations from R+D Masonry, CTC, Tradesmen's and CADBlox – all of which demonstrated software where the geometry of masonry units was created and manipulated in an ad-hoc way. The workflows and software exhibited by these stakeholders would be greatly improved by an industry wide masonry unit database. Industry experts Michael Gustafson (Autodesk) and Will Ikerd (Ikerd Associates) identified a masonry unit database and a naming convention as key steps to the further development of BIM-M. The Georgia Tech team looks forward participating in the Phase III MUD project as BIM-M moves into the specification phase.

6. Appendix A: Notes on Masonry Unit Naming

1 April 2015

**Russell Gentry, Shani Sharif, Andres Cavieres
Georgia Institute of Technology**

1. Why are we being asked to “name” masonry units?

To cite two of our external stakeholders Mike Gustafson from Autodesk and Will Ikerd of the BIM FORUM, it is very important that masonry units have machine-readable names. This is critical so that BIM systems and other electronic exchanges can identify the masonry units which are the subject of the exchange. At this point it is not possible to count masonry units in a BIM model, because we don't know what the units are that are in the model. This is a fundamental role of BIM model and so if we cannot count the units, we don't really have masonry BIM. But we should also have a naming convention that makes sense to humans, not just computers. So the names should be human-readable as well.

2. Are we naming the masonry units that we actually sell as company, or are we creating names for generic units?

At this point we are creating names for generic masonry units.

3. But my company does not sell generic masonry units, we sell specific units that have colors, textures, and qualities that are unique to our company.

This is true. What is important is that we develop a library of generic masonry units so that the masonry unit database (MUD) can contain these units along with their names. Your internal product codes (SKUs) will then map to the generic name. And so we could have a generic unit called **CL95.57.204** (which is an example “machine-readable” name where the first part stands for the material type and the second part represents the size of the unit). Any time you see the designation **CL95.57.204** in a BIM model you can say: our company makes over 200 different units that meet that generic description.

4. But there are many masonry units that are similar but are not exactly the same. How do we account for these differences in the naming?

Many companies might make clay unit with cores or frogs that still meets the requirements of the of the standard brick size, the **CL95.57.204** from the example above. Some companies make solid clay units with the standard brick size. If the fact that the unit is solid, has cores, or frogs is important in the BIM model, then this has to be part of the name. Part of the complexity of our naming challenge is determining how specific the “generic” names have to be to support architectural and engineering design, and the initial conversion of a BIM model from “generic” to “specific”. In the CMU world, a tremendous number of units will meet ASTM C90, but the geometry will vary widely for an 8x8x16 stretcher meeting ASTM C90. How specific do we need to be? That is part of our challenge.

5. What do you mean by a BIM model going from “generic” to “specific”?

When the designer creates the BIM model, the specification of the masonry units is probably generic, that is, the architect and engineer will use generic shapes from the masonry unit database to build the

wall families. Later, certain units such as architectural units are converted to specified units to identify the vendor and product selected by the architect and client. Certain units such as gray block will probably remain “generic” within the model as these units are bought out by the mason contractor. He might later choose to update the BIM model so that even the gray block are specified and thus related back to the masonry manufacturer (e.g. for procurement and cost estimation).

6. What is the closest thing in an industry to the think we are trying to create?

You should probably look at the AISC Shapes Database, Version 14.1.¹

7. Does the name of the unit have to tell the entire story?

Absolutely not. The name of the unit only has to be consistent, so that you can enter the Masonry Unit Database to retrieve the relevant properties of the unit. To use the example of structural steel, the name W8x35 tells you very little information in and of itself, but does leads to an entry in the database where a much larger set of information resides. And so for example in structural steel the web thickness and flange dimensions are encoded in the database, but they are not part of the name of the steel section.

8. And so what needs to be in the name of a masonry unit?

As a minimum, the name of the masonry unit should provide its material system and its size. And so for material system we could use, as an example, **CO** for concrete, **CL** for clay, **CS** for cast stone, **DS** for dimension stone etc². The size could be nominal or actual. In the example I used above the size is actual and is the thickness, height and length in millimeters. It really does not make much sense to use fractions in a machine-readable name. We could just as easily work in decimal inches if we prefer. We could also use traditional names like “norman”, “king”, “queen” and “modular” but we will have to be absolutely clear by what we mean if we are going to use these names. But, we have to be aware of the risk that using legacy names may lead to confusion, and the lack of “machine readability” in masonry unit naming.

9. Is that all that is in the name, material and size?

Unfortunately no. There are many other attributes that might need to be part of the name. In the concrete masonry industry, the name must include whether the unit is a sash unit, bond beam, lintel, bullnose etc. all as part of the name. In the clay unit industry it might be important to know which faces of the unit are finished (that is, solid with texture and color). And, it might be important to look at a unit name and know that a given special unit (say a double bullnose) is related to the most common unit (the stretcher) within the same family of units. And so the two names should be quite similar but have some unique aspect, and so for a CMU we might have CO8.8.16-STR and CO8.8.16-OEBB for a typical stretcher and open-end bond beam.

10. Can every masonry unit made be named?

No. The naming convention expected to cover a large percentage of standard masonry unit production. We recognize that for certain units with complex geometry the only portion of the name that makes

¹¹ <http://www.aisc.org/WorkArea/showcontent.aspx?id=6444>

² Following this example you could use TB for thin brick, TL for tile, AV for adhered veneer etc.

sense might be the material system. We should start by identifying all that most commonly produced CMU and clay brick and giving them names. We can then move on to more complex masonry unit types.

11. How is the generic name that we are developing related to the Masonry Unit Database

I'd say it can become some or part of a key into the database, not necessarily the primary one, but that is to be determined as part of the Phase III MUD project.

12. How does the naming convention relate with the Masonry Wall Definition project?

The Masonry Wall Definition project is defining different strategies to represent masonry in BIM applications. Each strategy is related to a phase in the design process. During initial phases, masonry walls can be represented with very little geometric detail, but with a reference to generic masonry types the architects are intending to use. In this case the generic name convention works as starting point in the process. Later on, more detail is added in terms of different unit types, say for corners and lintels, but still at a general level. In final stages specific types, possibly with vendor specification needs to be identified and associated to specific portions of the wall. At any time in the process, there is a link with the Masonry Unit Database for querying purposes.

7. Appendix B: Masonry Unit Model Definition Report 1 (3 March 2014)

**Building Information Modeling for Masonry
Phase II Project**

**Project 1, Masonry Unit Model Definition
Pankow Foundation Grant RGA#03-13**

Report 1

**Design and Construction Workflows Related to the
Selection, Specification, and Procurement of Masonry Units**

delivered to

**Charles Pankow Foundation
in support of the
Building Information Modeling for Masonry Initiative (BIM-M)**

**Georgia Institute of Technology
School of Architecture
Digital Building Laboratory**

**T. Russell Gentry, PI
Charles Eastman, co-PI
Shani Sharif, Graduate Research Assistant
Tyler Witthuhn, Graduate Research Assistant**

**Jeff Elder, Interstate Brick
Project Manager**

3 March 2014

1. Executive Summary

This report represents the first deliverable from the Phase II Building Information Modeling for Masonry (BIM-M) project, focused on developing a data model for masonry units in the clay, concrete and cast stone industries. This document focuses primarily on design, engineering, and construction workflows in which stakeholders require access to information regarding masonry units. The goal of this document is to identify ways in which BIM and allied tools can benefit from electronic forms of data regarding masonry units, and through this process build up the data requirements for the masonry unit database (MUD). Because of the lack of standardization across the masonry industry, and the wide range of masonry units on the market today, the development of the masonry unit database has been identified as a top priority by the masonry industry. The MUD will act as a data repository for masonry design, material procurement, and estimating tasks.

Section 2 of the report provides a brief background on the BIM-M project and its four phases.

Section 3 of the report reviews existing schemes for classifying masonry units. In this context, classification is the act of grouping or organizing objects according to application, material type or size. Classification of units is important in the masonry unit project as existing schemes suggest natural strategies for organizing the masonry unit database. In addition to overall classification schemes for building products as found in OmniClass, the report reviews existing organizing of masonry units by material type, size, and application.

Section 4 of the report introduces the concept of workflows and the BPMN (Business Process Modeling Notation) used in this report. This section describes in general how the workflows are developed, through interactions with stakeholders. This section provides definitions for masonry workflows that vary based on the type of masonry material under consideration, and defines the terms “generic”, “specified” and “custom” masonry to clarify how the workflows will vary based on the masonry units under consideration.

Section 5 of the report presents a general narrative of the AEC (Architecture Engineering Construction) workflow for a typical project that involves masonry and proposes 13 workflows that happen during a project. The text in this section discusses how various stakeholders in the project interact with one another and illustrates their requirements for information regarding masonry units.

Section 6 presents 5 of the 13 workflows in greater detail, with BPMN diagrams for each workflow. These include (1) material selection, (2) architectural design and construction documents, (3) structural analysis and design,, (4) energy analysis, and (5) quantity take-off and cost estimation. The section introduces the idea of an exchange, where the exchange represents a query from the MUD (masonry unit database) or the passing of information from one stakeholder to another. An analysis of the information needed in each of these exchanges becomes the basis for establishing the information required in the MUD.

Section 7 presents an initial structure for the MUD based on an entity-relationship model. The model is still under development at this time and is presented to show the process by which the MUD is being developed. Example geometric attributes for concrete masonry units are presented to show how generic masonry units will be instantiated in the database.

2. Background

In January 2013, the Digital Building Laboratory (DBL) at the Georgia Institute of Technology completed a roadmap to bring Building Information Modeling (BIM) to masonry. This overall project involves industry trade associations and stakeholders from throughout the masonry industry, BIM and other software providers to the AEC industry, and subject matter experts. The roadmap outlines three phases of research and implementation. The current Development Phase (Phase II) focuses on further elucidating the workflows and software requirements for BIM for masonry, and the completion of seminal projects that will underpin the BIM-M software specification.

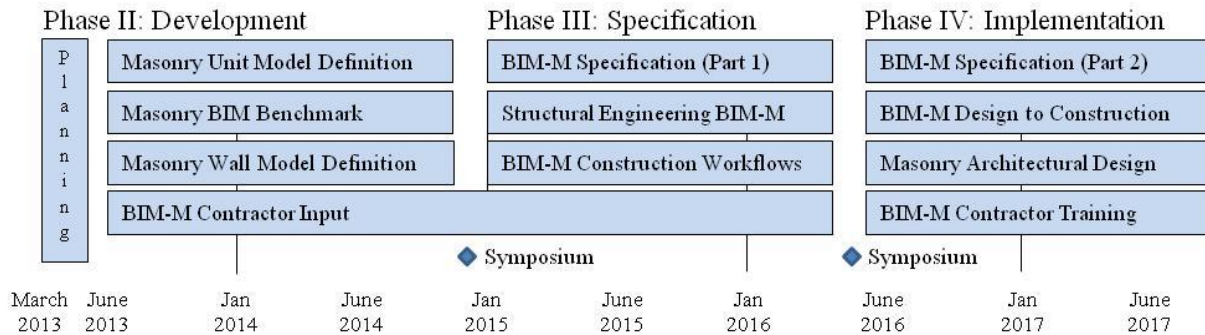

Figure 1. Proposed development and implementation plan from the BIM-M Roadmap. Note that the start and end dates for the Phase II projects have been revised from this original proposal.

The first project in Phase II of the Building Information for Modeling (BIM-M) Initiative is the Masonry Unit Model Definition (MUMD). This first Phase II project focuses on the development and prototyping of a data model for masonry units. In this project, the Georgia Tech team is working with the BIM-M initiative's Material Supply Working Group to develop requirements for digital representation of masonry units. The project is denoted the Masonry Unit Model Definition and the primary deliverable is the proposed structure for and operation of the Masonry Unit Database or MUD. The goal is to develop a data model to capture all of the geometric and non-geometric information needed to select, specify and purchase masonry units. In the future, we envision that the MUD unit will act as a basis for digital product catalogs, web-based product selection applications, masonry e-commerce, cost-estimating and integrated with the BIM applications to be developed later in overall initiative. It is important to note that the MUD is intended to fulfill two distinct but critical roles: first to act as a data repository for the geometric description of the masonry units including its nominal and specific geometry as well as its color and texture and second to capture descriptors needed to facilitate business and engineering processes, such as cost estimating, availability, unit of order, specifications met, etc.

The MUD can be compared to the database of structural steel shapes, created by the American Institute of Steel Construction (AISC) that forms the data foundation for structural steel modeling and fabrication software. The added complexity in the masonry industry is that units are not standardized or classified across industry segments in the way that steel shapes are, and so for example there are many specific unit geometries that may meet a given requirement, and the MUD must be structured in a way so that it can be queried for nominal geometries, and not just specific geometric attributes.

3. Classification of Masonry Units

Once the masonry information required for the MUD is identified, it must be organized in ways that are machine readable by BIM systems. Therefore, a major aspect of this project is the grouping of similar data regarding masonry units. The American Society of Testing and Materials (ASTM) describes classification as: “a systematic arrangement or division of materials, products, systems, or services into groups based on similar characteristics such as origin, composition, properties, or use” [1]. At the highest level of classification, the masonry data must fit within existing classification systems for building projects and products. At this level of classification the system helps define how masonry integrates with other building systems. At a somewhat lower level, the masonry units must be ordered and grouped in a way so that units can be compared with and selected from units with similar attributes. These two levels of classification are discussed in more detail in the text that follows.

Classification of Constructed Facilities and Projects

The classification of construction information began with the development of specification formats such as MasterFormat in the United States, primarily as means to organize project manuals [2]. As these formats promote document management strategies, they do little to facilitate the organization of information in BIM systems. Construction classification systems that evolved more recently, such as OmniClass in North America [3, 4] and Uniclass in the United Kingdom provide organizational structures for projects, products, and assemblies, which can be more closely linked to BIM tools. Much of the BIM product data available today is organized according to OmniClass Table 23 (Building Products) or Uniclass Table L (Products). The extent of the masonry classification in these systems is at a fairly high level, as can be seen in that portion of OmniClass Table 23 that pertains to masonry (Figure 2). As can be seen in Figure 2, the OmniClass Table gives a high-level view of how the masonry information might be organized, but it does not provide detailed information on the geometric or functional aspects of the masonry systems, nor a way to link masonry units to other elements and materials within masonry wall systems.

The European Standard EN 81346 for the modeling of industrial products provides elements of a classification strategy along with some relational semantics of the objects represented in the data structure [5]. According to Ekholm and Haggstrom, the Danish Building Classification system or DBK, is based on the EN 81346 and provides a well-developed structure for organizing building product data for use in BIM [6]. The relational semantics in the DBK are limited to the following:

1. Parts with functional relations, for example: cast stone sill supports window frame;
2. Parts with compositional relations, for example, exterior wall is composed of stretcher and header units in a set pattern such as Flemish bond;
3. Parts with spatial relations, for example, sun screens are adjacent to masonry wall.

Table 23	Products					
OmniClass Number	Level 1 Title	Level 2 Title	Level 3 Title	Level 4 Title	Level 5 Title	Level 6 Title
23-13 21 00		Blocks and Bricks				
23-13 21 11			Concrete Masonry Units			
23-13 21 11 11				Concrete Blocks		
23-13 21 11 13				Exposed Aggregate Concrete Masonry Units		
23-13 21 11 15				Fluted Concrete Masonry Units		
23-13 21 11 17				Interlocking Concrete Masonry Units		
23-13 21 11 19				Molded Face Concrete Masonry Units		
23-13 21 11 21				Prefaced Concrete Masonry Units		
23-13 21 11 23				Preinsulated Concrete Masonry Units		
23-13 21 11 25				Sound Absorbing Concrete Masonry Units		
23-13 21 11 27				Split Face Concrete Masonry Units		
23-13 21 13			Calcium Silicate Masonry Units			
23-13 21 15			Glass Masonry Units			
23-13 21 17			Adobe Masonry Units			
23-13 21 19			Clay Masonry Units			
23-13 21 19 11				Common Bricks		
23-13 21 19 13				Face Bricks		
23-13 21 19 15				Fire Bricks		
23-13 21 19 17				Glazed Bricks		
23-13 21 19 19				Ceramic Glazed Clay Masonry Units		
23-13 21 19 21				Clay Tile		
23-13 21 19 23				Structural Clay Tiles		
23-13 21 19 25				Clay Flue Linings		
23-13 21 19 27				Terra Cotta Units		
23-13 21 21			Masonry Anchorage and Reinforcement			
23-13 21 21 11				Masonry Reinforcing		
23-13 21 21 11 11					Continuous Joint Reinforcing	
23-13 21 21 11 13					Reinforcing Bars	
23-13 21 21 13				Masonry Ties		
23-13 21 21 13 11					Flexible Masonry Ties	
23-13 21 21 13 13					Masonry Veneer Ties	
23-13 21 21 13 15					Rigid Masonry Ties	
23-13 21 21 15				Masonry Anchors		
23-13 21 21 15 11					Masonry Veneer Anchors	
23-13 21 21 15 13					Stone Masonry Anchors	
23-13 21 23			Special Profiles for Masonry			
23-13 21 23 11				Special Masonry Shapes		
23-13 21 23 13				Masonry Sills and Thresholds		
23-13 21 23 15				Masonry Moldings		
23-13 21 23 17				Masonry Copings		
23-13 21 23 19				Masonry Quoins		
23-13 21 23 21				Masonry Cornices		
23-13 21 25			Structural Support for Masonry			
23-13 21 25 11				Lintels		
23-13 21 25 11 11					Lintel Former Units	
23-13 21 25 13				Wall Connectors and Starters		
23-13 21 25 15				Supports for Masonry		
23-13 21 25 15 11					Masonry Angles	
23-13 21 25 15 11 11						Masonry Shelf Angles
23-13 21 25 15 13					Gussets	
23-13 21 27			Ancillary Products for Masonry			
23-13 21 27 11				Embedded Flashing		
23-13 21 27 13				Cavity Closers		
23-13 21 27 15				Cavity Weep and Ventilation Units		
23-13 21 27 15 11					Cavity Weeps	
23-13 21 27 15 13					Cavity Vents	
23-13 21 27 15 15					Cavity Drainage Material	
23-13 21 27 17				Masonry Joint Materials		
23-13 21 27 17 11					Masonry Control Joints	
23-13 21 27 17 13					Masonry Expansion Joints	
23-13 21 27 19				Airbricks		

Figure 2. OmniClass classification for masonry.

Despite the apparent robustness of the DBK system, it is not clear whether a linked classification and compositional description is desired. It may be that a pure classification system for masonry units and their accessories, along with separate compositional description within an Open BIM environment that supports IFCs [7] will provide the best way of hosting and maintaining masonry product data. The focus of the MUMD project is to organize and classifying masonry units and associated materials and products, but without focusing on the larger issues of the composing of masonry units into assemblies. The focus on assemblies will take place in the upcoming Phase II project on masonry walls.

Classification of Masonry Materials at the Detailed Level

OmniClass Table 23 (Figure 2) provides a high-level approach for grouping masonry units. The primary division is by material type. For each unit type, there is a tremendous amount of geometric and non-geometric data associated with the unit. This information is discussed in detail in the sections below, organized by material types.

Concrete Masonry Units

Concrete masonry units (CMUs) are typically manufactured blocks formed out of zero-slump (very low amounts of water) concrete mix. These units are typically nominally 16 inches long and 8 inches high with widths that vary typically between 4 inches and 14 inches. In addition to material type, these nominal dimensions provide the primary means by which units are classified and referred to, but units are typically manufactured at 3/8ths of an inch less than those given. This allows for a typical mortar joint of 3/8ths of an inch to form a 16 by 8 inch section of wall.

Units can be formed as solid units or have hollow cores where rebar, grout, or insulation, or plumbing and electrical chases may be placed. Typical units have 2 cores, but manufacturers produce units with up to 4 cores as well. Outside faces and ends can be manufactured with multiple different textures for a specific feel or use of the unit, and the entire concrete mix can be colored with pigments to deliver a range of colors.

Though the nomenclature for concrete masonry unit types and sizes has not been standardized – there are generally recognized names for units. In the late 1990's, the National Concrete Masonry Association (NCMA) proposed a standard nomenclature and dimensional guidance for masonry units for use across the country – but this draft standard has not been adopted [8]. A current technical note from the NCMA does provide dimensions for the most common units [9]. The NCMA also promotes a standard nomenclature for the surface finish and texture of CMUs, but it is not clear to what extent this nomenclature is used in industry [10].

Architectural Brick

Architectural or facing brick is used in veneer applications or structurally in multi-wythe walls. In common North American practice these bricks are not used in load-bearing applications, though they do carry their own weight or may help stiffen the backup wall section. Typically the bricks are attached by ties to a backup system of CMUs, steel stud, concrete, or in some residential applications wood studs. These ties bring any out of plane forces, such as wind, into the structural element of the wall system.

Brick is classified by size, method of manufacture, color and texture. The Brick Industry Association (BIA) provides information on the most common brick sizes produced in North America, but the major brick suppliers provide many thousands of special brick types [11].

Structural Brick

Structural or hollow brick is made with clay, like architectural brick, but are generally larger so as to have structural capacity in single-wythe applications. Structural bricks often have cores for reinforcing and grout. In

the United States, the Western States Clay Products Association is specifically manufactured for seismic resistance. The association does not publish standard sizes of structural brick.

Cast Stone

Almost all cast stone is custom designed in a collaboration between the architect and cast stone producers for building accent pieces such as lintels, sills, and trim parts. Because the range of parts is quite variable, all pieces are generally made to order and require more complicated design drawings than a standard masonry wall. Almost all cast stone exists in a “custom” masonry workflow. This provides particular challenges for BIM systems, because generic cast stone does not exist, and the instantiation of cast stone in BIM will require a database that is flexible enough to handle complex geometries as well as variations between parts. Some aspects of these custom masonry workflows for cast stone have been developed and documented by Richard Carey, and are described in his U.S. patents (see for example: [12]).

4. Masonry Unit Workflows

In this first report on the MUMD project, a number of workflows involving the typical stakeholders in a masonry design and construction workflow are proposed. The workflows and exchanges described here are restricted to those that require or generate information about masonry units. Future BIM-M projects, such as the BIM-M Benchmark project, will generate a broader set of workflows for masonry design and construction information. In terms of the original Phase II MUMD proposal to the Pankow Foundation, the delivery of these workflows in this report represent the completion of Tasks 1 and 2 in the project. The workflows are organized by project phase, as described in OmniClass, 2006, Table 31, Phases and proceed roughly along a generic timeline associated with a masonry design and construction project¹.

Because this document focuses on the flows of information regarding masonry units, three categories of masonry units are considered:

1. Generic masonry units are those that are described in the design documents by nominal geometry and key attributes (e.g., strength) but for which there are few or no limitations to product substitution. The standard gray CMU is a generic masonry unit.
2. Specified masonry units are those units that are specified in the design documents by brand, color and type. If the contractor wishes to substitute for a specified masonry unit, a formal change order and acceptance from the design team would typically be required. Specified masonry includes most face brick and architectural CMU.
3. Custom masonry units are those units that are produced specifically for the job and which typically require a shop drawing or other submittal that is approved by the design team. Custom masonry units include most cast and cut stone.

Because these terms have unique meanings in this context, they are underlined as a reminder in this text.

It is important to note that these workflows as presented here are schematic in nature, in that the exact nature and mode of the information transfer associated with each transaction is not considered. This document represents a first step, and the intent here is that the workflows are general enough to be

¹ The OmniClass phase tables provide a detailed list of design and construction activities (See: www.omniclass.org). Table 31 is currently undergoing revision so the 2006 phase attributions are used here. The attribution of a given masonry design or construction process to a specific OmniClass phase is somewhat arbitrary. Where possible, we have selected phases that have a commonly understood meaning in the design and construction community. For a general description of how the design and construction process progresses, see the Architect’s Handbook of Professional Practice, Section 10.5 13. *The Architect’s Handbook of Professional Practice, 15th Edition*. 15th ed. 2013: American Institute of Architects..

understood by the BIM-M stakeholder groups, who will be reviewing and commenting on these workflows (which will subsequently be updated by the Georgia Tech team based on stakeholder feedback). In addition, the publication of these workflows will not lead immediately to a description of the exchanges between automated systems, such as the current project at Georgia Tech related to precast concrete [14, 15]. Rather the workflows are being used as virtual experiments through which we establish the requirements for and, in the future, test the completeness of the masonry unit data model.

A critical review of this document by the Architectural, Structural and Materials working group within BIM-M is a key component of moving ahead with our work. Where stakeholders disagree with the masonry material workflows proposed here, they should identify alternative workflows. In addition, where possible, stakeholders should assist us in identifying detailed data requirements that take place at each of the exchanges captured by the workflows.

Key workflows are documented in Business Process Modeling Notation (BPMN), which provides an industry-standard method of documenting process models and the flow of information². The BPMN diagram is characterized by horizontal “swim lanes”, that indicate actors/stakeholders in a given process, with the overall process proceeding vertically from left to right. Because our use of BPMN is focused on the transfer of information between stakeholders, we use additional swim lanes to locate the data objects (files exchanges, downloads, database queries, etc.) that represent communication between the stakeholders. Ongoing work by the Georgia Tech team will combine workflow models with data models to more completely illustrate the data requirements for the masonry unit database. Initial work towards this goal is described in Section 7. of this report.

5. Workflow Narratives

In the text below, a short description of each phase of a masonry project is provided, along with a narrative describing the general work that is taking place at the various stages of the project within each phase (Figure 3). In Section 6, a detailed description of key workflows and the associated masonry unit data exchanges that take place, along with BPMN diagrams of each workflow, is provided.

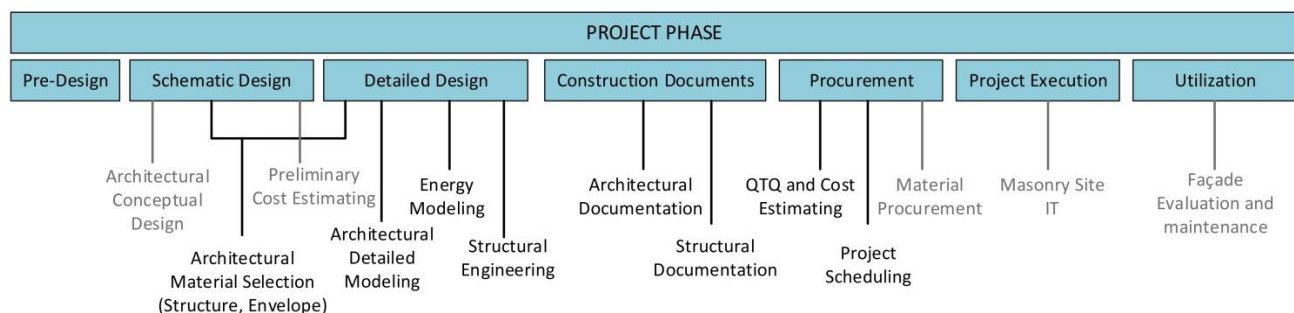

Figure 3. Masonry project timeline with project phases and proposed masonry material workflows.

Pre-Design Phase [OmniClass Phase 31-10 27 00]

The pre-design phase of a project focuses on collecting owner requirements involving a project. A primary architectural activity at this time is establishing the context for the building project and documenting the owner’s requirements for the project. Building programming often takes place at this stage of the process. In

² See www.bpmn.org.

some projects, early building design work that may include materials selection takes place in the pre-design phase, but in general most activities that involve masonry take place later in the project.

Schematic Design Phase [OmniClass Phase 31-10 41 11]

In the schematic design phase, the architect determines the overall form of the building. The building is located on the site and initial ideas about spaces within the building take shape. The building enclosure is not defined at this time, other than rough ideas about fenestration – which may change extensively during this phase to meet energy, daylighting, programmatic, and aesthetic requirements. The digital tools used in this phase are generally not BIM authoring tools, but rather 3-D geometric modelers such as SketchUp, Rhinoceros, and AutoCad.

Architectural Material Selection

At this stage of the project architects may be considering the initial material selection for a building. If so, the focus is mostly on color, texture, and “feel” of the exterior materials – or in a LEED seeking project, the architect will be interested in the geographic source of the masonry materials. In many cases, the building context may require a masonry façade to complement existing building, which may require matching or complementing existing materials. Architects work with material producers and distributors to identify masonry units and mortars, which requires physical specimens in most cases. Through interaction with suppliers and knowledge of what materials are locally available, one or more sample board are provided to the architect from the producer as an initial selection.

Architectural Conceptual Design

In many cases, the material of a building or even its primary structural system is not considered during conceptual design. However, for load-bearing masonry buildings and building with complex masonry forms, the masonry enclosure will definitely be considered as would the approximate location and size of gravity and lateral load bearing elements. Initial structural analyses are likely to be rule-based with little formal structural analysis taking place [16]. For examples of early-stage masonry design from an architectural perspective, see recent papers by Filloramo et al. and Gentry [17, 18]. A conceptual design in this phase may be used to produce 3D renderings of a building with colors and textures applied to the building surface. To accomplish this, an architect would need a wall model complete with mortar and bond patterns. For non-standard masonry shapes, the profile or surface of the masonry units may be required. In terms of the overall BIM-M project, this workflow represents the first interaction between the unit model database and the wall model. At this stage of design, it is not likely that the building model contains any proprietary information regarding masonry units – as only geometry is being considered.

Preliminary Cost Estimate

In the early stages of the project, the design team is typically required to determine whether the project is meeting cost targets established early in the design process. The goal of BIM-enabled cost estimating at this stage of the project is to use the 3D model of the building to identify surface areas of masonry systems [19] and to apply square-foot costs to the areas. The identification of custom masonry features (for example, cut stone and cast stone) and an ability to link to the manufacturers of these products for cost-estimating is a potential use of the MUD, but it is unclear as this stage as to whether and how cost information is going to be included in the database.

Detailed Design Phase [OmniClass Phase 31-20 20 11]

In the detailed design phase, a wide range of design decisions are being considered, tested, examined, reconsidered and finalized. The architect and engineering consultants transition away from 3D wireframe

modeling and document the building in BIM authoring platforms (e.g., Revit, Bentley BIM, Vectorworks, Digital Project) or in traditional 2D CAD drawings. Feedback from structural and energy analyses are integrated into the architectural design. Wall thicknesses are established.

Architectural Modeling

In the architectural modeling stage, the building floor plans and elevations are established. The exact location of wall and door openings, and the aesthetic aspect of the façade treatment of these openings is determined. The architectural treatment of building corners, parapets, and transitions from non-masonry to masonry façade elements are finalized. Masonry units such as brick veneers, cast stone, and architectural CMU, that have architectural implications, are selected by size, type, color, and manufacturer. Other non-visible masonry is considered in terms of its thickness and module. The aesthetic selection of units may require an update of masonry material selections that took place in the pre-design phase. Wall thicknesses in BIM models are adjusted to match with wall systems composed of these masonry units, but details of walls are likely not produced at this time.

Energy Modeling

In the energy modeling stage, architects collaborate with energy modelers, LEED consultants, and mechanical engineers to establish the predicted energy performance of the building. The energy models are used to establish conformance with state energy codes (typically based on a version of ASHRAE 90.1 [20]) and to determine the potential LEED points possible from the proposed design [21]. Aggregated thermal properties of wall systems such as R-values, thermal mass, infiltration coefficients and albedo are required to complete these analyses. The properties required for energy modeling are generally wall-system properties and not masonry unit properties, but the required properties can be determined from individual material layer properties in a wall using Therm or other software [22].

Structural Modeling

In terms of masonry units, the structural engineer is primarily concerned with the geometric properties of the units along with strength, weight, level of grouting and level of reinforcement in a given wall system. The wall properties relate directly back to the geometry and type of unit being used. Like the energy modeler, the structural engineer is using aggregated properties of the wall, and not specific properties of the masonry units themselves, but the aggregate properties are established based on the properties of the units, mortar, grout and reinforcement. The structural engineer assesses the efficacy of the gravity and lateral load systems and iterates with the architect to finalize on a system solution. This may involve changing the strength, type or size of masonry units and the global reconfiguration of load-bearing walls.

Construction Documents Phase [OmniClass 31-25 10 00]

In the construction documents phase, the design professionals create the models, drawings, details and specifications that are provided to the construction team. This phase has conventionally been referred to as the “contract documents” phase by design professionals as it fulfilled the contractual deliverables in a typical design-bid-build delivery process. In this phase, the models and drawings are coordinated and discrepancies between architectural, structural and mechanical documents are identified and resolved. BIM models are refined and attribute data is attached to identify the specified materials used in building elements. BIM models are brought to Level 300 per AIA and BIM Forum provisions [23, 24]. Wall sections and details that are not part of the BIM models are generated to show design intent. Finish schedules (architectural) and wall schedules (structural) are produced. Specifications that identify the exact type of masonry materials are generated.

Architectural Construction Documents

The architectural construction documents stage entails the final specification of masonry materials and the coordination of frequently non-linked representations of masonry in the BIM models, 2D details, schedules, and specifications. Vertical and horizontal sections are generated to show how masonry interfaces with door and window jambs, headers, sills, and parapet elements. In most cases, it is unlikely that the BIM model contains enough detailed information to portray these details. Often, standard details are maintained within the architectural practice, and are based on representative details provided by BIA, IMI, NCMA or others. Finish schedules including masonry may be generated from the BIM model.

Structural Construction Documents

Structural construction documents involve the detailing and specification of structural masonry. This can include gravity load bearing elements, lateral load resisting systems, and veneer back-up systems. For structural masonry systems, the provision of accessories compatible with units, or special masonry units such as bond beams or precast lintels takes place as construction documents are assembled. This provisioning may make take place in the form of schedules, in the specifications, or as 2D details associated with the BIM models, plans and wall elevations.

Procurement Phase [OmniClass 31-30 00 00]

The procurement phase represents the first activity with primary responsibility from the construction team, as opposed to the design team. In a traditional design-bid-build process, the procurement phase would start during the bid process and continue through construction.

Quantity Takeoff (QTO) and Cost Estimating

In this stage the mason contractor (or perhaps the general contractor) reviews the building models (sometimes) or the plans and specifications (more likely) to determine the total area of the masonry walls and thus establish the unit count for the masonry units on the project. In current practice, mason contractors use in-house spreadsheets, specialized software like Tradesmens³, or general purpose cost-estimating software to establish the cost and quantity of masonry units. At this stage of the process, the mason contractor may negotiate with local masonry supplies for both manufacturer-specified masonry units (e.g., veneer face brick) as well as generic masonry (standard gray CMU) or, he may rely on historical data for material pricing.

Masonry Project Scheduling

For clarity, the term “project scheduling” as used here is the generation of information by contractors and sub-contractors and coordination between them required to create and update the project schedule. Project scheduling does not include the execution of activities on the schedule. Overall project scheduling is a responsibility of the general contractor, but mason contractors both contribute to the overall project schedule as well as manage their own more detailed schedule. In terms of masonry units, the project schedule involves the predicting of masonry production and the subsequent need for materials to flow to jobsite.

Material Procurement

Masonry material procurement involves a wide range of activities that includes elements of the previous two stages (QTO/Cost Estimating and Project Scheduling) and many interactions with masonry unit data. In the context of masonry units, procurement involves the following activities:

- purchase of masonry units

³ See www.tradesmans.com.

- delivery of masonry units from the manufacturer or supplier (for clarity, the act of causing a shipment of masonry units to be trucked to the jobsite is considered procurement and is thus an ongoing procurement activity that continues into the Project Execution Phase)
- delivery of ancillary materials linked to the arrival and installation of the units (mortar, reinforcement, accessories, grout)
- verification of specified or custom masonry units as required by the design team, which can include product submittals, shop drawings, or mock-ups

Project Execution Phase [OmniClass Phase 31-40 00 00]

In the project execution phase teams of masons under the direction of the mason contractor bring a wide range of materials together on the jobsite and assemble the masonry walls. Though there are numerous masonry-related activities on the jobsite, not many of these activities require data about masonry units, that is, a transaction with the MUD.

Masonry Site Information Technology

The long-term goal of a BIM-enabled construction site is to provide information to masonry crews and this activity is described generically as masonry site information technology. In the current state, there is little need for information about the masonry units themselves on the jobsite, but in the future it may be that the MUD can provide installation guidelines or other information directly to mason crews.

Utilization Phase [OmniClass Phase 31-50 00 00]

In the utilization phase, the building is occupied and under use. From time to time, masonry facades must be cleaned, tuck-pointed, and in historic structures, rehabilitated and restored.

Façade Evaluation and Maintenance

Façade evaluation and maintenance involves a number of activities requiring information about masonry units, which may be facilitated by access to the masonry unit database. These include the selection of cleaning regimes or other treatments such as sealers for a given masonry unit and the identification or best match of existing masonry units by material, shape, color and texture.

6. Workflow Diagrams and Exchanges

In this section key workflow diagrams identifying exchanges of masonry unit information between stakeholders are provided as BPMN (business process modeling notation) diagrams. The overall workflow is shown in Figure 4. Five key workflows are expanded upon in the text and figures that follow. The OmniClass classification of the stakeholders are provided as horizontal swim lanes. The narrative refers to activities in the workflows based on the numbering scheme found in square brackets [X.Y] in the diagrams.

The workflows are provided to illustrate database transactions (queries) that can be made to the masonry unit database and further define the nature of information that must be contained in the MUD. It is important to remind our stakeholders that these workflows are preliminary: they describe our interpretation of workflows based on interviews and meetings with masonry-industry partners. A close review and critique of these postulated workflows will be of tremendous assistance to the Georgia Tech team as the MUMD project continues.

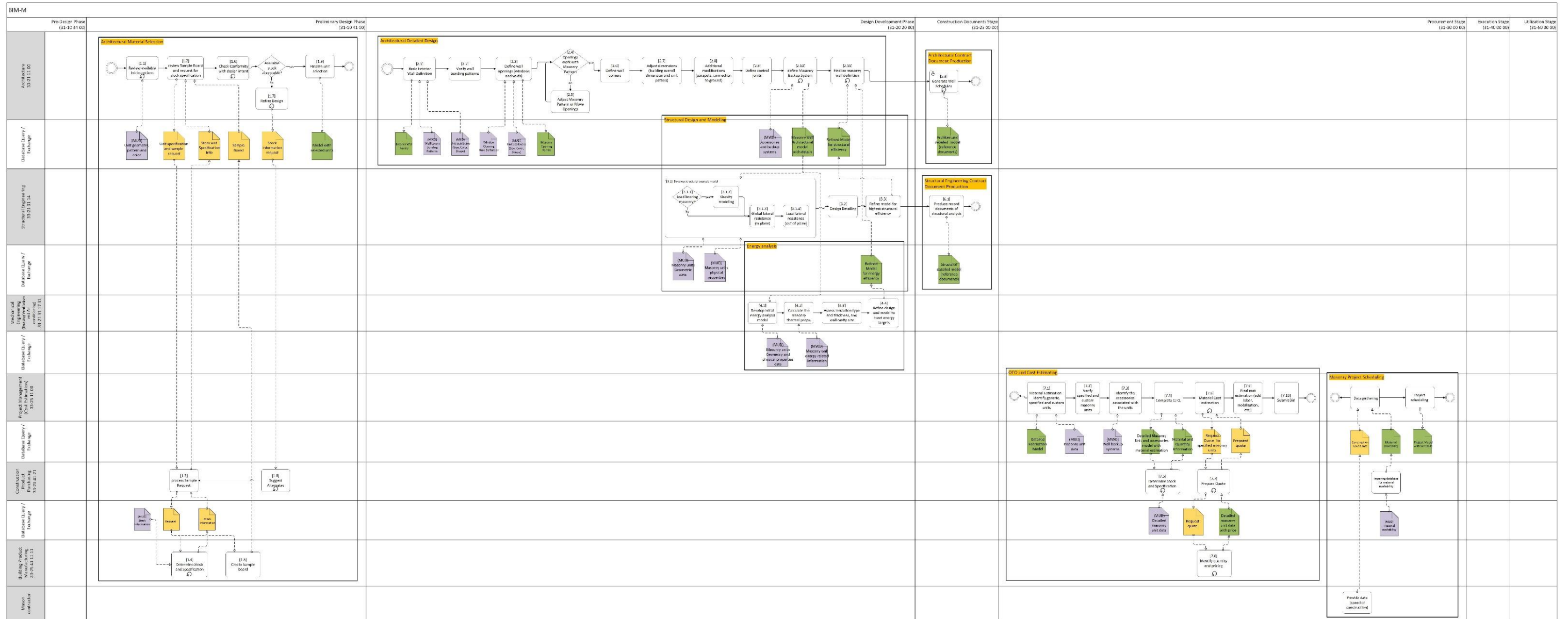

Figure 4. Overall BIM-M workflow from initial design to building maintenance and operation phase.

Architectural Materials Selection

In the architectural materials selection workflow, the architect interfaces with information on the web, with masonry samples contained in the firm’s materials library, with a masonry product representative, and indirectly with a brick producer to receive sample information for the masonry used on a project (Figure 5). The swim lanes in the BPMN diagram represent the architect, the masonry supplier, and the masonry producer. The MUD is depicted as a data store driving the information shown in the producer web sites.

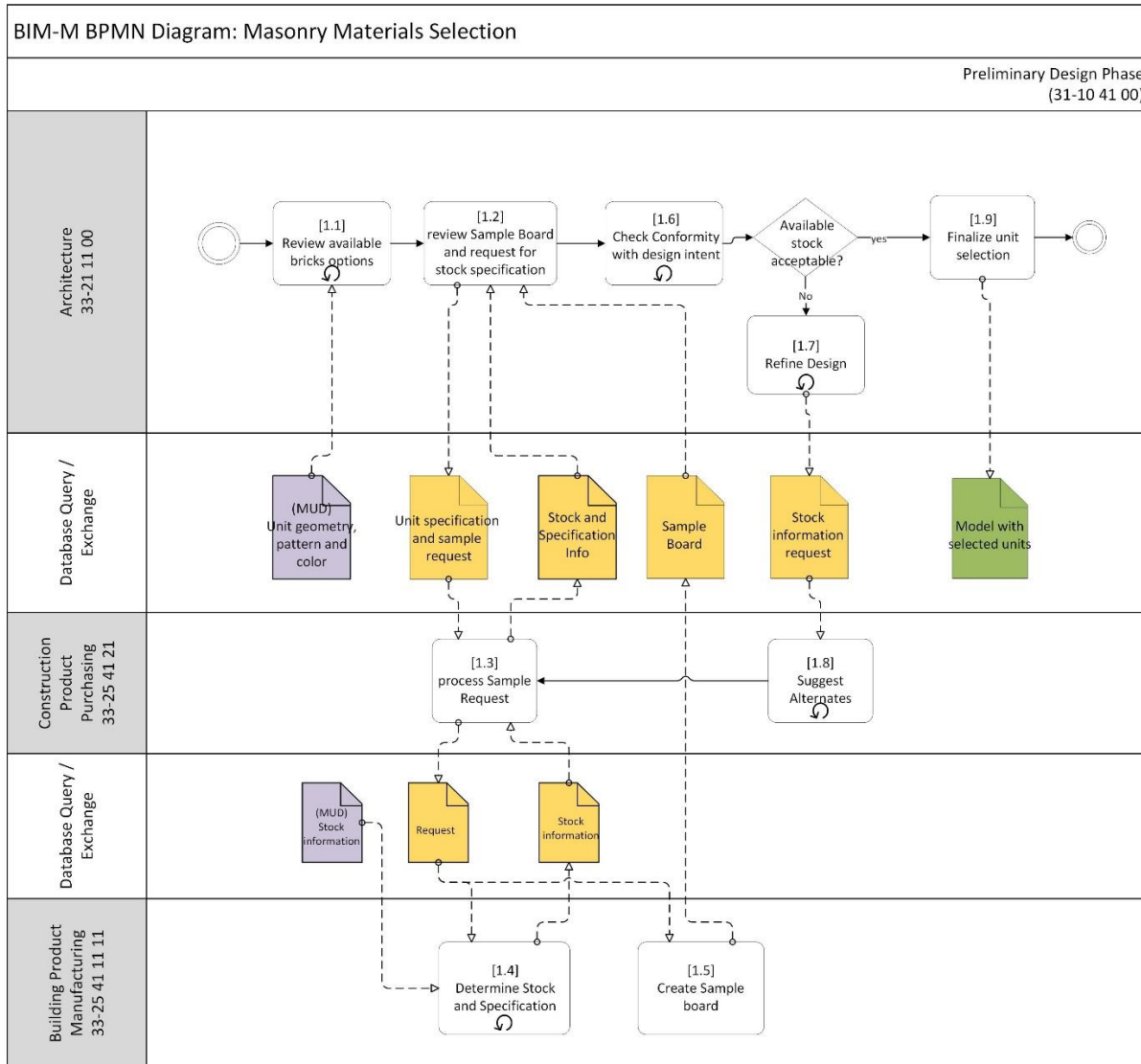

Figure 5. Architectural materials selection workflow in BPMN. Workflow shows architect working with masonry material distributor (and indirectly with producer) to select masonry unit and receive sample board provided by producer.

BPMN Narrative the Architectural Materials Selection Workflow

The architect starts by browsing the web (manufacturer’s web sites) and also by reviewing units and mortar samples on-hand in the firm’s materials library [1.1]. The MUD is used to maintain the information on the website and could also be used to order and track the samples that are housed in the architect’s materials library. Based on these initial review, the architect requests a sample with one or more masonry units with one or more mortar colors [1.2]. The product representative receives the request for the sample board and

checks with the manufacturer to determine if the masonry unit meets the architect's requirements, which could include availability, lead time for production, availability of complementary units, location of production, and price. The manufacturer accesses internal information stored within the database to retrieve product information and verify that the product meets the specification [1.4]. The manufacturer forwards this information back to the product representative who communicates back to the architect. The architect compares this updated information with project requirements and determines if the selected masonry product(s) are acceptable. In many cases, the process may iterate as one or more of the attributes of the masonry are not acceptable to the architect [1.8]. When a product selection has been made, the product representative requests a sample board from the manufacturer, who creates the sample board. When the architect receives the sample board, it is hoped that a masonry sale has been made [1.9].

Architectural Detailed Design and Construction Documents

The next workflow is an illustration of how an architect, building a BIM model, might interact with the masonry unit database (MUD) as shown in Figure 6. Because the process of assembling a building model varies by practice and building type, the workflow is not prescriptive, but illustrative. In addition, the workflow alludes to an additional data model, for masonry walls, denoted the MWD or masonry wall database. This requirements for the masonry wall database will be developed later in BIM-M Phase II. This workflow begins in the Design Development Phase and continues into the Construction Documents phase. The swim lanes represent the architect, data objects from the MUD and data objects from the MWD. The "tasks" are described as queries into the masonry databases, and returned as objects into the BIM model.

BPMN Narrative of the Architectural Detailed Design and Construction Documents Workflow

The architect starts the BIM model by defining the exterior walls of the building. A task is generated to return information about the masonry units and the masonry wall to the BIM model. The colored sheets of paper in the BPMN diagram represent "chunks" of data. In the first task [2.1] the BIM-model definition of the wall family is combined with information from the masonry unit database (MUD) and masonry wall database (MWD). In most real projects there will be more than one such wall definition. This is an automated task, and software such as a "masonry family builder", which receives a request from the BIM authoring tool, extracts data from the MUD on masonry units and data from the MWD on brick patterning and backup systems and returns a Revit wall family ready to be inserted into the BIM model.

Later in the workflow, the architect begins inserting openings into the exterior wall [2.3]. This triggers an additional query to the MWD and MUD whereby BIM objects representing lintels, headers, bond beams, and detailing of cut or custom units around the opening are provided. In terms of software, what is described here could be considered a "masonry window detail" tool. At this stage in the process, the architect is likely to check that the window openings [2.4] fit within the coursing and module of the masonry. If not, then an iterative refinement that will probably include adjusting the size and location of the windows will take place [2.5].

The design will continue to progress and other aspects of wall detailing: parapets, relief angles, curtain wall interfaces, etc. will be added [2.8]. Based on inputs from the structural engineer and energy analyst, the architect will refine the through-the-thickness wall definition including the addition of details regarding the backup system (CMU backup or steel stud size and gage, insulation thickness, air barrier, etc.) [2.10]. Finally, as the project transitions to the Construction Documents Phase, final details, specifications, and schedules will be generated, requiring yet another query into the MUD and MWD [5.1].

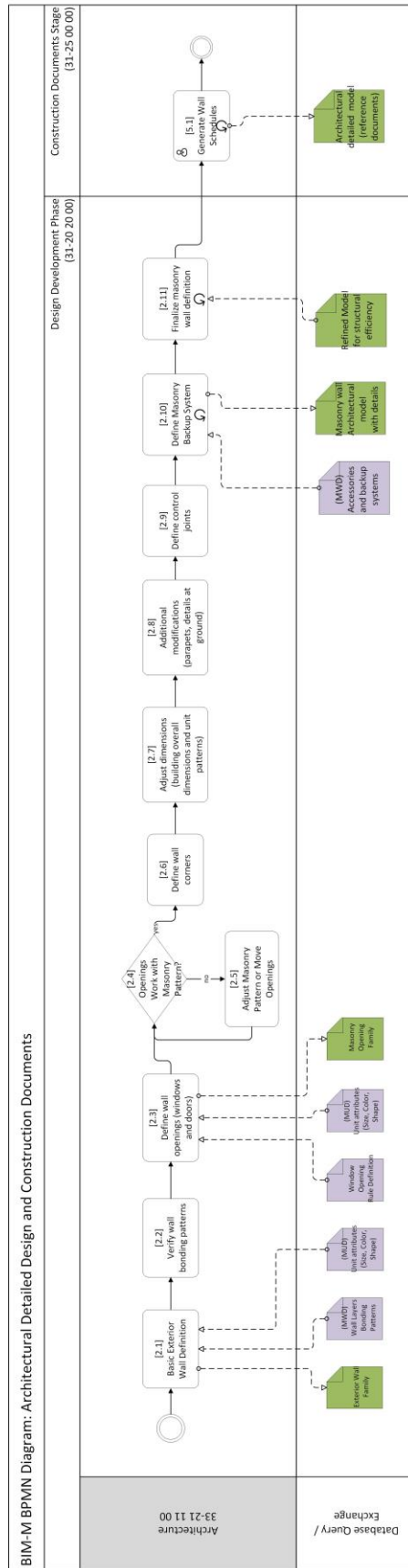

Figure 6. Architectural detailed design and construction documents workflow.

Structural Engineering Analysis and Construction Documents

The structural engineering and construction documents workflow is shown in Figure 7. As in the previous workflow, this process begins in the design development phase and continues through the construction documents phase. At the start, the structural engineer receives BIM model data from the architect. Information on material properties and unit data are retrieved from the MUD and are combined as part of the structural analysis procedure.

BPMN Narrative of the Structural Engineering Workflow

The process begins as the architect has refined the design for the masonry walls (locations and types), see activities 2.10 and 2.11. At this stage the BIM model is likely to contain sufficient information to effect the first transfer of wall geometry from the architectural model to the structural model. The structural engineer will develop the structural analysis model [3.1] depending on the role that the masonry walls play in the project. For a full bearing-wall building, the walls will take gravity, in-plane lateral and out-of-plane lateral forces. Other less complex analyses may be used for hybrid systems or non load-bearing walls. Once the analysis is complete, the masonry walls can be designed – and initial details established [3.2]. These details can be checked against architectural intent, and may require a refinement and redesign of the structural walls [3.3]. As the project progresses into the construction documents phase, full coordination between the architectural and structural models is achieved and the structural plans and details are produced [6.1].

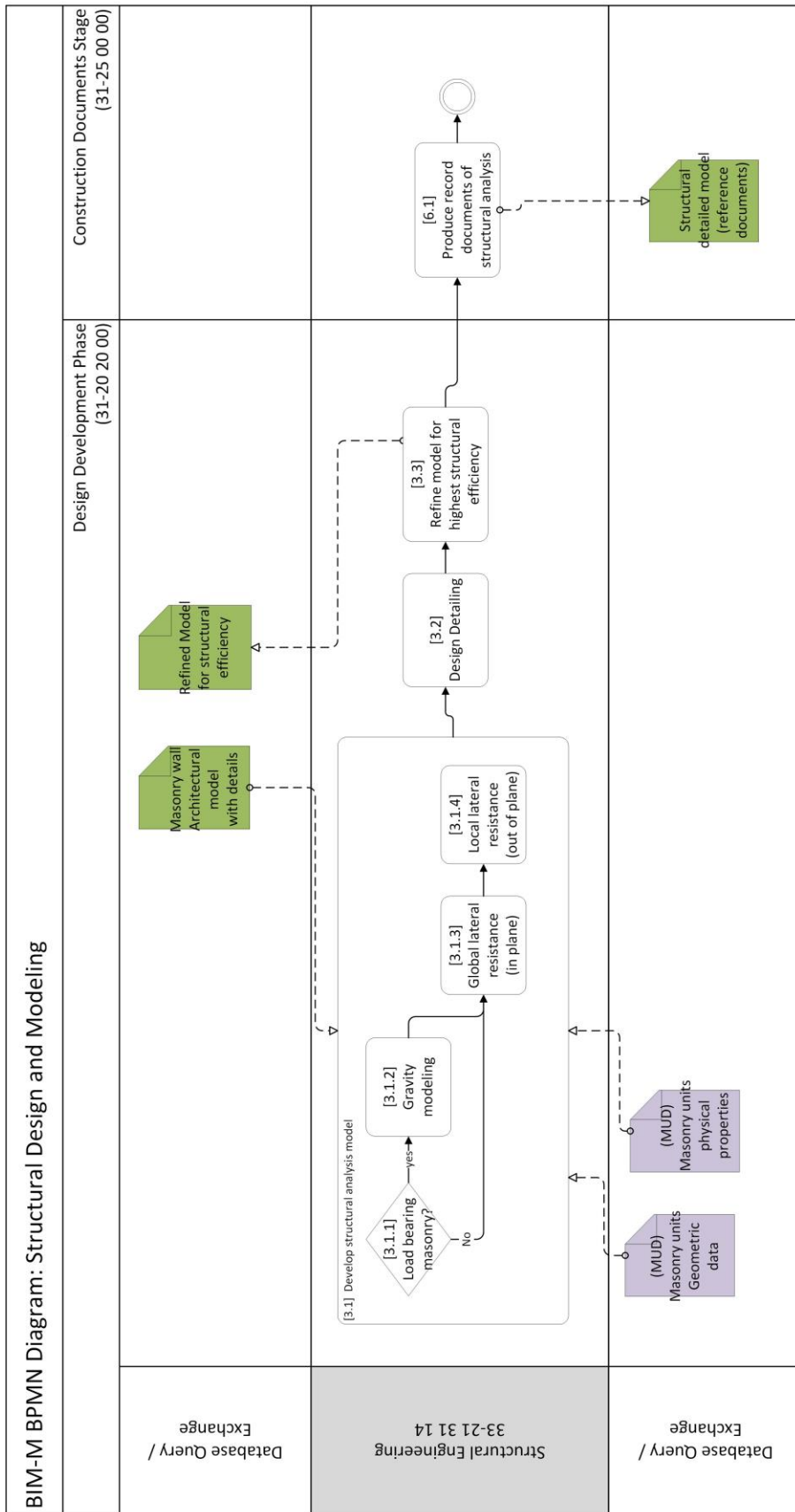

Figure7. Structural engineering analysis and construction documents workflow.

Energy Modeling and Analysis

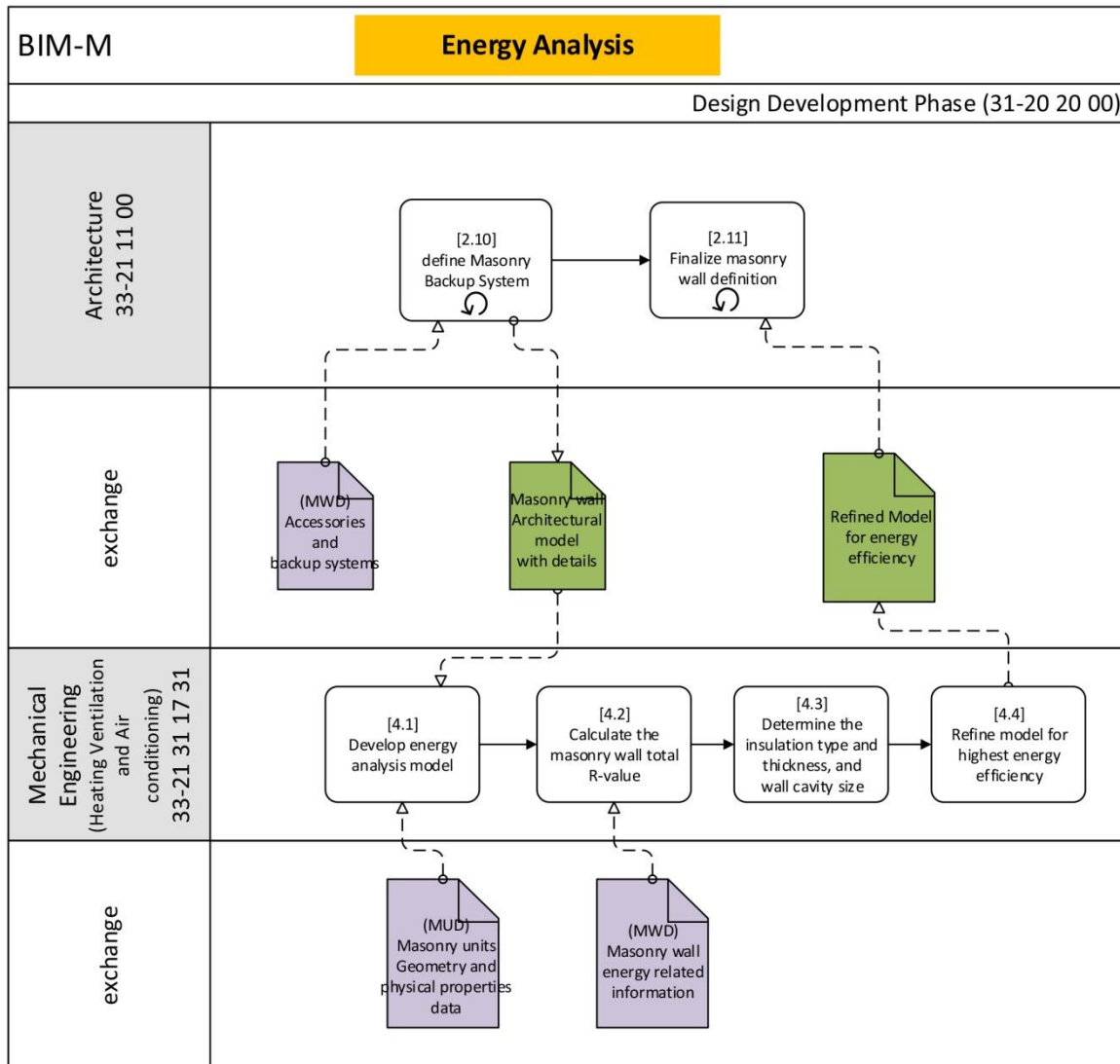

Figure 8. Energy analysis workflow.

Quantity Take-Off and Cost Estimation

A typical waste of BIM data in construction projects is the inability of sub-contractors to use building models to drive quantity take-off and cost estimating. In the masonry construction industry, the industry splits itself almost equally between two workflows. About half of the masonry contractors use an in-house proprietary process based on analyzing the printed drawings and specifications (2D) and entering this information into a spreadsheet for quantity and cost estimation. The other half of the industry uses Tradesmen's software which is a dedicated cost estimation tool for masonry that maintains an internal historical pricing structure for the contractor and which also builds a graphical 3D model of the masonry walls as the walls on the project are identified. In general, the use of Tradesmen's is also based on a manual analysis of 2D drawings and specifications, but does result in the reconstruction of a 3D model that is useful for masonry scheduling and project control, in addition to cost estimating.

The QTO and Cost Estimation workflow described here proposes a view of how the mason contractor will interact with BIM models and the masonry unit database in the future. In the current state, the mason contractor deals with local distributors of masonry units or in some cases directly through the masonry producer. The workflow illustrated here is applicable to generic and specified masonry units. A more detailed workflow, with additional exchanges between the mason contractor, architect, and mason supplier, must be generated to facilitate custom masonry workflows.

BPMN Narrative of the QTO and Cost Estimation Workflow

At the start of a BIM-enabled process for quantity take-off and cost-estimating, the mason contractor initiates a task that queries the BIM model for masonry units (in terms of areas and or number of units, depending on the nature and quality of the building model) (see Figure 5). This task also confers with the masonry unit database to identify generic and specified units that are contained within the BIM model and contain a “match” with units found in the MUD. Finally, this initial task can be configured to return the accessories associated with the units, so that these can be captured as part of this initial data transfer. This first task is quite complicated, and is considered in BPMN terms to be a “collapsed sub process” that will require further refinement once the overall workflow is validated by our mason contractor stakeholders.

Once this initial query is complete, the data object produced is passed to the next step. In this case two options to the workflow are represented – either the data is passed to a spreadsheet, with a prescribed format [3.2] or it is passed to Tradesman software [3.3]. At this point the masonry estimator will validate the masonry materials generated from the BIM model query and complete missing information by contacting product representatives [3.4] ⁴. In some cases the product representative may have to go the producer to validate the selected products [3.5 and 3.6]. In task [3.7] the estimator finishes the take-off by completing information that did not come forward from the query of the building model.

It is now assumed that through a combination of automated processes, along with manual validation, the mason contractor is ready to price the masonry, For specified masonry it is likely that contact with the suppliers and/or producers is required [3.9 and 3.10]. In some cases, these pricing inquiries may be automated or partially automated, and ongoing work in the structural steel industry is leading to automated exchanges for the pricing of fabricated structural steel. For generic masonry, the estimator may use historical pricing – without the need for manufacturers quotes.

⁴ We recognize that no automated take-off process is complete, and that a number of walls may appear in the spreadsheet as “unspecified” because the masonry units selected do not appear in the MUD, or perhaps because of lack of attribute data in the building model.

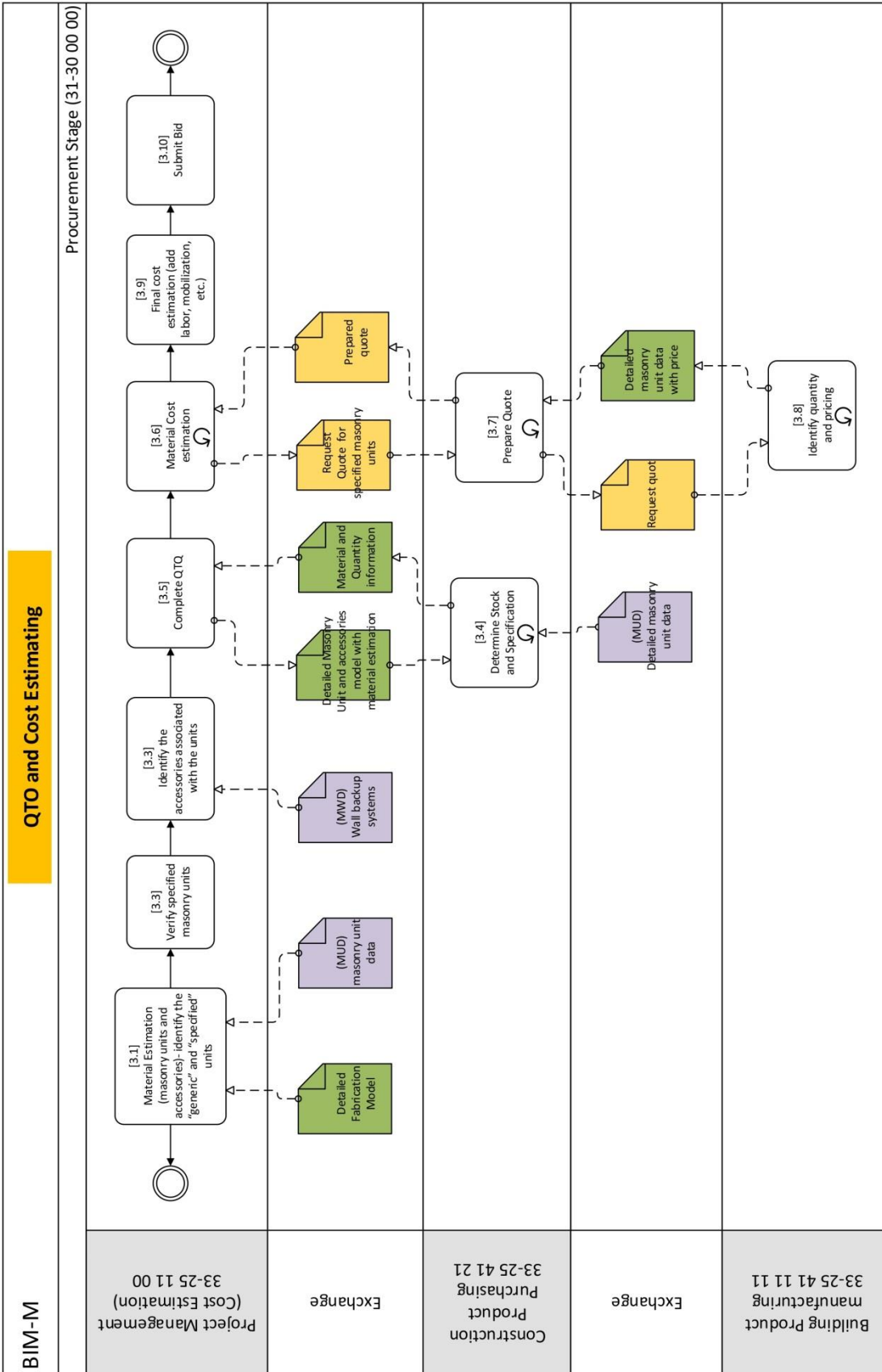

Figure 9. Quantity take-off and cost estimating workflow.

In step [3.11] the estimator inputs unit pricing for the masonry and adds other materials tied to unit quantities accessories into the pricing model. After adding labor costs, overhead, profit and contingencies, the masonry bid package is complete and a bid can be submitted [3.12]. We recognize that the preparation of a bid is iterative, and that the linear process depicted in Figure 5 is over-simplified. In the next part of the MUMD project, we will be reviewing this workflow with mason contractors, and updating the it based on their feedback.

7. Initial Entity / Relationship Model for the MUD

Once the workflows associated with masonry design, engineering, and construction are established, the data needed for each of these exchanges is modeled. In this section of the report we present an initial view of the data model. We have included the attributes provided by the Masonry Supply Working Group (MSWG) during their data-gathering process. At this time, the data model is most complete for unit data regarding geometry, but less complete in its representation of color, texture and other aesthetic attributes. The difficulty with representing these attributes relates back to prior discussion about the classification of colors and textures and is part of our ongoing work. Our initial focus on geometry has been on concrete masonry units, and is taken from an early effort by the NCMA to develop standard sizes and nomenclature for masonry units [8] along with input from the MSWG.

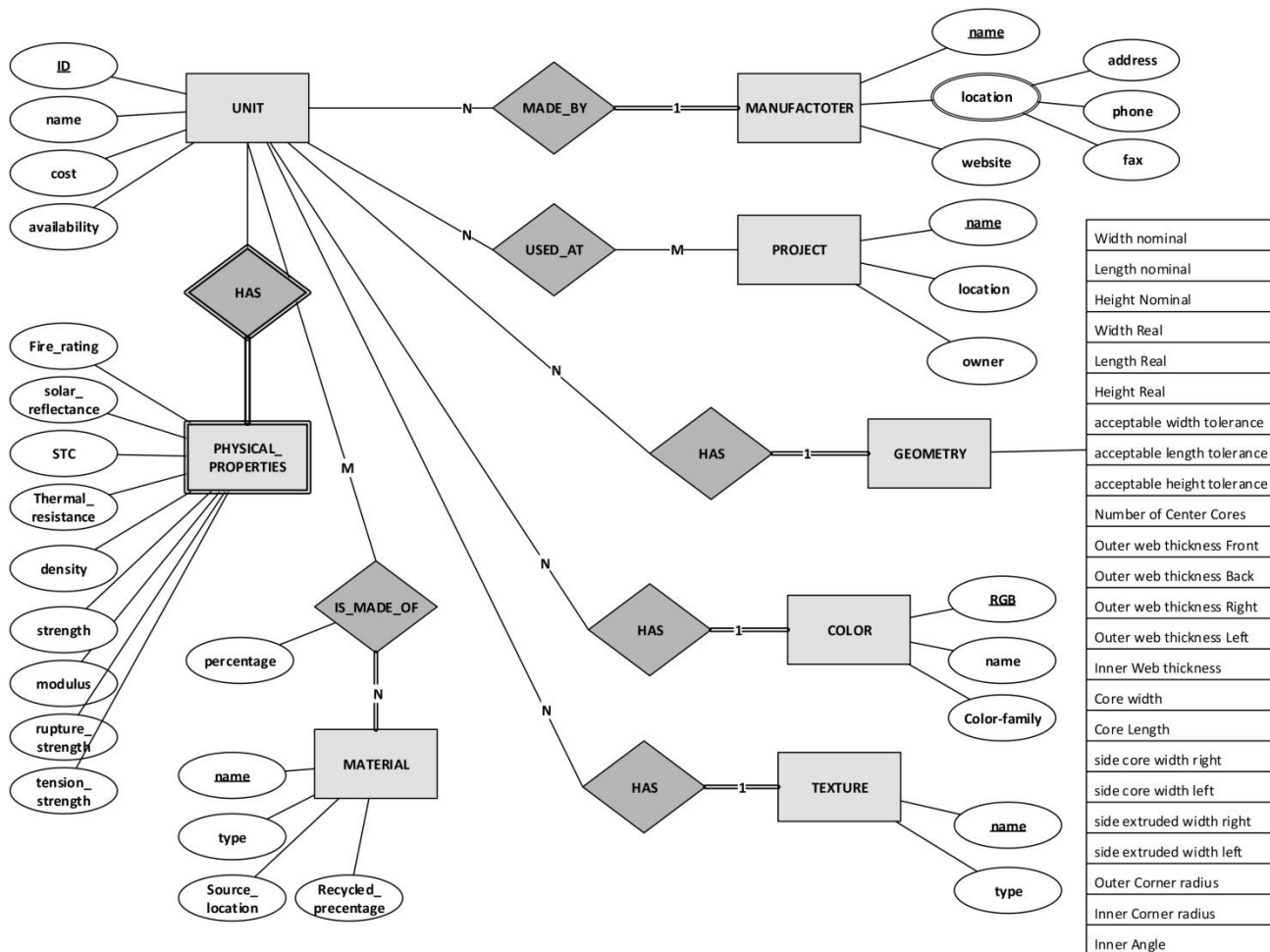

Figure 10. Masonry Unit Entity Relationship (ER) Model, for CMU units

The data model is different from but complements the business process data embodied in the workflows, as data appears as unstructured “lumps” in BPMN notation. And so, to represent the data, an entity-relationship (ER) diagram is used [25]. This ER diagram has the ability to represent the organization of the semantic information regarding the masonry units, based on the requirements of the stakeholders as well as the data exchange requirements of BIM software applications. A relational database structure can be generated once the ER diagram is complete. The main data requirement for masonry unit database (MUD) are the geometric description of the masonry unit (nominal and specific geometry), color, and texture, as well the descriptors needed to facilitate business and engineering processes, such as cost estimating, availability, unit of order, and specifications. In addition, the proposed ER diagram for MUD provides the structure needed for storing, accessing and updating the data during the course of product development to utilization cycle. The proposed ER model for MUD is represented by ER diagram, the special diagrammatic notation associated with the ER models.

The initial ER diagram is shown in Figure 10. Because many of the attributes of the masonry units relate to geometry, some examples of these geometric attributes are shown in Figure 11.

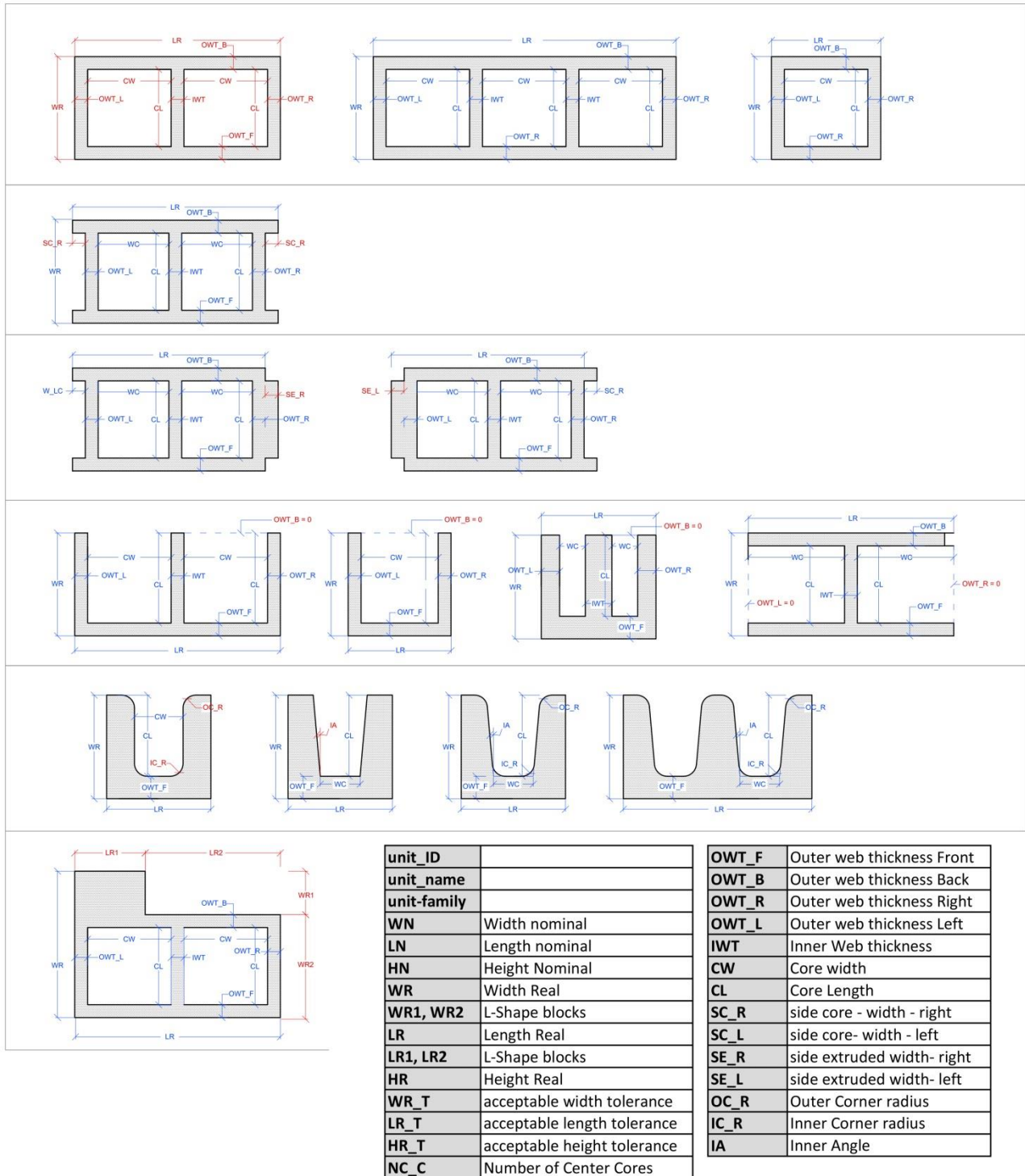

Figure 11. Example attributes for geometric entities (CMU units) in the Masonry Unit Database.

8. Summary and Next Steps

In this first report on the MUMD project, a number of workflows involving the typical stakeholders in a masonry design and construction process have been proposed. The workflows and exchanges described here are restricted to those that require or generate information about masonry units. All of the identified

workflows have been described in narrative form, and five key workflows have been detailed as process models in Business Process Modeling Notation (BPMN). The delivery of these workflows in this report represent the completion of Tasks 1 and 2 in the MUMD project.

In the next few months, BIM-M stakeholder groups will be reviewing and commenting on these workflows, which will subsequently be updated by the Georgia Tech team based on this stakeholder feedback. A critical review of this document by the Architectural, Structural and Materials working group within BIM-M is a key component of moving ahead with our work. Where stakeholders disagree with the masonry material workflows proposed here, they should identify alternative workflows. In addition, where possible, stakeholders should assist us by identifying detailed data requirements that take place at each of the exchanges captured by the workflows.

The entity-relationship diagrams presented here represent the format for the masonry unit database. Masonry unit suppliers should review these diagrams carefully to assess the information we have modeled to date, and to identify areas where additional data needs to be included in the database.

9. References

1. *Form and Style for ASTM Standards*, 2013, ASTM: West Conshohocken, PA USA. p. 74.
2. Gulledge III, C.E., L.E. Beougher, M.J. King, R.P. Dean, D.J. Hall, N.M. Giglio, G.W. Bevier, and P. Steinberg, *MasterFormat 2004 Edition, 2007 Implementation Assessment*, 2007, CSI / CSC. p. 27.
3. Knopp-Trendafilova, A., J. Suomi, and M. Tauriainen. *Link between a structural model of buildings and classification systems in construction*. in *1st International Conference on Improving Construction and Use through Integrated Design Solutions, CIB IDS 2009, June 10, 2009 - June 12, 2009*. 2009. Espoo, Finland: Technical Research Center of Finland.
4. Davis, D., *Updating OmniClass*, in *The Construction Specifier* 2010. p. 14-15.
5. CENELEC, *DS/EN 81346, Industrial systems, installations and equipment and industrial products – Structuring principles and reference designations – Part 1: Basic rules*, 2009: Brussels and København, Denmark.
6. Ekholm, A. and L. Haggstrom. *Building Classification for BIM - Reconsidering the Framework*. in *Computer, Knowledge, Building: CIB W78-W102 2011: CIB International Conference 2011*. Sophia Antipolis, France: CIB.
7. Gokce, K.U., H.U. Gokce, and R.J. Scherer. *IFC view for product catalogues in the construction management domain*. in *European Conference on Product and Process Modelling, ECPPM 2012, July 25, 2012 - July 27, 2012*. 2012. Reykjavik, Iceland: CRC Press.
8. NCMA, *Concrete Masonry Shapes and sizes Manual*, 1997, National Concrete Masonry Association.
9. NCMA, *Typical Sizes and Shapes of Concrete Masonry Units*, 2002, National Concrete Masonry Association. p. 4.
10. NCMA, *TEK 2-3A: Architectural Concrete Masonry Units*, 2001, National Concrete Masonry Association.
11. BIA, *Dimensioning and Estimating Brick Masonry*, in *Technical Notes on Brick Construction* 2009, Brick Industry Association. p. 11.
12. Carey, R., *Method and apparatus for interactively designing custom decorative stonework*, USPTO, Editor 2005: USA.
13. *The Architect's Handbook of Professional Practice, 15th Edition*. 15th ed. 2013: American Institute of Architects.
14. Jeong, Y.S., C.M. Eastman, R. Sacks, and I. Kaner, *Benchmark tests for BIM data exchanges of precast concrete*. *Automation in Construction*, 2009. **18**(4): p. 469-484.
15. Eastman, C., Y. Jeong, R. Sacks, and I. Kaner, *Exchange Model and Exchange Object Concepts for Implementation of National BIM Standards*. *Journal of Computing in Civil Engineering*, 2010. **24**(1): p. 25-34.

16. Gentry, T.R., T. Al-Haddad, A. Cavieres, and L.F. Kahn. *Structural Analysis and Design Of Non-Planar Corbeled Concrete Masonry Walls*. in *11th North American Masonry Conference*. 2011. Minneapolis, Minnesota, USA: The Masonry Society.
17. Filloramo, R., M. Scogin, J. Pindyck, M. Filisky, and D. Biggs. *Brick Beyond Boundaries*. in *11th North American Masonry Conference*. 2011. Minneapolis, Minnesota, USA.
18. Gentry, T.R. *Digital Tools for Masonry Design and Construction*. in *2013 ARCC Spring Research Conference 2013*. Charlotte, NC USA: University of North Carolina, Charlotte.
19. Cheung, F.K.T., J. Rihan, J. Tah, D. Duce, and E. Kurul, *Early stage multi-level cost estimation for schematic BIM models*. *Automation in Construction*, 2012. **27**: p. 67-77.
20. ASHRAE, *ANSI/ASHRAE/IES Standard 90.1-2013 -- Energy Standard for Buildings Except Low-Rise Residential Buildings*, 2013: Atlanta, Georgia, USA.
21. *Advanced Energy Modeling for LEED, Version 1.0*, 2010, USBGC.
22. Charlie, H., K.A. Dariush, U.F. Elizabeth, M. Robin, T.G. Brent, and C.C. Dragan. *THERM 2.0: A Building Component Model for Steady-State Two-Dimensional Heat Transfer*. in *Building Simulation 99, International Building Performance Simulation Association (IBPSA)*. 1999. Kyoto, Japan.
23. BIM_Forum, *Levels of Development Specification for BIM Models*, 2013, BIM Forum.
24. AIA, *AIA E203, Building Information Modeling and Digital Data Exhibit*, 2013, American Institute of Architects.
25. Chen, P.P.S., *The entity-relationship model—toward a unified view of data*. *ACM Transactions on Database Systems (TODS)*, 1976. **1**(1): p. 9-36.

8. Appendix C: Masonry Unit Model Definition Report 2 (13 August 2014)

**Building Information Modeling for Masonry
Phase II Project**

**Project 1, Masonry Unit Model Definition
Pankow Foundation Grant RGA#03-13**

Report 2

Masonry Unit Database

delivered to

**Charles Pankow Foundation
in support of the
Building Information Modeling for Masonry Initiative (BIM-M)**

**Georgia Institute of Technology
School of Architecture
Digital Building Laboratory**

**T. Russell Gentry, PI
Charles Eastman, co-PI
Shani Sharif, Graduate Research Assistant
Tyler Witthuhn, Graduate Research Assistant
Jeff Elder, Interstate Brick
Project Manager**

13 August 2014

1. Executive Summary

This report provides a detailed description of the proposed Masonry Unit Database or MUD, developed by Georgia Tech for the Building Information Modeling for Masonry (BIM-M) Initiative. The content and organization of the database has been derived based on an analysis of the masonry industry from the perspective of major stakeholders in the industry, including masonry suppliers, purchasers, design professionals, contractors, and masons. In addition, the database has been structured to complement existing classification schemes for masonry materials. A detailed description of masonry material workflows and classifications can be found in the first report from this project.¹ A brief description of stakeholders and their requirements for information can be found in Section 3 of this document.

Because the MUD is intended to facilitate the development of new BIM and other software applications for the masonry industry Georgia Tech team has reviewed current applications and their use of masonry data (see Section 5).

Section 6 of the report contains a detailed description of the database, based on the enhanced entity-relationship (EER) model. This model is essentially a graphical view of the schema that will be implemented as a relational database for the first version of the MUD. Future versions of the MUD may be implemented as a cloud database.

This report is an interim deliverable from the Georgia Tech team. At this time, it is critical that we receive feedback as to the organization and content of the proposed MUD. In the fall of 2014 we intend to implement the database with a small selection of masonry units – in an SQL data management system such as MySQL, and we would like for this database demonstration to be as comprehensive as possible. Therefore, a review of the data model by the current BIM-M community, and especially masonry suppliers and software providers, is critical at this time.

2. Background

In January 2013, the Digital Building Laboratory (DBL) at the Georgia Institute of Technology completed a roadmap to bring Building Information Modeling (BIM) to masonry². This overall project involves industry trade associations and stakeholders from throughout the masonry industry, BIM and other software providers to the AEC industry, and subject matter experts. The roadmap outlines three phases of research and implementation. The current Development Phase (Phase II) focuses of further elucidating the workflows and software requirements for BIM for masonry, and the completion of seminal projects that will underpin the BIM-M software specification.

¹ <http://www.bimformasonry.org/pdf/gt-pankow-report-rga-3-13-masonry-unit-workflows-3-march-2014.pdf>

² See: <http://www.bimformasonry.org/pdf/a-roadmap-for-developing-and-deploying-building-information-modeling-bim-for-the-masonry-industry.pdf>

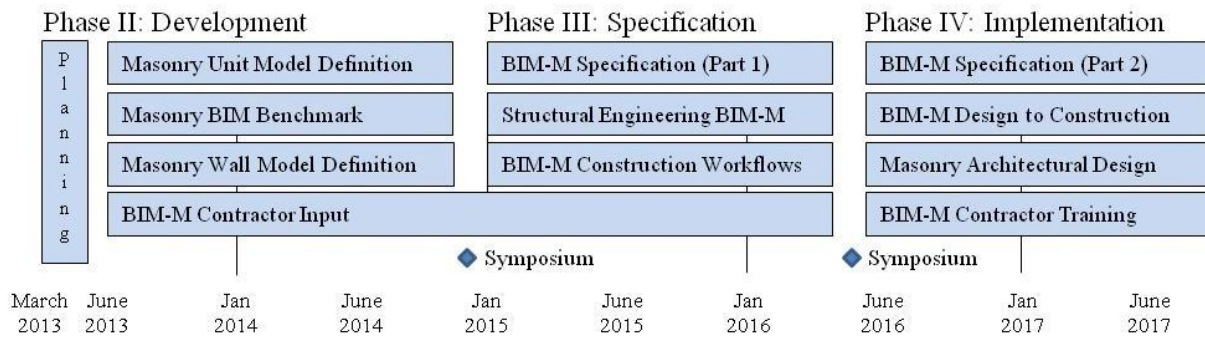

Figure 1. Proposed development and implementation plan from the BIM-M Roadmap.

The first project in Phase II of the Building Information for Modeling (BIM-M) Initiative is the Masonry Unit Model Definition (MUMD). This first Phase II project focuses on the development and prototyping of a data model for masonry units. In this project, the Georgia Tech team is working with the BIM-M initiative’s Material Supply Working Group to develop requirements for digital representation of masonry units. The project is denoted the Masonry Unit Model Definition and the primary deliverable is the proposed structure for and operation of the Masonry Unit Database or MUD. The goal is to develop a data model to capture all of the geometric and non-geometric information needed to select, specify and purchase masonry units. In the future, we envision that the MUD unit will act as a basis for digital product catalogs, web-based product selection applications, masonry e-commerce, cost-estimating and integrated with the BIM applications to be developed later in overall initiative. It is important to note that the MUD is intended to fulfill two distinct but critical roles: (1) to act as a data repository for the geometric description of the masonry units including its nominal and specific geometry as well as its color and texture and (2) to capture descriptors needed to facilitate business and engineering processes, such as cost estimating, availability, unit of order, specifications met, etc. At this time, the first role is the primary focus of MUD development, and business processes must be put in place in order to establish the data required to fully support the second role.

The MUD can be compared to the database of structural steel shapes, created by the American Institute of Steel Construction (AISC) that forms the data foundation for structural steel modeling and fabrication software. The added complexity in the masonry industry is that units are not standardized or classified across industry segments in the way that steel shapes are, and so for example there are many specific unit geometries that may meet a given requirement, and the MUD must be structured in a way so that it can be queried for nominal geometries, and not just specific geometric attributes.

3. Stakeholders

One means to assess the information requirements for the MUD is to characterize the stakeholders in the masonry design, procurement and construction process and to relate these stakeholders to their information requirements. These information requirements are tied to their details regarding their workflows, and these workflows have been described in detail in our previous report¹. An overall view of stakeholders and their access to the MUD is provided in Figure 2. In the text below, we briefly describe the stakeholders and their relationship to the data stored in the MUD.

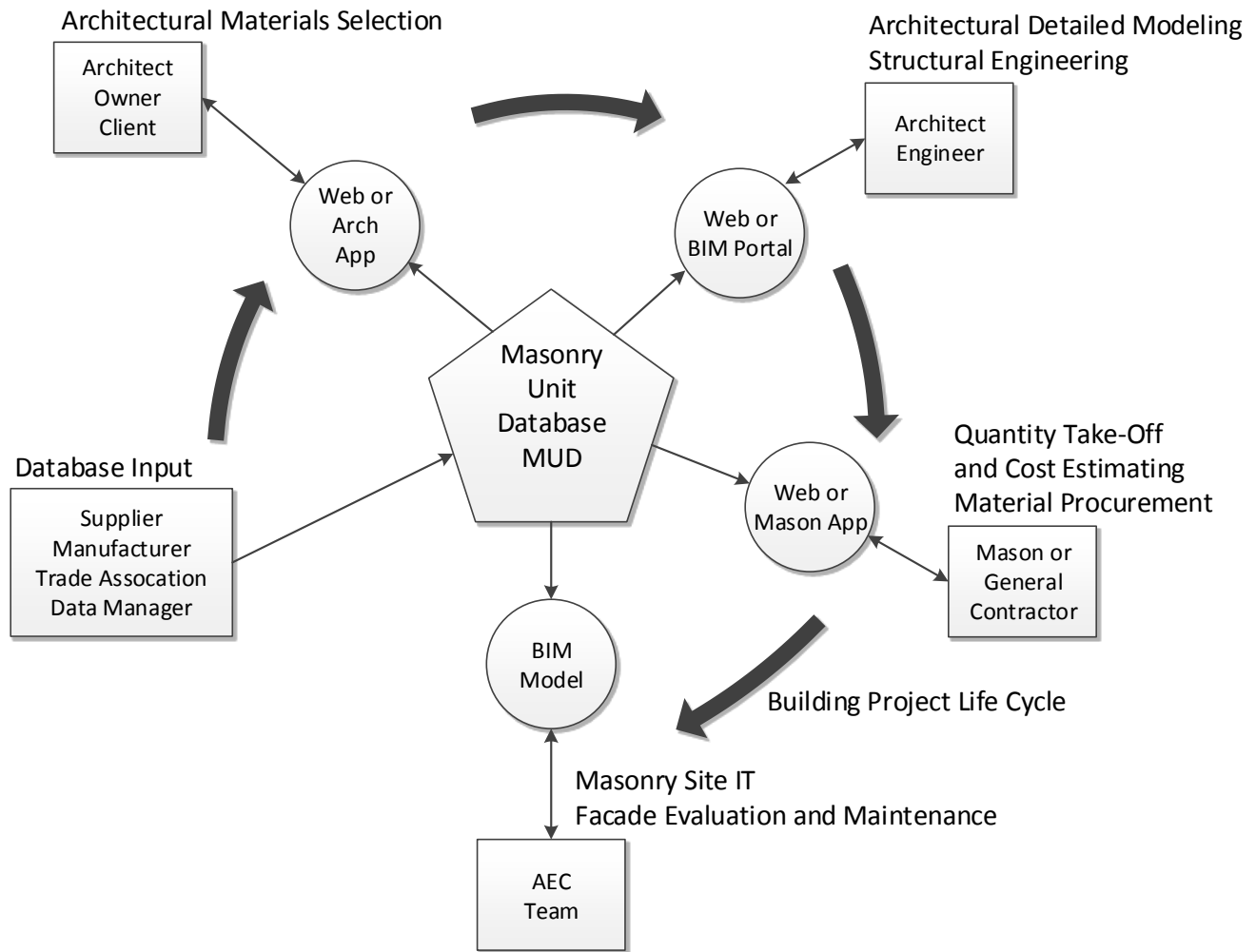

Figure 2. Stakeholder and workflow model for the MUD.

3.1. Masonry Manufacturer

The masonry manufacturer is primarily a producer of masonry units and in this role is likely to author much of the information into the MUD. The masonry supply chain is not homogeneous – in some cases the masonry manufacturer markets and sells masonry units directly to contractors, and in other cases the manufacturer sells to a supplier – who stocks and supplies the units to contractors.

3.2. Masonry Supplier

In the context of this report, a masonry supplier is a vendor of masonry units but does not manufacture the units. Depending on the nature of the supply chain, the masonry supplier may be responsible for inputting information into the MUD.

3.3. Trade Association

The clay and concrete masonry market segments produce many *generic* masonry units³ meeting a nationally recognized specification that may include descriptions of geometry and physical properties. They also produce *specified* units which may be standardized in shape but custom only in terms of color and texture. In the case of these units, such as the ubiquitous 8x8x16 CMU (190x190x390 CMU in Canada) and the modular brick, it may be that industry trade associations that support the clay and concrete masonry industries will populate the MUD with these units – and that an attribute in the database will flag that the unit is generic, that is, its geometry and properties are correct in the database, but that the fields associate with cost, supplier, manufacturer, stocking, etc. are left blank. The generic units will be acceptable for early-stage design and BIM instantiation, but will not work downstream for cost-estimating, for example.

3.4. Data Manager

The “data manager” stakeholder is speculative at this time but represents a business entity who is responsible for the collection, validation, input and maintenance of the data in the MUD. If the MUD grows to support electronic commerce and construction information technology, in addition to its clear role as a data repository for BIM, then the need for reliable data is clear. Given the range of company sizes in the masonry supply industry, from small companies with one plant to vertically-integrated companies with worldwide operations, it is clear that not every company will have the resources to maintain their MUD data internally. Therefore, it is suggested that the role of the data manager be thoroughly explored as the MUD is implemented. The masonry supplier industry trade associations may take on this role initially.

3.5. Building Owner/Client

The building owner or client may be interested in reviewing masonry materials that complement existing building stock. Or, in residential construction (which is not the specific focus of BIM-M), the owner/client may be directly involved in picking the masonry materials. For this stakeholder, the primary information that the stakeholder will be looking for is appearance, price, and availability.

3.6. Architect

The architect will interact with masonry unit information in multiple stages of the design process, with the three most important being: materials selection, detailed design, and construction documents (including specification writing). These workflows and interactions are described in detail in our previous report. The architect requires a full range of information regarding masonry units including aesthetic, geometric, physical properties, and price.

3.7. Structural Engineer

The structural engineer is primarily concerned about the geometric and physical properties of the masonry units. In many cases, the unit properties must be considered along with the properties of allied materials (grout, reinforcement) to develop overall properties of masonry walls. The intent is to include as much

³ *Generic* units are described as those units meeting a specification that freely allows for product substitution between suppliers. Related to the term *generic* units are *specified* units, which cannot be substituted between suppliers without permission from the design team, and *custom* units, which are manufactured specifically for the building project.

unit-level property data as necessary, so that structural design can be completed with information stored in the MUD.

3.8. Energy Analyst

The energy analyst also requires geometric and physical property data – and builds thermal characteristics of masonry walls from the thermal resistivity, surface characteristics, and density of the masonry units.

3.9. Mason Contractor

The mason contractor, like the architect, needs the complete range of masonry unit data depending on the phase of the project. In many cases the mason contractor may need appearance data in order to match existing units or to compare between units for product substitution. The mason contractor will also need information about coverage (that is, how many units are required per unit area of wall), price and availability to prepare cost estimates. It may be that the pricing data stored in the MUD will be valid only for preliminary pricing, and so workflows will be required that allow for cost-estimating to be updated during the QTO/Cost Estimating process.

3.10. General Contractor

The general contractor may have the same data needs as the mason contractor, but to a less detailed level. Many sophisticated GCs who practice “Virtual Design and Construction” are building high level of development (LOD) BIM models and these GCs are likely to access the geometric parts of the MUD in order to have the geometry of the masonry units. The concept of Levels of Development (sometimes referred to as Levels of Detail) or LOD in a BIM model come from idea of increasingly complex level of description of the elements in a building model as the model goes from LOD 100 (the most schematically described building model populated with few objects) to LOD 500 (a BIM model with an almost complete level of description including detailed objects and field verification of as-built information).

3.11. Software Supplier

Software suppliers may mine the MUD in order to convert the open-source geometric information found in the database into their proprietary graphic formats. These software links to the MUD are discussed in greater detail in Section 5, below.

4. Scenarios of Use

The scenarios of use can be thought of as high-level workflows without the detail of data exchanges and data formats. There are many scenarios of use for the MUD, but four major scenarios are highlighted here. As BIM-M stakeholders review the proposed data schema described in Section 6 below, they should think of their own scenarios of use and ask the question: “Is the information I need about masonry units available in the database?” If the answer is NO, then we need to hear from you about what is missing.

4.1. Material selection for aesthetics

Material selection for aesthetics involves primarily the shape, color and texture of masonry units. There are many nuances here, and in commercial construction, the selection of masonry units and associated materials (accent stone, grout, flashing) often involve the production of physical sample boards or mock-ups because digital information does not do a good job of demonstrating or promoting the “patina” that comes with masonry. In order to promote the use of the MUD for aesthetic decision making, the database

will provide for storage of graphic bitmaps representing images of the finished faces of the units. The database will accommodate⁴ multiple instances of the same view, so that in an array of these randomized images will show the approximate variation across the range of units. See also the discussion of the Masonry Designer software, in Section 5, below.

4.2. Importing geometry into BIM or CAD

In many cases, an architect (or any stakeholder attempting to create a high level of detail model) will want to insert the 3D or 2D geometry of the masonry unit into a BIM or CAD model. The database will accommodate this by storing both 3D models and 2D drawings of the required graphic information. Common file formats for these models/drawings are DXF (AutoCad drawing exchange format), RVA (Revit), Parasolid, and SketchUp Component. We believe that if these four file types are stored, we will have almost complete coverage in the BIM/CAD world.

4.3. Wall material property determination

A structural engineer or energy analyst will need to access the MUD in order to calculate structural or thermal properties of masonry assemblies (walls). It is for this reason that the geometric properties of generic masonry units are stored as descriptors instead of as 3D solid models, and so, for example, the face shell thickness of a block can be determined directly from the database, without having to load a BIM model and query the model for that thickness. In some situations, this query will be completed through a web application that provides the information to the engineer, but it will also be easy to tie the MUD to Excel or other programs so that wall properties can be calculated automatically using third-party programs that query the MUD.

4.4. Determining material availability

A final scenario for the MUD is the determination of material availability. This is a typical application of databases that manage inventory, but that functionality has not been envisioned for the MUD, because at this time the MUD is not seen as a full ERP (enterprise resource planning) database for internal business processes. Nevertheless, the MUD can be a first step for a masonry customer in determining whether a given masonry unit is stocked or custom, what the minimum order quantity is likely to be, and whether it is produced within a given region of the country (which is often of interest in projects seeking a LEED rating).

5. Software Applications and their Access to the Masonry Unit Database

In this section, existing software applications that access masonry unit information are briefly reviewed, and their potential linkage to the MUD is discussed. It is important that the development of the MUD facilitate, and not hinder, the advancement of these software programs. Therefore, the review of the proposed data model by these software vendors is critical in moving ahead with the MUD. Many software programs already use internal data models that include custom coding systems and masonry unit IDs. Many contain their own pricing or other data which is much more sophisticated than required for the MUD. The MUD should be expanded where necessary to accommodate these programs, but some consolidation of data schemes may be necessary if one data model (the MUD) is going to accommodate all masonry units.

⁴ When we say that the MUD “accommodates” or “stores” images or views or files, what is likely is that the database will store a link to that file, instead of containing the bitmap or file itself. A naming convention should be developed so that it is clear from the file name the information stored in the given file.

Note that the review here is not comprehensive – the applications discussed are meant to be illustrative of the software which is in use in the AEC industry today. In addition, the comments provided here are based on our understanding of the software applications from marketing literature and are not based on comprehensive knowledge of the internal operation of the software.

5.1. Masonry Designer

Masonry Designer is a software program used primarily in the brick masonry industry to demonstrate the aesthetic properties of masonry. It uses images of bricks in various bonding patterns and with various grout colors to aid in masonry selection. It allows for the development of custom two-dimensional brick patterns. Brick vendors that do not use Masonry Designer often have web-based tools or other virtual “sample board” generators that fulfill this function. For example, Acme Brick has an additional add-in to Autodesk Revit that creates a Revit family from the Masonry Designer palette built by the user.

5.2. Tradesmen’s OS3DE

Tradesmen’s is a quantity take-off and cost-estimating tool tailored specifically for the mason contractor. Because of its strong graphical interface, it has also been used for project planning and even project conception. At this point, Tradesmen’s focuses on the mason contractor and its internal data structure allows the contractor to keep historical pricing data and develop rules for the quantity estimation of masonry accessories such as mortar, grout, rebar, etc. Tradesmen’s will clearly benefit from access to the MUD, but the Georgia Tech team will need substantive feedback to see what can and cannot be contained with the general purpose data model proposed for the MUD, which is not focused on cost estimating. And so, for example, at this time we only have one cost number included in MUD (cost per unit) and one attribute for QTO (number of units per unit area of wall).

5.3. CADBLOX

CADBLOX is a masonry detailing tool used primarily in the concrete masonry industry for detailing concrete block walls with a large number of special units – usually with appearance grade concrete masonry units (CMU). The program was originally developed for the Trenwyth line of CMU, but is currently being expanded into other masonry types. The software is currently marketed as part of a service, and not as a stand-alone tool for use by architects, engineers and mason contractors. CADBLOX as it exists is the closest application to a LOD 350 or 400 BIM tool for masonry to date, as it provides a fully 3D model of the masonry walls, with each unit instantiated. Because CADBLOX was developed for special units with complex geometry, it should be easily adapted to read geometric information from the MUD.

5.4. Autodesk Revit

Autodesk Revit is the market leading BIM authoring tool in North America. It is widely used by architects, structural engineers and general contractors. In the current version of Revit, masonry units are not defined. Instead, masonry walls are defined as generic walls containing masonry layers. The masonry walls are identified via a “hatch” pattern but this pattern is not aligned with the masonry coursing nor does it recognize how masonry is coordinated at corners and openings. Until the underlying infrastructure of Revit changes, the best way to bring masonry into Revit is through the generation of Revit families for download by architects, as is currently done by many brick and appearance-grade CMU suppliers.

5.5. Bentley Ram Elements

Bentley Ram Elements is one of the few general purpose structural engineering analysis and design programs that explicitly include the capability of analyzing and designing masonry walls. In addition to the shell finite element analysis used to determine the in-plane and out-of-plane forces in the masonry walls, the application includes a masonry module and detailing module that allows for placement of openings and detailing of the reinforced masonry walls. The program requires the input of basic masonry wall properties but most of these are tied to the compressive strength of the masonry wall assemblage ($f'm$). Therefore, there is little to be gained from tying the structural analysis package to the MUD.

5.6. BIM Portals

BIM portals are aggregators of BIM information which can be searched and accessed from the web for pre-configured BIM objects, including masonry units and masonry walls. Current BIM portals⁵ include for example Autodesk Seek, SmartBIM, Arcat, RevitCity. The business model for BIM portals is to be paid to host the data of building product companies, and to provide information on the use of these models back to the these companies. Ultimately it may be one or more BIM Portals that agree to host the MUD, which will provide a common interface for web access to the MUD. In the fall of 2014, the Georgia Tech team will begin discussions with BIM Portal providers to gage their interest in hosting the MUD on a trial basis.

6. Database Organization

In the section below, the organization of the masonry unit database is described in detail. The section begins by providing a motivation for the organization of the database, and goes on to describe the overall entity-relationship model for the database. Finally, the section details each of the attributes to be contained in the relational database tables. A more compact view of the data schema, without the narrative, is provided in Appendix 1.

6.1. Engineering Units Representation in the Database

Many of the attributes will have engineering units associated with the properties (e.g., pounds, inches, psf). At this time, we recommend that the initial database values are input in units that agree with standard U.S. practice. This means that units will not be dimensionally consistent, as we typically specify strength in pounds per square inch (psi) but areal coverage in number of units per square foot. We recognize that the database may be used outside of the United States – and Canada is one of the partners in the BIM-M initiative. For metric output, it is possible to use derived attributes – that is, to have metric data calculated based on rules as opposed to having a completely separate metric database. This could be made transparent to the user. All the user would have to do is to check a “metric user” flag when they entered the database portal.

The other option is to have completely separate entries into the database for units sold in Canada. This may be required because of the difference between “hard metric” and “soft metric” conversions. Many Canadian units, for example, are 390 mm. In a soft metric conversion, a 15 5/8 inch unit dimension would be translated as 397 mm. In a hard metric conversion, the results of the conversion

⁵ Masonry suppliers are encouraged to visit these web portals and perform searches on them with the following questions in mind: Are your products featured? Do the keyword searches bring up the products you would expect? Is the product information provided correct?

might be made more rational, and the unit dimension might be given as 400 mm (or 40 cm). It is difficult to develop an algorithm to make hard metric conversions.

Though it adds complexity, it seems that both options may have to be considered, because, in some instances, there are masonry units made according to U.S. standard practice which are sold into Canadian and other metric markets, so a soft metric conversion is proper. In other cases, tooling is made specific to Canadian and other metric markets, so a hard metric conversion is appropriate.

6.2. Role of Classification

The first step in any database design process is requirements collection, analysis and classification. The detailed data is gathered from available resources and prospective database users. In addition to data requirement specification, the functional requirements and transactions for the retrieval and update of database also have to be identified. In the next step, a conceptual schema for the database with a high-level conceptual data model has to be created. For MUD, we have acquired entity-relationship model (ER model) that has the ability to describe in detail the entity types, relationships, and constraints of masonry units. Conceptual schema is easier to understand and communicate with nontechnical users, as concepts do not represent implementation and storage details. Readability by nontechnical users is an important aspect that ensures the complete identification of users' data requirements and prevention of any possible requirements conflict. In addition, in conceptual schema design phase the ER model operations can be acquired to determine the high-level user queries and operations.

6.3. Conceptual Schema Framework

At this level, we represent the related and required data to masonry units in an entity-relationship model (ER model), a high-level abstract method of organizing data to be later be implemented in a database application (i.e. a particular database and the associated programs that implement the database queries and updates). The ER model describes data as *entities*, *relationships*, and *attributes* (see Figure 3).

Entity, the basic object represented in ER model, represents a *thing* in the real world with an independent existence, an object with a physical or conceptual existence. Each entity is described with particular properties that are called the **attributes** of the entity. Any particular entity will have value for each of its attributes, which are the major part of the data stored in the database. Different types of attributes in the ER model are: *simple* versus *composite*, *single-valued* versus *multivalued*, and *stored* versus *derived*. In ER model, **relationships** represent references of entities types to each other. In other words, a relationship defines a set of associations among entities.

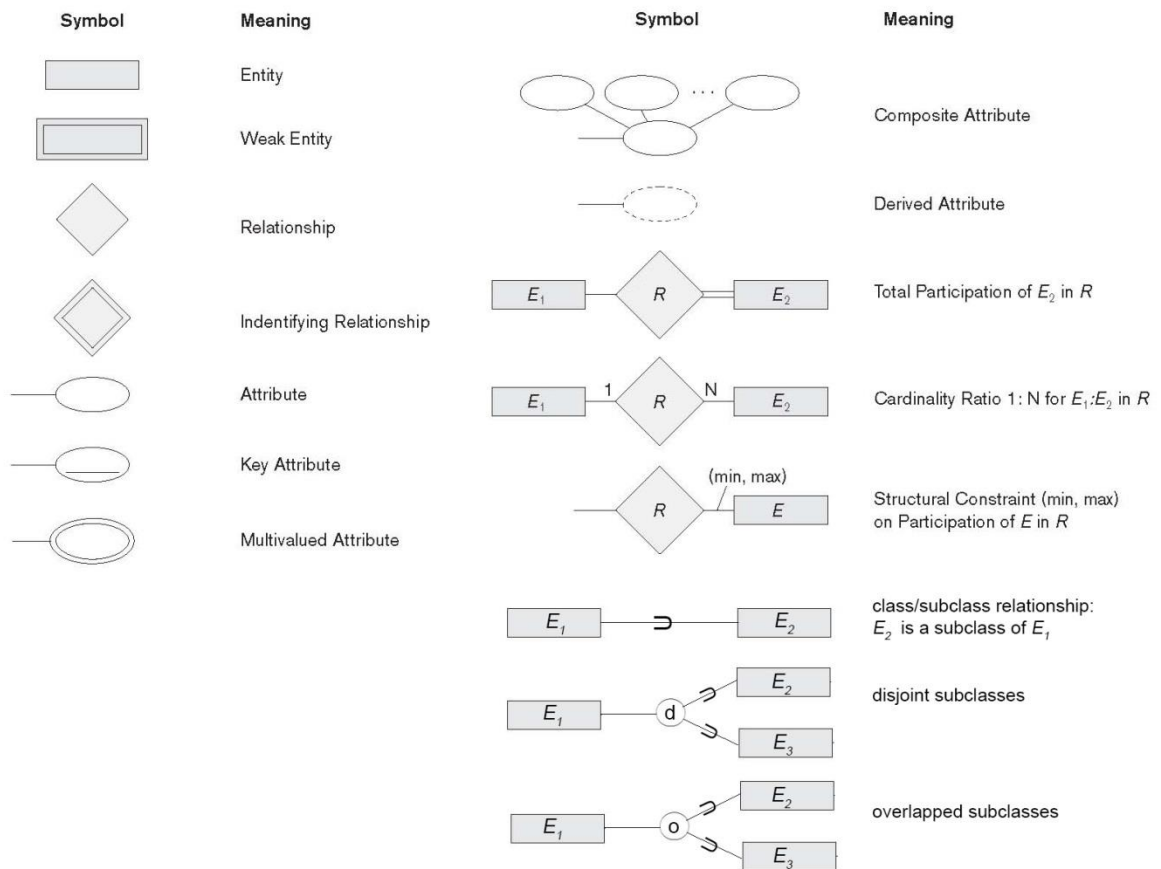

Figure 3. Summary of the notation for EER (Enhanced Entity Relationship) diagrams

In this project, we used the Enhanced ER (EER) model which is more suitable for newer applications of database technology including databases for design and manufacturing (CAD/CAM). EER model has additional semantic data modeling concepts incorporated into the ER conceptual data model. Among these concepts are *class/subclass relationships* and *type inheritance*. In a **superclass/subclass** or **supertype/subtype** relationship, every entity that is a member of a subclass is also a member of the superclass, but in a distinct specific role. The concept of inheritance means that every member of the subclass has its own specific attributes as well as inheriting all the attributes of its superclass. The entity also inherits all the relationships in which the superclass participates.

6.4. Masonry Overall Schema

The geometric and non-geometric masonry unit data are classified and represented in an EER model. We argue that the main data required for MUD can be categorized into the internal and external data to the units. Internal data to the units are represented as *geometry*, *material*, *physical properties*, *color*, and *texture* entities (Figure 4). These entities, along with their associated attributes and the relationship among them are required for activities such as unit specification, comparison, and selection. The external unit data is categorized as *manufacturer*, *supplier* and *project* entities, which are required for business activities such as cost estimation, availability query, and unit of order verification.

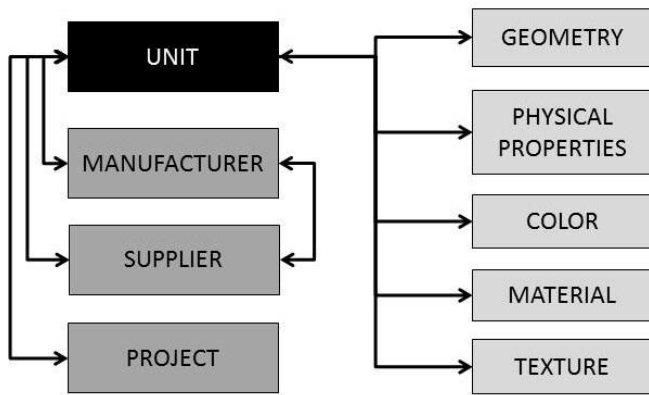

Figure 4: Main masonry unit entities to be represented in the EER model and MUD database.

The complete MUD EER model includes these entities and their associated attributes and the relationship between the entities. Relationships in this model, such as `MADE_BY` relating `UNIT` entity to `MANUFACTURER` entity, define a set of associations that are required for the adequate functionality of the MUD. For example the `DISTRIBUTED_BY` relationship between `UNIT` and `SUPPLIER` entity sets would be utilized in the query of specific masonry unit availability, cost or suppliers' location. The complete network of all MUD entities, attributes, and relationships is represented Figure 5.

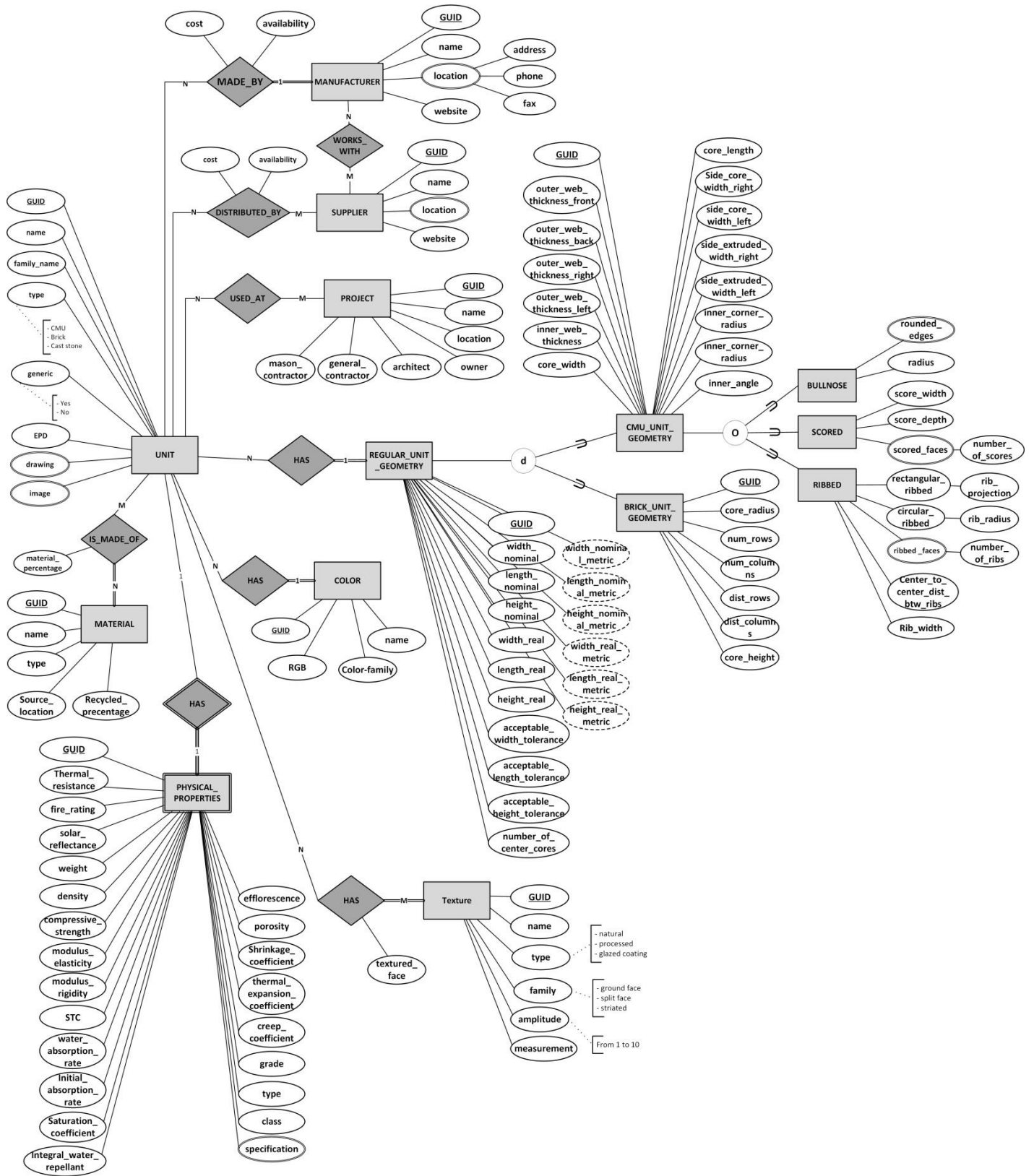

Figure 5. MUD complete EER model. (Portions of this figure are expanded throughout the text for readability)

6.5. Individual Entities

In this section, each entity and the attributes associated with that entity in the EER model are be described.

6.5.1. Unit

The core of the MUD schema model is the UNIT entity which represents all the masonry units that is going to be represented in this database. There are different attributes that their values define this entity: GUID (Globally Unique ID), name, family name, type, and image and drawing. UNIT entity like all other entities in this model has a GUID attribute that is used for unique identification of each entity in the entity set. Name attribute denotes the commercial name that manufacturers specify for their masonry product. In addition, these units can have a family name that will be used for grouping of a set masonry units with similar characteristics. Type attribute at the high level classifies the masonry products and includes Concrete Masonry Unit (CMU), clay brick and cast stone masonry. The UNIT entity also stores (string) values for images or drawing file locations provided by masonry units manufacturers.

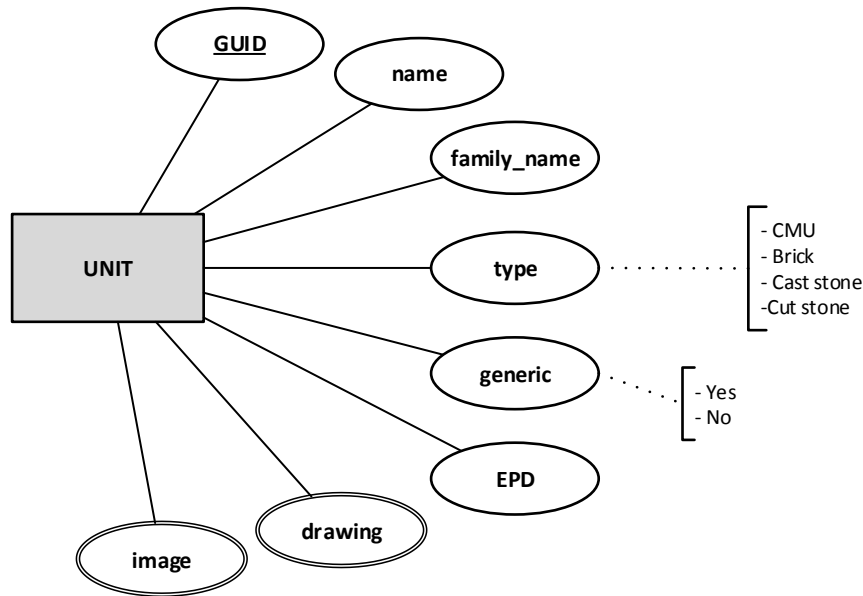

Figure 6. UNIT entity and its attributes.

6.5.2. Geometry

The most substantial entity defined in MUD is GEOMETRY, and the defined entity should be able to represent the geometry of both CMU and clay brick masonry units (Figure 7). The parametric geometry developed for CMU will in many instances be appropriate for structural clay units.

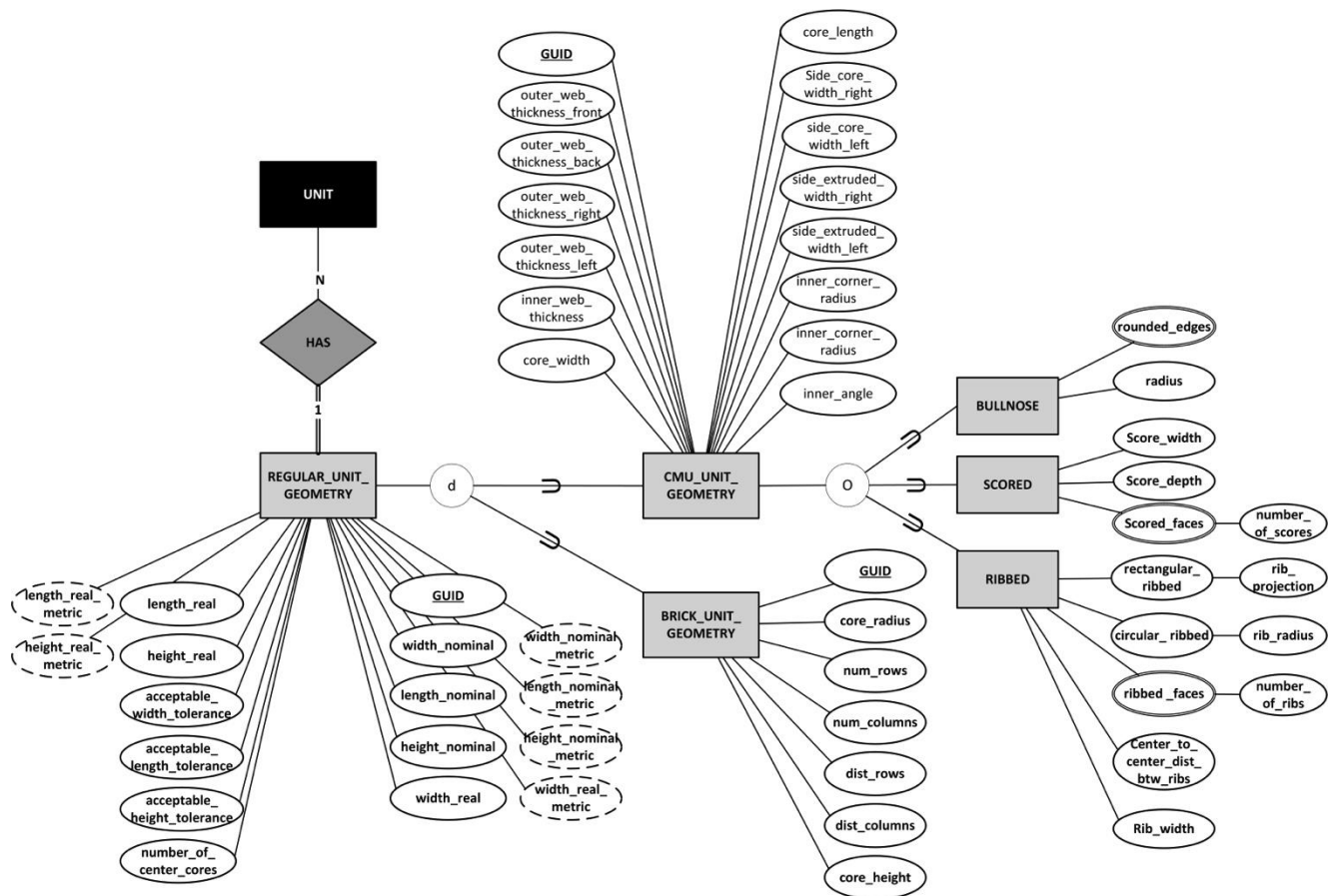

Figure 7. GEOMETRY entity, its subclass entities and their attributes.

For the development of MUD, we classify the units' geometry in three general categories: A) regular masonry unit geometry, B) special masonry unit geometry, and C) custom masonry unit geometry. The regular unit geometry is the major focus of MUD at this stage of development.

The geometry attributes were developed so that a wide range of common units could be represented parametrically as regular units but also so that the database could be easily understood without hundreds of parameters.

A) Regular unit geometry: the geometry of these units can be fully identified and categorized based on their parametric attributes. These units are produced by most masonry manufacturers with almost identical size and shape, although with different tolerances (Figure 8). Based on the assigned values to these attributes, each masonry unit can be identically 3D generated with the stored data in the MUD. CMU general units have parent families including stretcher, pier, corner, return corner, sash, corner sash, bond beam, conduit, lintel, open end, header, starter, and subtype groups such as bullnose, scored, ribbed (circular, rectangular). The clay bricks have two major categories of molded bricks and extruded bricks, and with parent families including thin brick, face brick, structural brick, pavers, etc. For clay units, cores and frogs can be represented as regular units.

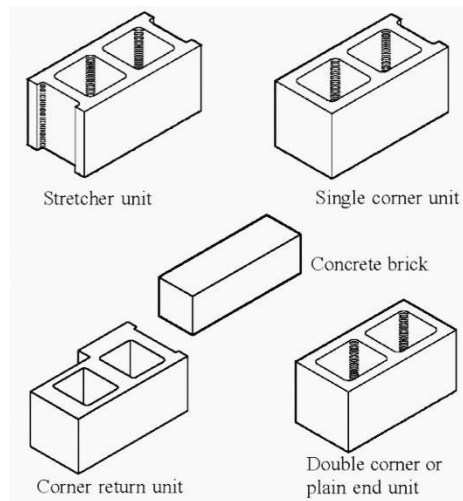

Figure 8. Typical Concrete Masonry Units which can be characterized as “regular” units.

B) Special unit geometry: these units inherit most of the attributes from the regular unit geometry, however they have some special geometric features which are unique to these units. These units are usually produced by one specific manufacturer based on their system of fabrication or particular preferences (Figure 9). Although these units can be partially represented by the parametric attributes that are defined for regular units, defining a set of parametric attributes to cover all their geometric aspects for a complete representation would be impractical, adding extensively to the complexity of the database data model. It will be up to the manufacturer whether they would like to represent their unit as a “special” unit, so that the overall shape and key features can be generated parametrically, or whether they would like to represent the unit as a custom shape.

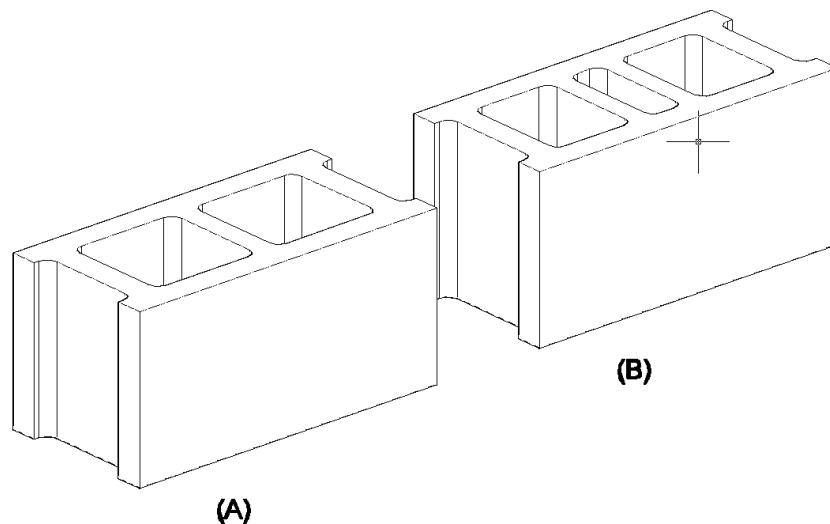

Figure 9. Masonry unit with special geometry (B) can be represented parametrically in the database as a regular unit (A). Non-geometric attributes such as unit weight can be corrected to properly represent the weight of the unit.

C) Custom unit geometry: these units are custom design by the request of the project architect or they are specific to a manufacturer or have such complex geometry that they cannot be represented parametrically (Figure 10). It is likely that many of the cast and cut stone units will ultimately have to be represented as custom units. Their geometry is usually complex and includes almost none of the geometric attributes of the regular masonry units. Geometry of these units is one of a kind, and as a result, parameterizing their geometric features would not be practical. Consequently, these units have to be represented with B-rep (Boundary representation) or CSG (Constructive Solid Geometry) models and to be stored as string data format or 3D files in the database.

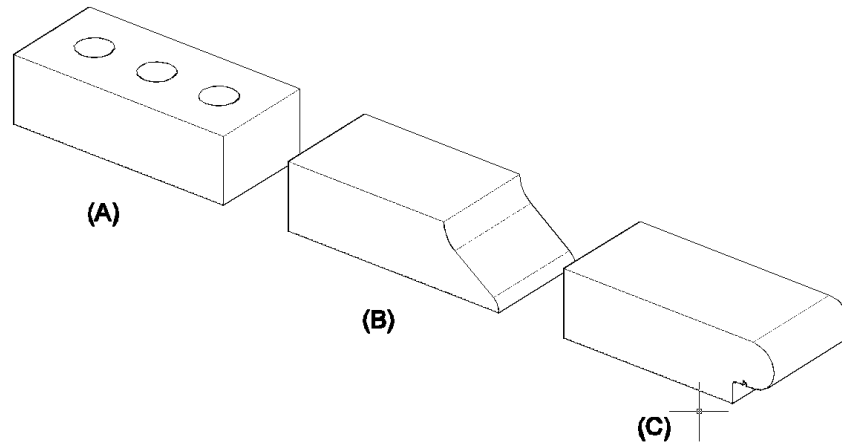

Figure 10. Custom Units (B) and (C) may be accessory units that are related to a regular unit (A).

UNIT Dimensions

Typically, CMU and clay brick units are defined with both nominal and actual dimensions. Nominal dimensions refer to unit size for planning bond patterns and modular layout with respect to door and window openings. Nominal dimensions may vary from the actual dimensions by the thickness of a mortar joint, typically 3/8 inch less than nominal dimensions but not more than 1/2 inch (9 to 12 mm). Actual dimensions refer to the real measured size of a particular unit. The actual dimensions of masonry units are usually 3/8 inch less than nominal dimensions in most masonry units, not accounting for including any adjacent or expected thickness or mortar joints, which is typical for expressions of nominal thickness.

In the US, CMU have nominal face dimensions of 8 in. (20 cm) by 16 in. (40 cm), available in nominal thicknesses of 4, 6, 8, 10, and 12 in. (10, 15, 20, 25, and 30 cm). As actual dimensions are typically 3/8 in. (9) less than nominal dimensions, so that the 4 or 8 in. (102 or 203 mm) module is maintained with 3/8 in. (9.5 mm) mortar joints (Figure 11).

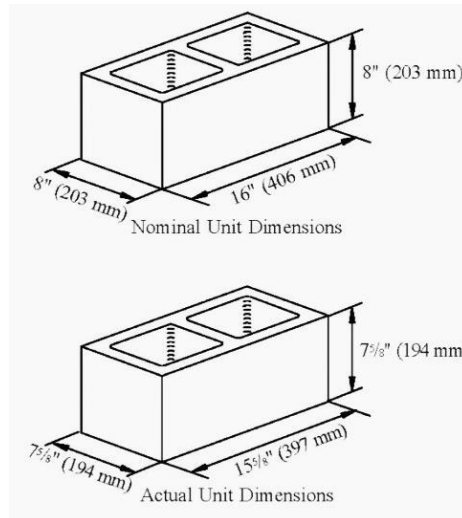
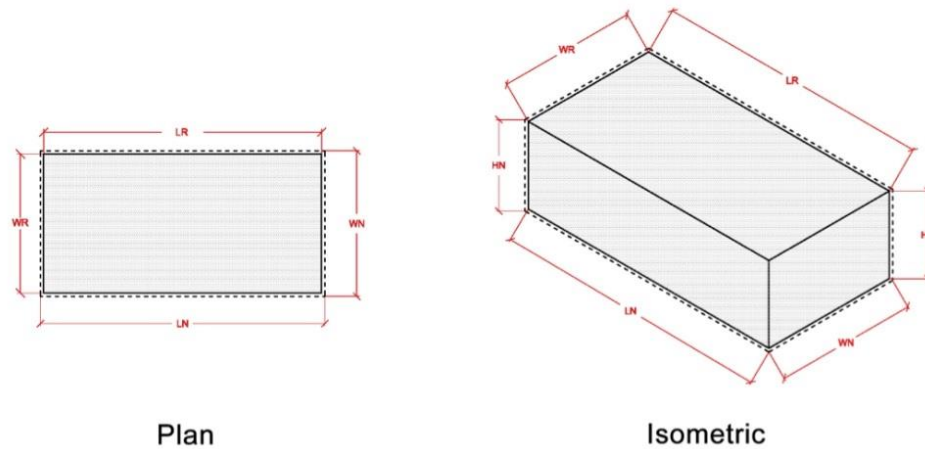

Figure 11. CMU for U.S. markets, nominal and actual unit dimensions. Metric dimensions depict the “soft” metric conversion.

Parametric Geometric Attributes

For the identification of masonry both CMU and clay brick units, we have classified their geometric properties into different attributes. We anticipate that based on these defined attributes all regular geometric units can be adequately represented in the database and regenerated in BIM applications. Because the geometry can be generated parametrically, the storage of the geometry is compact and all of the units do not need to be drawn in CAD. Figures 12A and 12B illustrates these attributes for concrete masonry units. Figure 13 illustrates these attributes for clay brick units.



GUID	Globally unique ID	HR	Height Real
WN	Width nominal	WR_T	acceptable width tolerance
LN	Length nominal	LR_T	acceptable length tolerance
HN	Height Nominal	HR_T	acceptable height tolerance
WR	Width Real	NC_C	Number of Center Cores
LR	Length Real		

Figure 12A. Attributes description, REGULAR_UNIT_GEOMETRY entity.

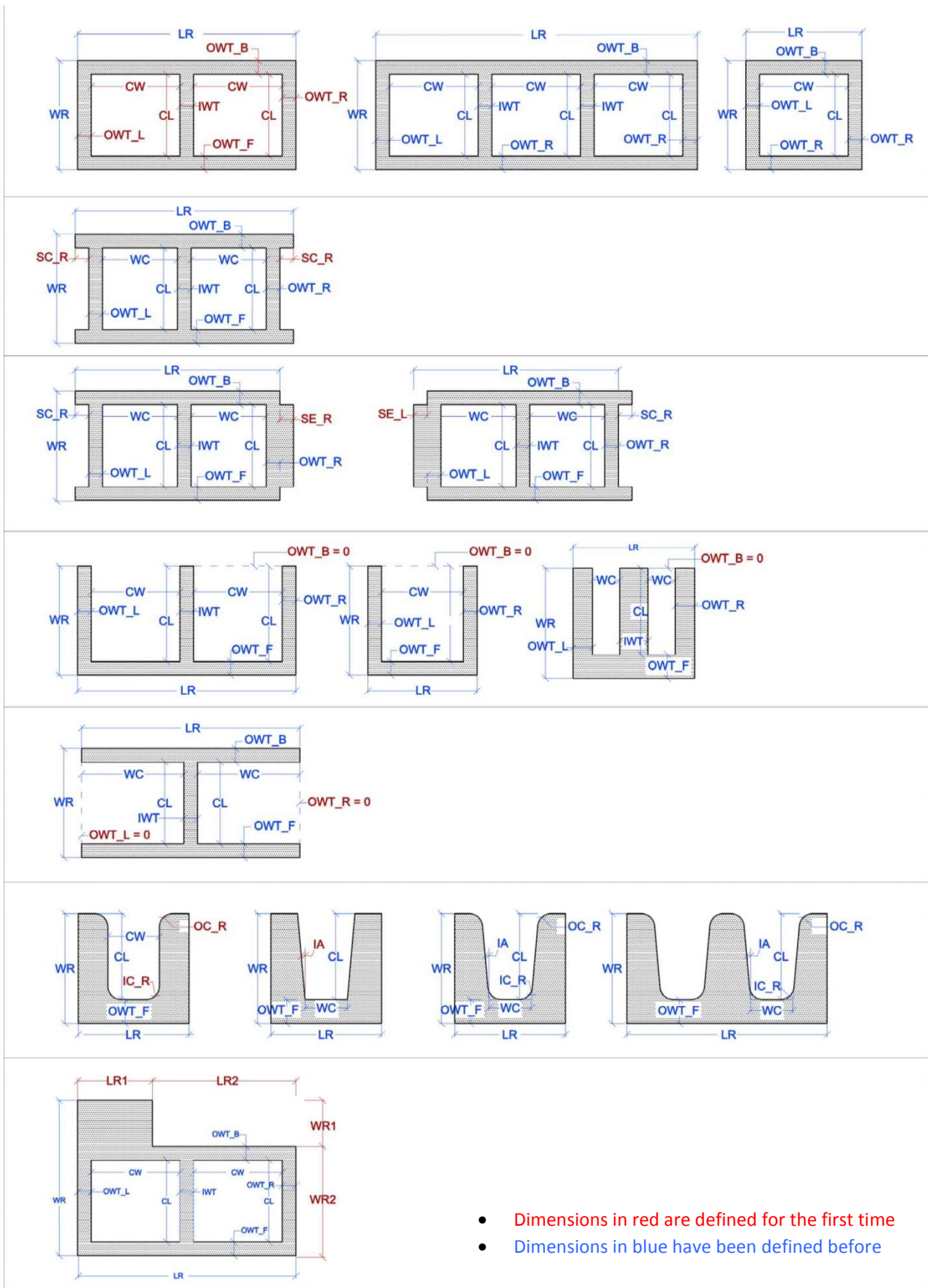

- Dimensions in red are defined for the first time
- Dimensions in blue have been defined before

WR1, WR2	L-Shape blocks	CL	Core Length
LR1, LR2	L-Shape blocks	SC_R	side core - width – right
OWT_F	Outer web thickness Front	SC_L	side core- width - left
OWT_B	Outer web thickness Back	SE_R	side extruded width- right
OWT_R	Outer web thickness Right	SE_L	side extruded width- left
OWT_L	Outer web thickness Left	OC_R	Outer Corner radius
IWT	Inner Web thickness	IC_R	Inner Corner radius
CW	Core width	IA	Inner Angle

Figure 12B. Attributes description, CMU_UNIT_GEOMETRY entity, continued.

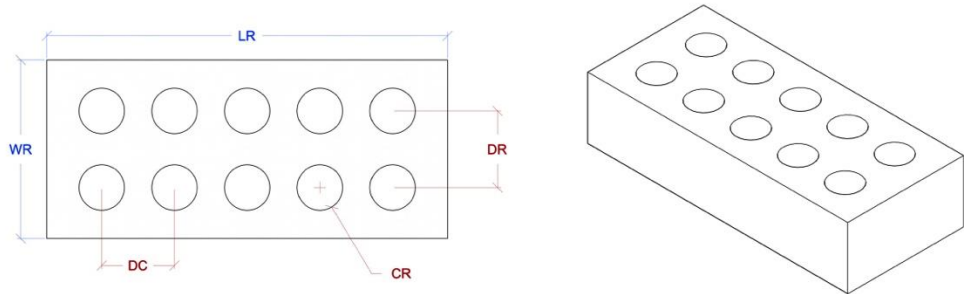

CR	core radius	DC	distance between columns
NC	number of columns	DR	distance between rows
NR	number of rows	CH	core height

Figure 13. Attributes description, BRICK_UNIT_GEOMETRY entity.

6.5.3. Texture

The texture of a masonry unit is an indicator of its appearance, feel, and consistency of a surface. Texture can be defined as the pattern or configuration apparent in an exposed surface of a masonry unit, including roughness, streaking, striation, or departure from flatness. Because the texture is mapped to faces, it is necessary to map the faces and edges of the masonry unit. The convention for doing so is given in Figure 14. Texture applies to both clay and concrete masonry units, but the language used to describe the textures varies depends on the material type. When the database is extended to cast and cut stone, an even more extensive discussion of texture will need to be included. The intent here is to embody both the manufacturer’s description of texture including adjectives like “antique”, “struck”, and “rolled” as well as a numerical scale so that architects can search for units with similar texture. So, for example, searching for a texture amplitude of 1 will return units with absolutely flat surfaces like glazed and ground units. Searching for a texture of 10 will return units with split, slumped and highly irregular faces.

In concrete masonry, texture is closely related to the depth of the natural aggregates and the processes such as machining polish, exposing, buffing the aggregates or glazing that have been applied to the surface of a masonry unit. The attributes that we have defined for the specification of texture entity include texture type, texture family, texture amplitude, and texture measurement (Figure 15). The texture type is consisted of natural texture, processed texture, or glazed coating (where applicable). The texture family for CMU for example includes split-face

(appearance of natural stone, rough-hewn texture with exposed aggregates), ground-face (polished surface finish produced by grinding machine), striated (random striated pattern), etc. The amplitude of the texture indicates the roughness or smoothness of the surface and is measured on the scale of 1 to 10. Measurement attributes could be represented using a quantitative assessment based on the measurement of masonry surface profiles using methods like that provided ASTM D7682, Standard Test Method for Replication and Measurement of Concrete Surface Profiles Using Replica Putty.

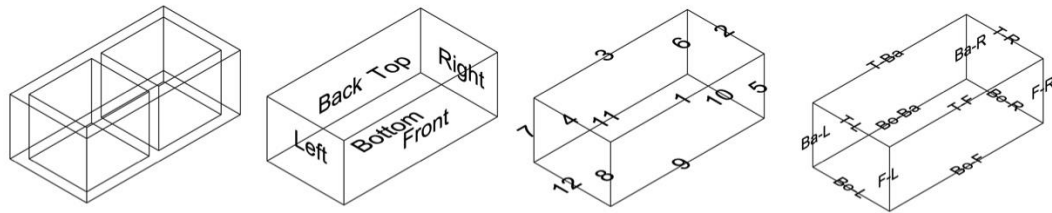

Figure 14. Naming of masonry units faces and edges.

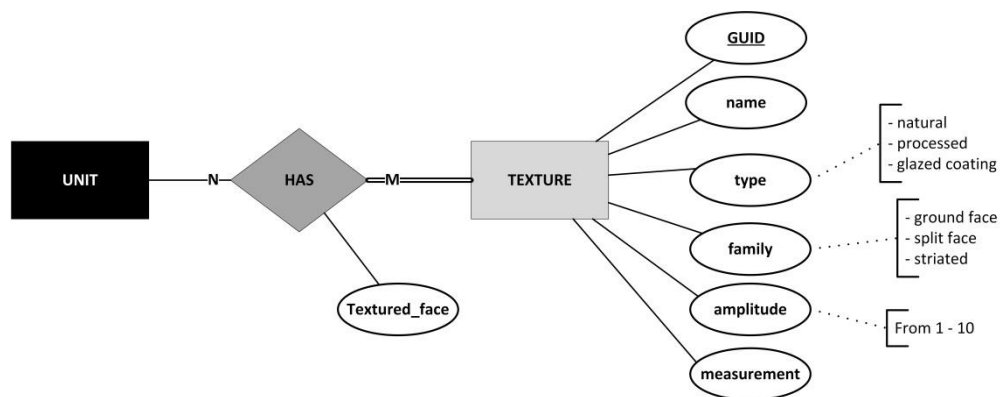

Figure 15. TEXTURE entity and its attributes.

6.5.4. Color

The masonry units color is the result of color ranges in raw materials, aggregate mix, added coloring agents or glazed color in case of glazed bricks. For example the factors that influence color variations in CMU include color variation in pigments, aggregates, cements, clay, water content, degree of compaction achieved during manufacture, and for brick include kiln conditions, changes in clay materials, and atmospheric conditions such as temperature and humidity. Masonry units color variations can be standard or special order. The assign attributes to the Color entity are RGB of the color, color name, and color family (Figure 16). The attribute color family is used to group like units together. Based on discussion with our users, it may be useful to add a second color family, so that a given unit can be identified as belonging to more than one color family (say brown and tan). It is also possible to add a amplitude measurement for “color uniformity”, where a brick with a large amount of color difference would have a low color

uniformity. Again, this is an area where the classification needs to be discussed, particularly with the brick industry.

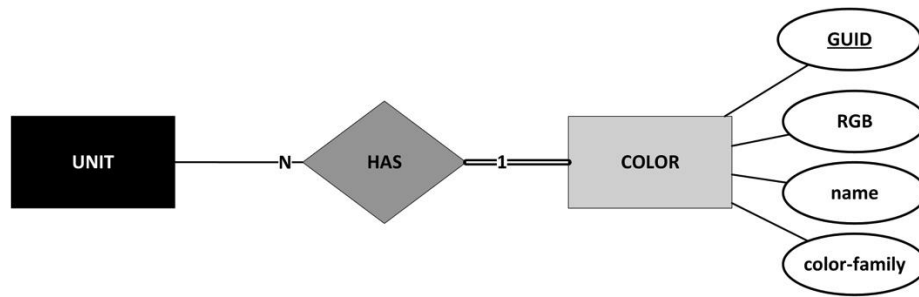

Figure 16. COLOR entity and its attributes.

6.5.5. Physical Properties

The Physical properties entity includes attributes for both mechanical properties and thermal properties of masonry units. These properties are determined based on ASTM (American Society for Testing and Materials) standards for the most part. The physical properties identified for inclusion in the MUD are shown in Figure 17.

It is not possible nor even desirable that the database represent the entire set of physical properties that a masonry unit might have. Instead, what is important is that those properties which are the basis of unit selection are represented (for example, “I need a unit which has a compressive strength greater than 3000 psi”). In the text below, key properties identified by the masonry industry and others identified by our research team are discussed. In addition to facilitating masonry unit selection, relevant properties of units are contained in the database so that the masonry wall models to come in Phase III of the research have sufficient information regarding masonry units, so that physical properties of walls, used for energy and structural analyses.

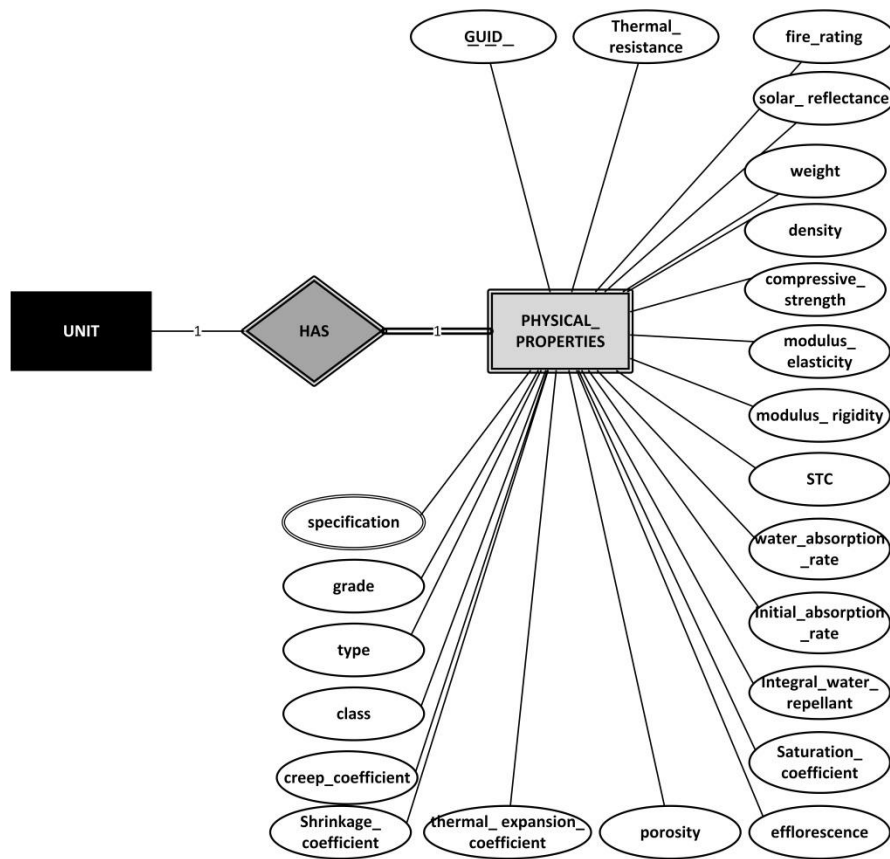

Figure 17. Physical Properties entity and its attributes (thermal and mechanical).

Thermal resistance:

Thermal Resistance or R-Value is the reciprocal of thermal conductivity. Thermal Resistance is correlated to masonry density, since thermal conductivity of material increases with increasing density [h·ft²·°F/BTU] or [K·m²/W]

Fire rating:

Based on building codes, critical building components must have a certain level of fire resistance to protect occupants and to allow a means of escape. Fire resistance rating or fire rating is defined as the duration of time not exceeding 4 hours that a building element, component or assembly maintains the ability to confine a fire, continues to perform a given structural function or both during a standardized test. The rating is not intended to represent actual performance.

Solar reflectance:

Solar reflectance of masonry opaque material is a surface property that is reflectance is measured on a scale of 0 to 1. In this scale, (0) represents not reflective (i.e. flat black) and (1.0) represents a perfectly reflective material surface. In general, light-colored materials have high solar reflectance and dark-colored materials have low solar reflectance.

Weight:

Weight is the specified weight of each unit [pounds] or [Kg].

Density:

Density is a measure of weight per unit of volume of a material or substance. Density can be used to identify a substance [pounds/ft³] or [Kg/m³].

Compressive Strength:

The compressive strength of masonry or $f'm$, is a performance characteristic used by engineers in the design of masonry structures. The strength of masonry units depends on the used raw materials, the manufacturing process and the shape and size of unit. Compressive strength is the maximum compressive force resisted per unit of net cross-sectional area of masonry, and is measured in pounds per square inch.

Modulus of Elasticity (Compressive Strength): The physical measure of a material to deform under the load. It is defined by the “ratio of normal stress to corresponding strain for tensile or compressive stresses below proportional limit of material”. [psi] or [MPa]

Modulus of rigidity (Diagonal Tension or Shear): “ratio of unit shear stress to unit shear strain for unit shear stress below the proportional limit of the material.” [psi] or [MPa]

STC (Sound Transmission Class):

“A single-number rating obtained by classifying the measured values of Sound Transmission Loss in accordance with ASTM Standard E 413 “Classification for Sound Rating Insulations” and TMS 302-12 “Standard Method for Determining the Sound Transmission Class Rating for Masonry Walls”. It provides a quick indication of the performance of a partition for certain common sound insulation problems”. STC ratings is based on weight of the block and whether the cells are filled or not and what material it is filled with if so. The STC number in Masonry Unit Database is based on the STC rating of a hollow masonry unit and we recognize that additional calculations are necessary to derive the STC of an entire wall assembly.

Cold Absorption: (CMU)

Cold absorption is method for concrete units and is tied to ASTM C140 Standard Test Methods for Sampling and Testing Concrete Masonry Units and Related Units. [percent]

Boiled Absorption: (Brick)

The boiled absorption is often used as a measure of brick durability. Brick manufacturers need to clarify whether they would like to have this attribute in the database. [percent]

Water absorption rate: (Brick)

Water absorption rate represents the amount of water that a dry brick unit can absorb in 24 hours period. Water absorption, % by mass, after 24 hours immersion in cold water is given by the formula: (M_1 : weight of dry brick, M_2 : weight of water absorbed brick).

$$W = \frac{M_2 - M_1}{M_1} \times 100$$

Initial Rate of Absorption: (Brick)

The initial rate of absorption (IRA) is the amount of water absorbed in one minute through the bed face of the brick. It is a measure of the brick's 'suction' and can be used as a factor in the design of mortars that will bond strongly with units.

Saturation Coefficient: (Brick)

"The saturation coefficient, also referred to as the C/B ratio, is the ratio of 24-hour cold water absorption to the five-hour boiling absorption" of masonry units. C/B ratio is an indication of the probable resistance of brick to freezing and thawing.

$$\text{Saturation coefficient} = (W_s^2 - W_d) / (W_b^5 - W_d)$$

Integral Water Repellent (IWR):

The integral water repellent is a yes/no attribute for CMU.

Efflorescence Resistance:

Efflorescence is a change on the surface of masonry unit to a powdery substance. This effect is due to the loss of water of crystallization from a hydrated or solvated salt on exposure to air. Efflorescence is usually a white powdery scum, but also can be brown green or yellow, depending on the type of salts in the masonry unit clay, cement or aggregates. This attribute will be defined with a yes/no value in database and actually refers to masonry units which are specifically marketed as "efflorescence resistant". We do not see this across industry product literature so it may not belong in the database.

Porosity:

Porosity or void percentage is a measure of void or empty spaces in the material of masonry units. It is measured by calculating the volume of voids over the total volume of a unit.

(V_V : volume of void-space, V_T : total or bulk volume of material)

$$\phi = \frac{V_V}{V_T}$$

Shrinkage Coefficient: (CMU)

Concrete masonry units shrink over time due to temperature decrease or moisture loss.

$K_m = 0.5 S_L$ (S_L : total linear drying shrinkage of concrete masonry units determined in accordance with ASTM C 426)

Coefficient of Thermal Expansion, CTE:

This is the relationship between change in dimension as it relates to change in temperature. Typically given in units of /°F in U.S. units and /°C in metric units.

Creep Coefficient: (CMU)

Creep is the tendency of material to deform permanently under the influence of long-term exposure to high-level mechanical stress. Creep of concrete in compression is determined in accordance with ASTM C 512)

Classification Attributes Related to Physical Properties

Four additional characteristics of the masonry unit are included as attributes to help differentiate the units based on application. In general, most masonry units meet one or more ASTM Standard Specifications. Within those specifications, there may be types, classes or grades that are related to physical properties of the units. At this time, these four attributes are included. Some brief discussion is included below so that the type of data that should be entered into these fields is clear. The examples given are based on ASTM C652, Standard Specification for Hollow Brick. At this point we believe that CMU are not “graded” according to physical attributes, but rather are specified by size, compressive strength, color, and texture. Therefore, CMU will have a “specification” but the grade, type and class fields will be empty.

Specification:

The standard specifications that masonry unit satisfies (defining the requirements to be satisfied by subject of the ASTM, American Society for Testing and Materials, technical standards). The attribute would be “ASTM C652”.

Grade: (Brick)

Brick grade is the “designation for durability of the unit expressed as SW for severe weathering, MW for moderate weathering, or NW for negligible weathering”. The grade attribute might also be important for concrete masonry units or cast stone – but the SW and MW do not make sense for those materials, as these are terms taken from ASTM C652.

Type: (Brick)

Brick type is the “designation for facing brick which controls tolerance, chippage and distortion, and expressed as FBS, FBX and FBA for solid brick, and HBS, HBX, HBA and HBB for hollow brick”.

Class: (Brick)

Brick type H40V is intended for uses where less void is desired, and type H60V is intended for use where more void is desired.

6.5.6. Material

Masonry units are made of combination of different raw materials created under different processes. CMU is made of a mixture of powdered Portland cement, water, sand, and gravel. Brick is made of natural clay minerals such as kaolin and shale and mixed with small amounts of additive components such as manganese and barium for production of color shades or improvement of chemical resistance. The listing of materials and their percentages is of particular interest on projects where the AEC team is pursuing LEED accreditation or trying to limit the embodied energy in the building.

In MUD, each UNIT is associated with different MATERIAL entities, each of which defined with material name, type, source location and recycled percentage (post-consumer and pre-consumer content) attributes. The relationship between UNIT and MATERIAL represents the percentage of each material used in each specific entity (Figure 18).

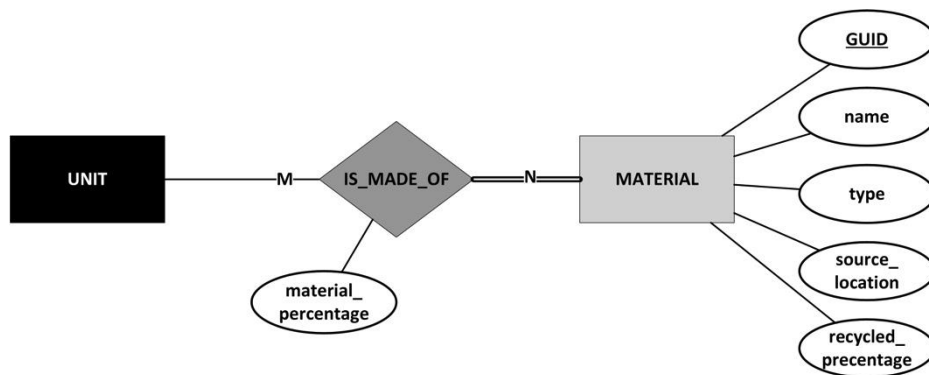

Figure 18. MATERIAL entity and its attributes.

6.5.7. Manufacturer

Manufacturer entity represents the information about the masonry unit manufacturers. The attributes associated with MANUFACTURER are attributes for identifying each company and includes name, location (address, phone, fax) and website. The relationship between each UNIT entity and MANUFACTURER entity is elaborated with two additional attributes, cost and availability of masonry units produced at that company (Figure 19). It may be that manufacturers want to remove all cost information from the MUD, as cost is a complex variable based on many factors. It is included at this time for discussion and completeness.

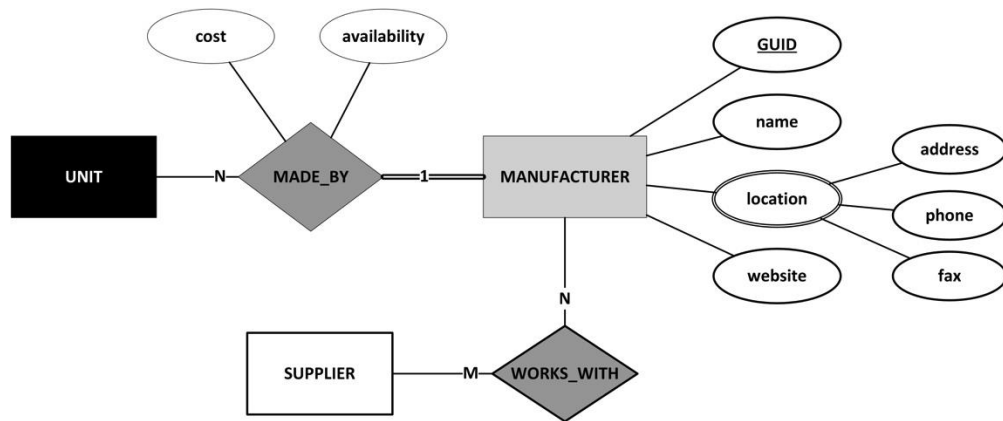

Figure 19. MANUFACTURER entity and its attributes.

6.5.8. Supplier

Masonry suppliers are the links between masonry manufacturers and the groups that are involved in the masonry selection and purchasing for any building project. The SUPPLIER entity in MUD is identified with attributes including name, location(s), and website. The relationship between this entity and UNIT entity has additional attributes, cost and availability. The attributes assigned to SUPPLIER entity and the DISTRIBUTED_BY relationship will be used for comparison and selection of masonry suppliers based on their location, the price they offer for a specific product and the stock availability. In addition, the SUPPLIER entity has an additional relationship, WORKS_WITH, which relates it to the MANUFACTURER entity.

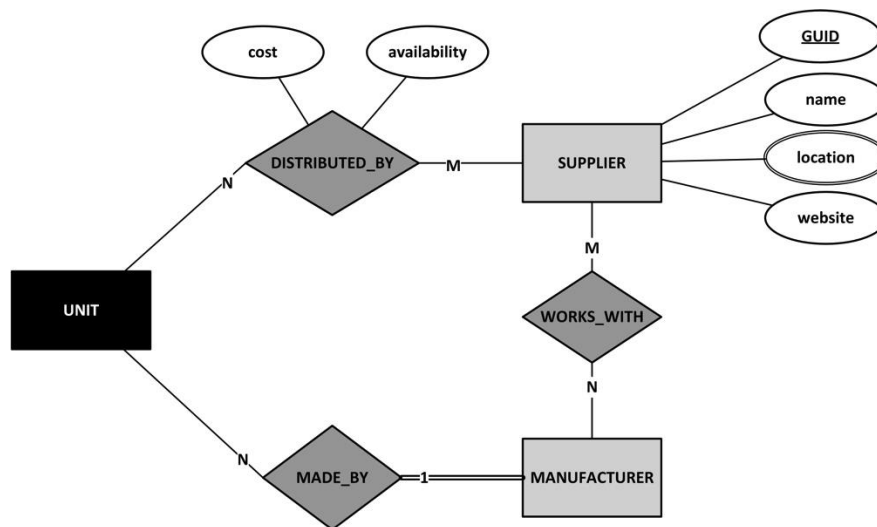

Figure 20: SUPPLIER entity and its attributes.

6.5.9. Project

PROJECT entity represents the building projects that the masonry units have been used in. Each project entity is defined by these attributes: name of the project, owner of the project, and project location.

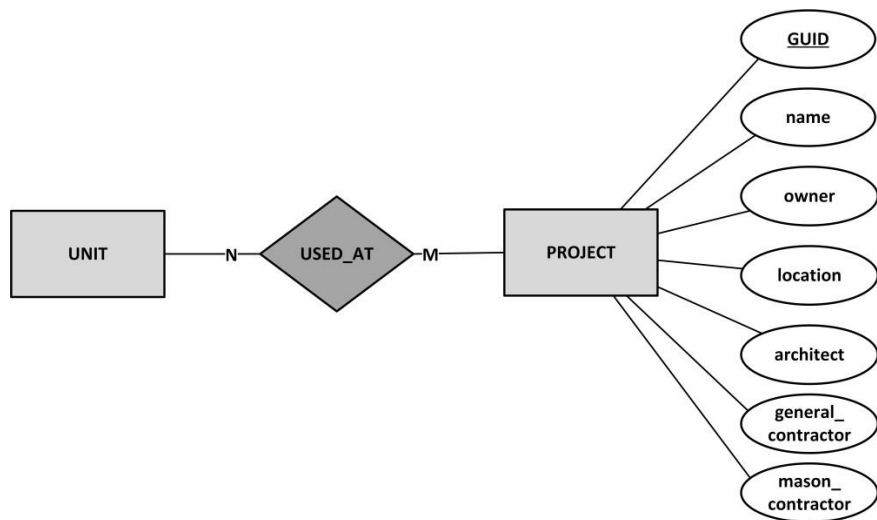

Figure 21: PROJECT entity and its attributes.

7. Industry Review of the Proposed MUD Schema

In the fall of 2014, we intend to implement the database with a small selection of masonry units – in an SQL data management system such as MySQL, and we would like for this database demonstration to be as comprehensive as possible. Therefore, a review of the data model by the current BIM-M community, and especially masonry suppliers and software providers, is critical at this time.

Members of the clay and concrete masonry unit community need to identify additional attributes that should be added to the database – along with the tables in which these attributes belong. The Masonry Supply Working Group (MSWG), under the direction of Jeff Elder, should also review the MUD and see if it meets the specification delivered by the group to us last year. We believe that it does.

Members of the MSWG who typically create custom units as part of their process should review their “top 10” shapes so see how many of their shapes can be classified as “regular” and “special” or “custom” as defined in this document. We recognize that the custom masonry workflow is not fully illustrated in the work of the Georgia Tech team at this time, as the focus has been on regular units. The feedback we need from the cast and cut stone communities is how they could benefit from having their materials in the MUD, even if only a limited selection of all of the possible unit geometries is represented.

Members of the BIM-M software community (who provide software for visualizing, cost-estimating and shop drawing production, for example) need to review the MUD proposed here to see whether and how the data contained in the MUD can support a wider acceptance of their products. They should comment on the translation required to map the generic data formats described here to the internal formats used in their software. The same review and feedback will be requested of the major BIM product portal providers. If data needs to be added to the MUD to support its implementation into product portals, we need to update the MUD schema to support these data sources.

Georgia Tech has is developing short presentations to accompany this report. A webinar has been scheduled in August to begin presenting this information to the masonry supply community, so that we can begin to actively solicit their feedback.

Appendix 1

The appendix below contains the relational database schema for the MUD. This is essentially an alternative view into the database from that provided in Section 6 but it shows clearly the relationship between the tables.

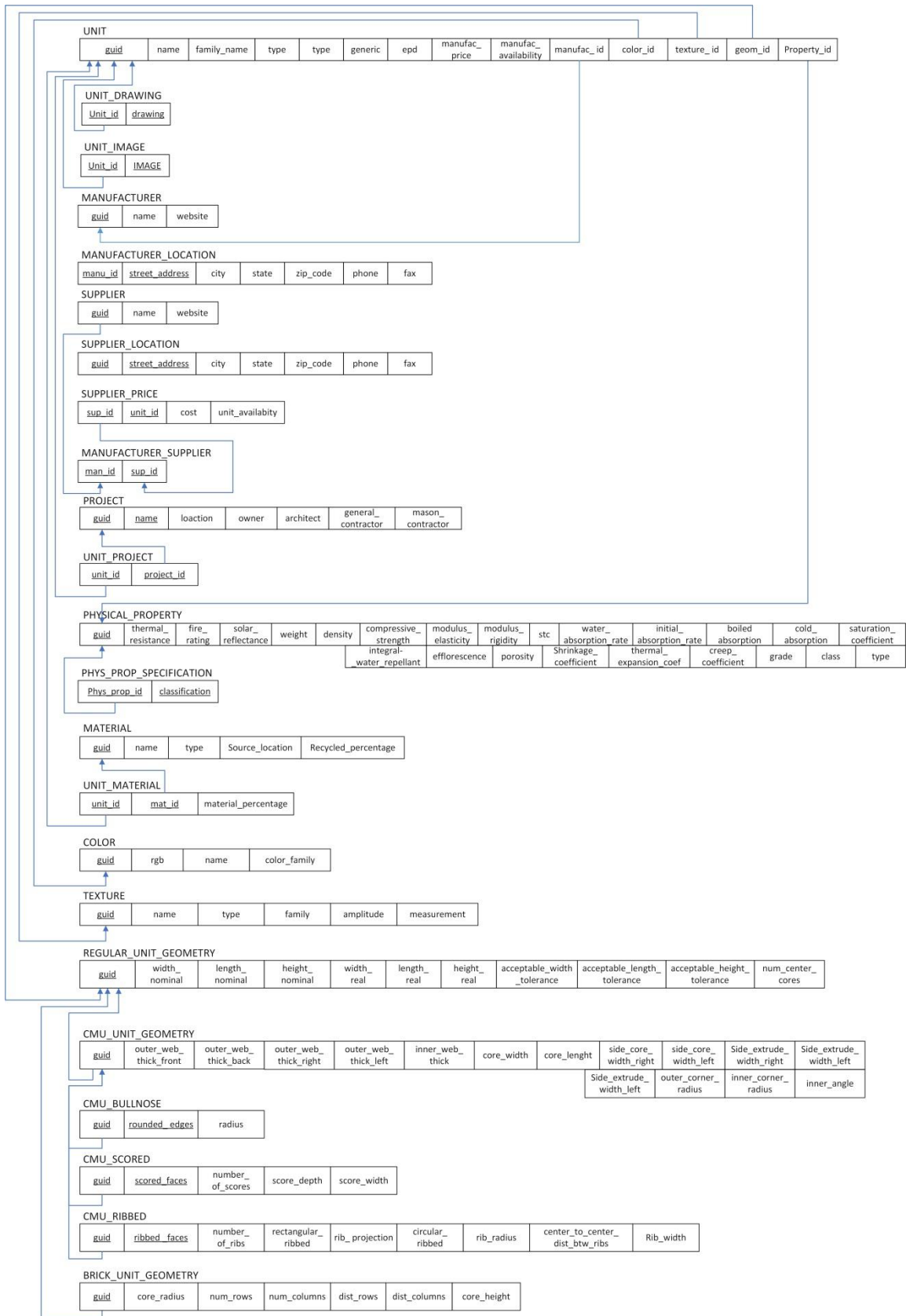

Figure 22. Masonry Unit Database relational database schema.

Relational Database Tables in the MUD

CREATE TABLE UNIT

(u_id	INT	NOT NULL,
u_name	VARCHAR (30)	NOT NULL,
cost	DECIMAL (10,5)	NULL,
availability	INT	NULL,
manufac_name	VARCHAR (50)	NOT NULL,
color_rgb	INT	NOT NULL,
texture_name	VARCHAR (100)	NOT NULL,
geom_id	INT	NOT NULL,
Property_id	INT	NOT NULL,

PRIMARY KEY (u_id),

FOREIGN KEY (manufac_name) **REFERENCES** MANUFACTURER (m_name),

FOREIGN KEY (color_rgb) **REFERENCES** COLOR (rgb),

FOREIGN KEY (texture_name) **REFERENCES** TEXTURE (t_name),

FOREIGN KEY (geom_id) **REFERENCES** GEOMETRY (g_id),

FOREIGN KEY (property_id) **REFERENCES** PHYSICAL_PROPERTIES (p_id));

CREATE TABLE MANUFACTURER

(m_name	VARCHAR (50)	NOT NULL,
street_address	VARCHAR (200)	NOT NULL,
city	CHAR (30)	NOT NULL,
state	CHAR(2)	NOT NULL,
zip_code	INT	NOT NULL,
phone	INT	NULL,
fax	INT	NULL,
website	VARCHAR (30)	NULL,

PRIMARY KEY (name));

CREATE TABLE PROJECT

(p_name	VARCHAR (30)	NOT NULL,
address	DECIMAL (10,5)	NOT NULL,
owner	DECIMAL (10,5)	NOT NULL,

PRIMARY KEY UNIT (u_id));

CREATE TABLE UNIT_PROJECT

(unit_id	INT	NOT NULL,
Project_name	VARCHAR (30)	NOT NULL,

PRIMARY KEY UNIT (unit_id, Project_name),

FOREIGN KEY (unit_id) **REFERENCES** UNIT (u_id),

FOREIGN KEY (project_name) **REFERENCES** PROJECT (p_name));

CREATE TABLE PHYSICAL_PROPERTIES

(p_id	INT	NOT NULL,
fire_rating	DECIMAL (10,5)	NULL,
Solar_reflectance	DECIMAL (10,5)	NULL,
Stc	DECIMAL (10,5)	NULL,
thermal_resistance	DECIMAL (10,5)	NULL,
density	DECIMAL (10,5)	NULL,
Strength	DECIMAL (10,5)	NULL,
Modulus	DECIMAL (10,5)	NULL,
Rupture_strength	DECIMAL (10,5)	NULL,

Tension_strength DECIMAL (10,5) NULL,
PRIMARY KEY UNIT (p_id));

CREATE TABLE MATERIAL

(m_name VARCHAR (100) NOT NULL,
type VARCHAR (100) NOT NULL,
Source_location VARCHAR (100) NOT NULL,
Recycled_percentage DECIMAL (2,2) NULL,
PRIMARY KEY UNIT (m_name));

CREATE TABLE UNIT_MATERIAL

(unit_id INT NOT NULL,
mat_name VARCHAR (100) NOT NULL,
Material_percentage DECIMAL (2,2) NULL,
PRIMARY KEY UNIT (unit_id, mat_name),
FOREIGN KEY (unit_id) **REFERENCES** UNIT (u_id),
FOREIGN KEY (mat_name) **REFERENCES** U MATERIAL (u m_name));

CREATE TABLE COLOR

(rgb INT NOT NULL,
name VARCHAR (30) NULL,
color_family VARCHAR (30) NULL,
PRIMARY KEY UNIT (rgb));

CREATE TABLE TEXTURE

(t_name VARCHAR (100) NOT NULL,
type VARCHAR (100) NOT NULL,
PRIMARY KEY UNIT (t_name));

CREATE TABLE GEOMETRY

(g_id INT NOT NULL,
With_nominal DECIMAL (10,5) NOT NULL,
Length_nominal DECIMAL (10,5) NOT NULL,
Height_nominal DECIMAL (10,5) NOT NULL,
Width_real DECIMAL (10,5) NOT NULL,
Length_real DECIMAL (10,5) NOT NULL,
Height_real DECIMAL (10,5) NOT NULL,
Acceptable_width_tolerance DECIMAL (10,5) NULL,
Acceptable_length_tolerance DECIMAL (10,5) NULL,
Acceptable_height_tolerance DECIMAL (10,5) NULL,
Num_cent_cores DECIMAL (10,5) NOT NULL,
Outer_web_thick_front DECIMAL (10,5) NOT NULL,
Outer_web_thick_back DECIMAL (10,5) NOT NULL,
Outer_web_thick_right DECIMAL (10,5) NOT NULL,
Outer_web_thick_left DECIMAL (10,5) NOT NULL,
inner_web_thick DECIMAL (10,5) NULL,
core_width DECIMAL (10,5) NULL,
core_lenght DECIMAL (10,5) NULL,
Side_core_width_right DECIMAL (10,5) NULL,
Side_core_width_left DECIMAL (10,5) NULL,
Side_extrude_width_right DECIMAL (10,5) NULL,
Side_extrude_width_left DECIMAL (10,5) NULL,
Side_extrude_width_left DECIMAL (10,5) NULL,
outer_corner_radius DECIMAL (10,5) NULL,
inner_corner_radius DECIMAL (10,5) NULL,

inner_angle DECIMAL (10,5) NULL,
PRIMARY KEY UNIT (g_id));

9. Appendix D: Masonry Unit Database Webinar (29 August 2014)





BIM-M

**Building Information Modeling
for Masonry**

Implementing the Masonry Unit Database

29 August 2014

Report on Project 1: Masonry Unit Model Database

Georgia Tech Team:

Russell Gentry, School of Architecture

Chuck Eastman, Director, GT DBL

Shani Sharif, PhD Student, School of Architecture

Tyler Witthuhn, now with PES Engineers

Jeff Elder, Interstate Brick, Project Manager

David Biggs
BIM-M
Coordinator

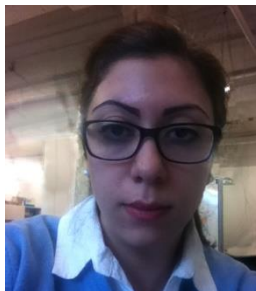

Outline

What is the Masonry Unit Model Database?

Why do We Need the Database

A Review of MUD Stakeholders

Under the Hood: The Structure of the MUD

Trial Implementation of the MUD

Critical Review by Masonry Suppliers

Wrapup

BIM-M Goal

Create Marketing Program to Compete with Concrete, Steel, Glass and Wood Structures

Create Multi-Dimensional Software Programs to Aid Design and Construction of Masonry Systems for Archs & Engineers/ Masons/ and Contractors.

Reduce Scope/ Schedule/ Budget

Develop Industry Database to Manage Data

What
Goes into
the
Model?

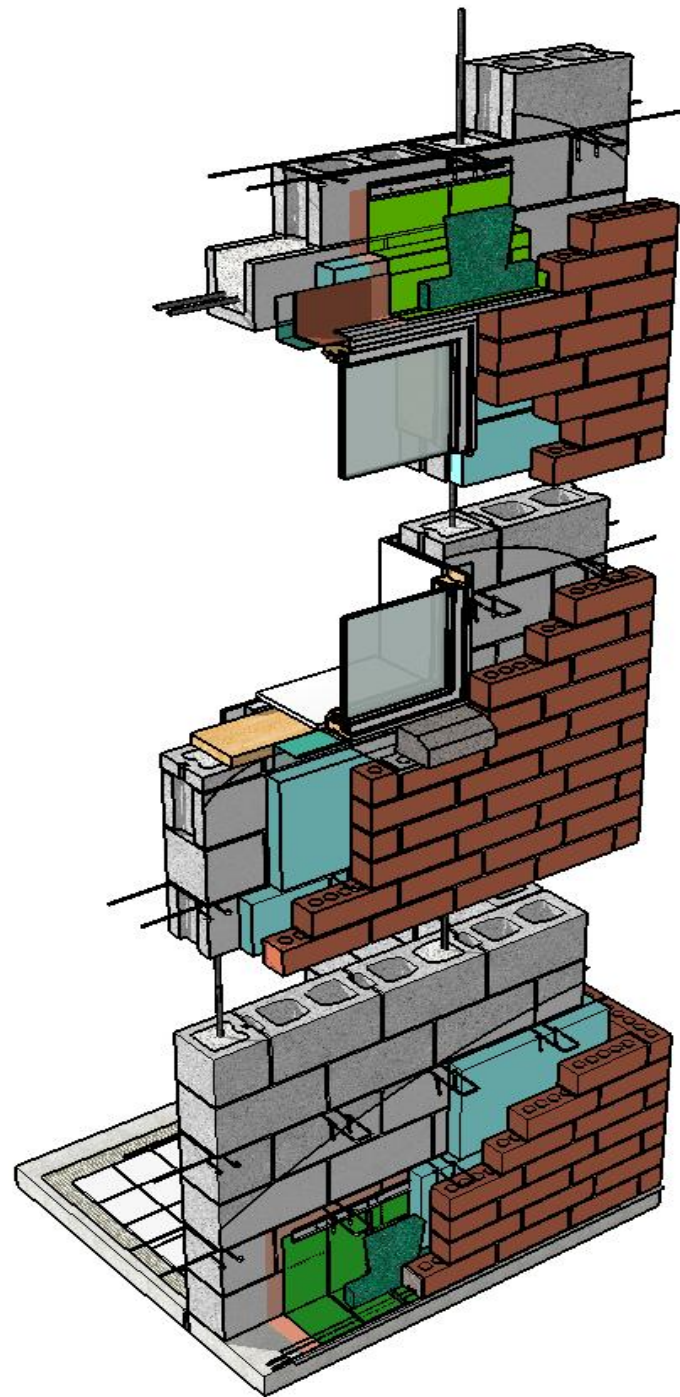

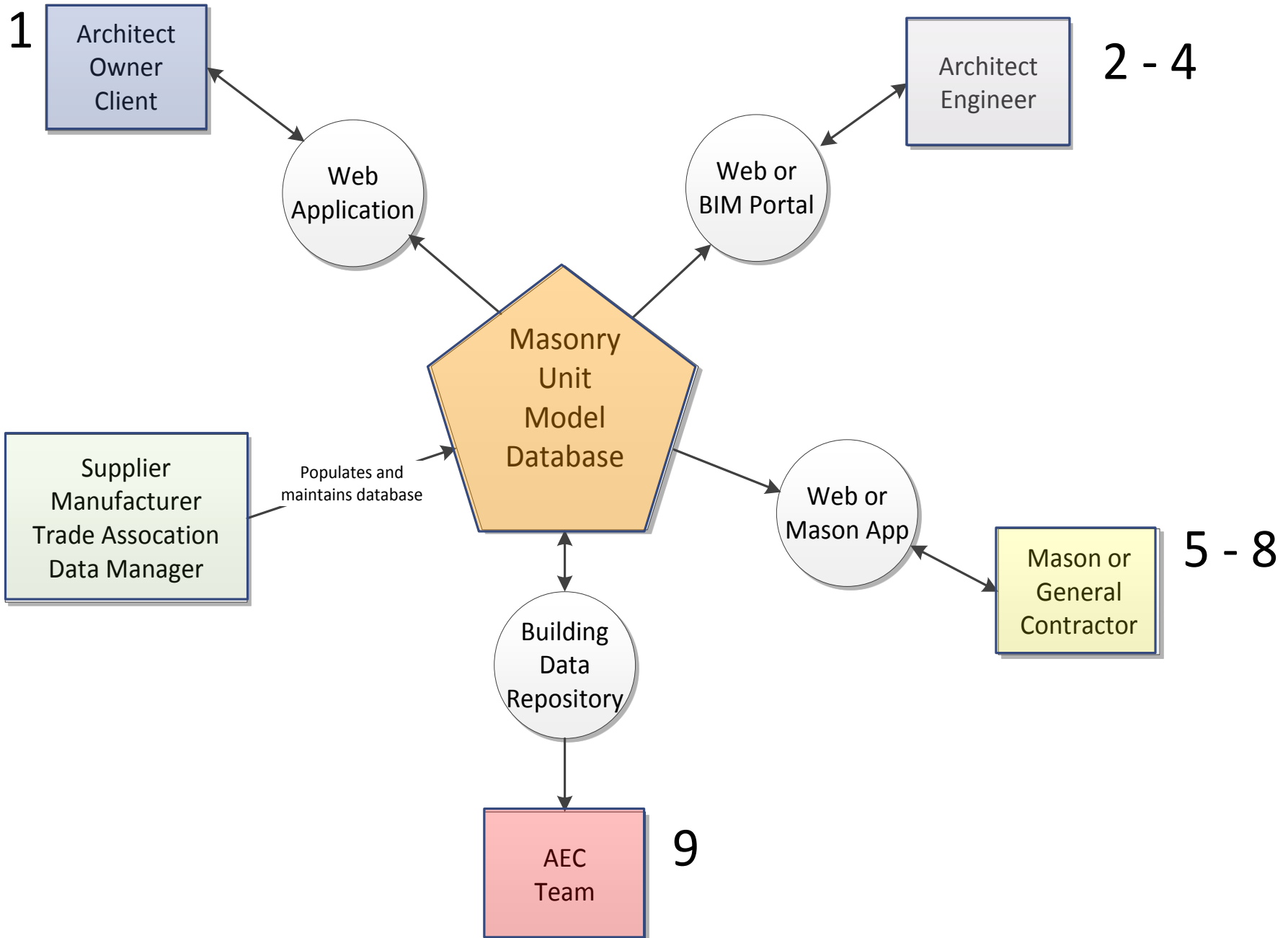

Masonry Materials



The Database

A multi-Level Database containing all pertinent unit data to build a structure.

Clay Brick Sizes	Name	3-D Shape DWG	Regional	Product Drawing	Width	Height	Length	Mortar Joint Thickness	Color	Density	Wt	IRA	Efflorescence	U-Value	R-Value	Solar Reflective Index	Weathering Resistance	ASTM	Type	Void Percent max	Void Percent Min	Traffic Resistance	Compressive Strength	FM	Cell Area	Fire Rating	Tolerance	Textures	Test Method	Flexible Base	Rigid Base	Available with Lugs	Weep Spacing	Wall Ties	Deflection Limits	CSI Format Number	ANSI STD	Coef. of thermal expansion	Modulus of Elasticity Em	Modulus of Rigidity Ev	Coefficient of Creep	Noise Reduction Coefficient	Sound Transmission Class	Fire Rating hours
				dwg.pdf	inches	inches	inches	inches	pcf		lbs	gm/30 sa-in	yes/mon		%	%	Class / Grade		%	%	Type	psi	psi	sq.in	hr	Type	Varied	ASTM	Y/N, NA	Y/N, NA	Regional	In	Y/N	Y/N	0.04		In/in/deg F	psi	psi	per psi	NRC	STC	Hours	
2-1/4 Modular		N	x	4	2.25	7.625	0.375	Varies	120	per MFR	x	x	x	x	x	SW	C216	x	25	0	x	x	x	x	x	x	x	C67	NA	NA	NA	32	Y	Y	0.421.13		4.0x10 ⁻⁶	NA	NA	.7.0x10 ⁻⁷	x	x	x	
2-5/8 Modular		Y	x	3.625	2.625	7.625	0.375	Varies	120	per MFR	x	x	x	x	x	SW	C216	x	25	0	x	x	x	x	x	x	x	C67	NA	NA	NA	32	Y	Y	0.421.13		4.0x10 ⁻⁶	NA	NA	.7.0x10 ⁻⁷	x	x	x	
2-3/4 Modular		Y	x	3.625	2.75	7.625	0.375	Varies	120	per MFR	x	x	x	x	x	SW	C216	x	25	0	x	x	x	x	x	x	x	C67	NA	NA	NA	32	Y	Y	0.421.13		4.0x10 ⁻⁶	NA	NA	.7.0x10 ⁻⁷	x	x	x	
3-5/8 Modular		Y	x	3.625	3.625	7.625	0.375	Varies	120	per MFR	x	x	x	x	x	SW	C216	x	25	0	x	x	x	x	x	x	x	C67	NA	NA	NA	32	Y	Y	0.421.13		4.0x10 ⁻⁶	NA	NA	.7.0x10 ⁻⁷	x	x	x	
Standard		Y	x	3.625	2.25	8	0.375	Varies	120	per MFR	x	x	x	x	x	SW	C216	x	25	0	x	x	x	x	x	x	x	C67	NA	NA	NA	32	Y	Y	0.421.13		4.0x10 ⁻⁶	NA	NA	.7.0x10 ⁻⁷	x	x	x	
Engineered Standard		Y	x	3.625	2.25	8	0.375	Varies	120	per MFR	x	x	x	x	x	SW	C216	x	25	0	x	x	x	x	x	x	x	C67	NA	NA	NA	32	Y	Y	0.421.13		4.0x10 ⁻⁶	NA	NA	.7.0x10 ⁻⁷	x	x	x	
8x8		N	x	3.625	7.625	7.625	0.375	Varies	120	per MFR	x	x	x	x	x	SW	C216	x	25	0	x	x	x	x	x	x	x	C67	NA	NA	NA	32	Y	Y	0.421.13		4.0x10 ⁻⁶	NA	NA	.7.0x10 ⁻⁷	x	x	x	
Roman		N	x	3.625	1.25	11.56	0.375	Varies	121	per MFR	x	x	x	x	x	SW	C217	x	25	0	x	x	x	x	x	x	x	C68	NA	NA	NA	33	Y	Y	0.421.14		4.0x10 ⁻⁷	NA	NA	.7.0x10 ⁻⁸	x	x	x	
2-1/4 Norman		Y	x	3.625	2.25	11.56	0.375	Varies	120	per MFR	x	x	x	x	x	SW	C216	x	25	0	x	x	x	x	x	x	x	C67	NA	NA	NA	24	Y	Y	0.421.13		4.0x10 ⁻⁶	NA	NA	.7.0x10 ⁻⁷	x	x	x	
2-5/8 Norman		Y	x	3.625	2.625	11.56	0.375	Varies	120	per MFR	x	x	x	x	x	SW	C216	x	25	0	x	x	x	x	x	x	x	C67	NA	NA	NA	24	Y	Y	0.421.13		4.0x10 ⁻⁶	NA	NA	.7.0x10 ⁻⁷	x	x	x	
2-3/4 Norman		Y	x	3.625	2.75	11.56	0.375	Varies	120	per MFR	x	x	x	x	x	SW	C216	x	25	0	x	x	x	x	x	x	x	C67	NA	NA	NA	24	Y	Y	0.421.13		4.0x10 ⁻⁶	NA	NA	.7.0x10 ⁻⁷	x	x	x	
Utility		N	x	3.625	3.625	11.56	0.375	Varies	120	per MFR	x	x	x	x	x	SW	C216	x	25	0	x	x	x	x	x	x	x	C67	NA	NA	NA	24	Y	Y	0.421.13		4.0x10 ⁻⁶	NA	NA	.7.0x10 ⁻⁷	x	x	x	
2.25 Ambassador		Y	x	3.563	2.25	15.56	0.438	Varies	120	per MFR	x	x	x	x	x	SW	C216	x	25	0	x	x	x	x	x	x	x	C67	NA	NA	NA	32	Y	Y	0.421.13		4.0x10 ⁻⁶	NA	NA	.7.0x10 ⁻⁷	x	x	x	
2.625 Ambassador		Y	x	3.563	2.625	15.56	0.438	Varies	120	per MFR	x	x	x	x	x	SW	C216	x	25	0	x	x	x	x	x	x	x	C67	NA	NA	NA	32	Y	Y	0.421.13		4.0x10 ⁻⁶	NA	NA	.7.0x10 ⁻⁷	x	x	x	
2.75 Ambassador		Y	x	3.563	2.75	15.56	0.438	Varies	120	per MFR	x	x	x	x	x	SW	C216	x	25	0	x	x	x	x	x	x	x	C67	NA	NA	NA	32	Y	Y	0.421.13		4.0x10 ⁻⁶	NA	NA	.7.0x10 ⁻⁷	x	x	x	
Monarch		Y	x	3.563	3.625	15.56	0.438	Varies	120	per MFR	x	x	x	x	x	SW	C216	x	25	0	x	x	x	x	x	x	x	C67	NA	NA	NA	32	Y	Y	0.421.13		4.0x10 ⁻⁶	NA	NA	.7.0x10 ⁻⁷	x	x	x	
Obi Monarch		Y	x	3.563	7.625	15.56	0.438	Varies	120	per MFR	x	x	x	x	x	SW	C216	x	25	0	x	x	x	x	x	x	x	C67	NA	NA	NA	32	Y	Y	0.421.13		4.0x10 ⁻⁶	NA	NA	.7.0x10 ⁻⁷	x	x	x	
King		Y	x	3	2.625	9.625	0.375	Varies	120	per MFR	x	x	x	x	x	SW	C216	x	25	0	x	x	x	x	x	x	x	C67	NA	NA	NA	32	Y	Y	0.421.13		4.0x10 ⁻⁶	NA	NA	.7.0x10 ⁻⁷	x	x	x	
Queen		Y	x	3	2.625	8.625	0.375	Varies	120	per MFR	x	x	x	x	x	SW	C216	x	25	0	x	x	x	x	x	x	x	C67	NA	NA	NA	32	Y	Y	0.421.13		4.0x10 ⁻⁶	NA	NA	.7.0x10 ⁻⁷	x	x	x	

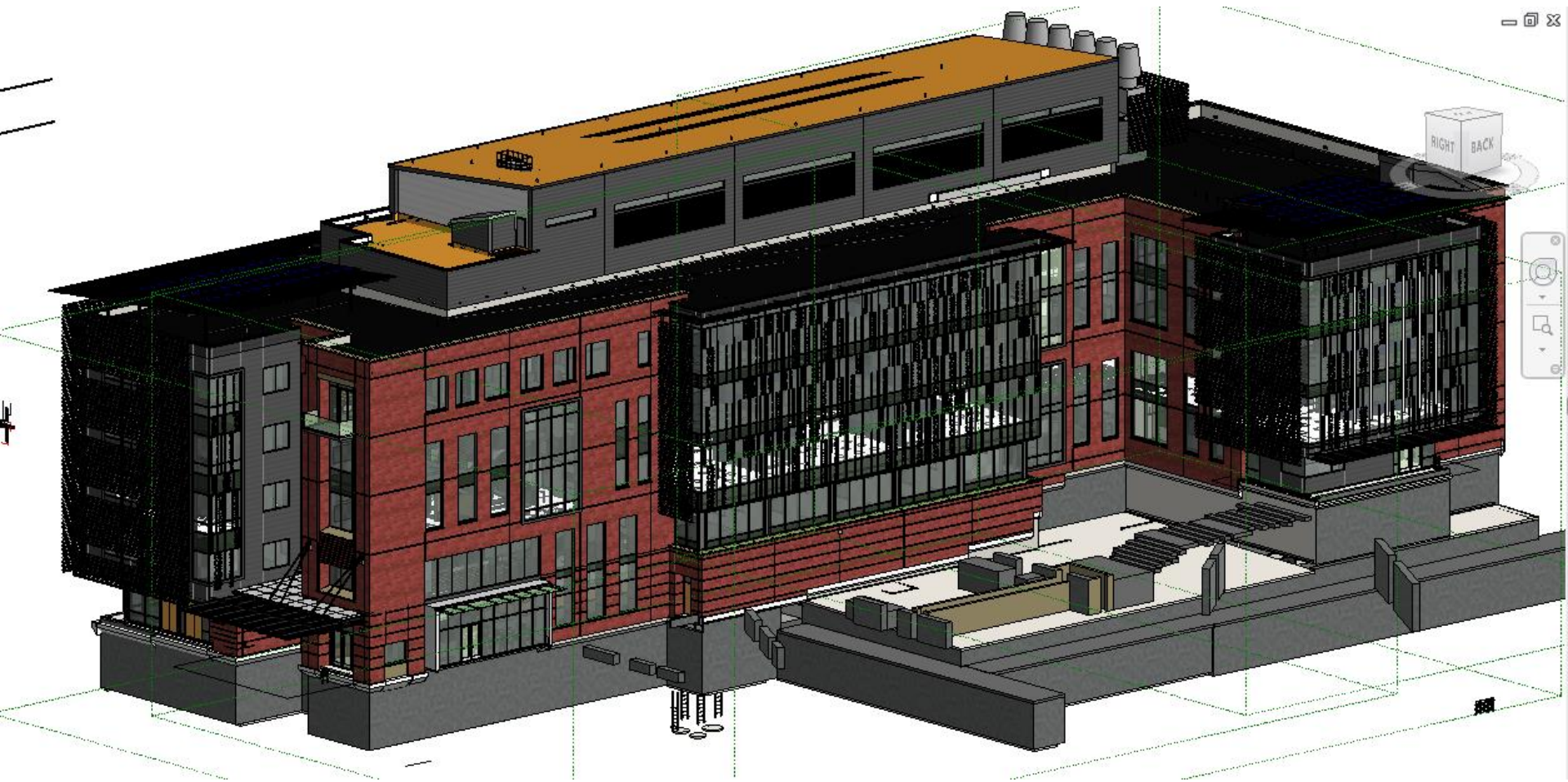

Masonry unit data is necessary for input into building BIM models.

Why do we need a masonry unit database?

- Because architects, engineers and contractors want access to the geometry of masonry units to place in their BIM models – they are drawing and re-drawing the units now; we should provide it to them.
- They want this geometry in a wide range of formats but modeled in a reliable way
- Because the automation of BIM model creation requires that the data be available in a standardized format – and current models produced by the industry do not follow any standard.
- Analysis tools tied to BIM like structural analysis, cost analysis, energy analysis needs property information about the masonry units in the model.
- We can't build BIM models for masonry walls without the geometric information of masonry units.
- It's hard to gather and compare information about the wide range of masonry available in the marketplace today.

Who will use the Masonry Unit Database?

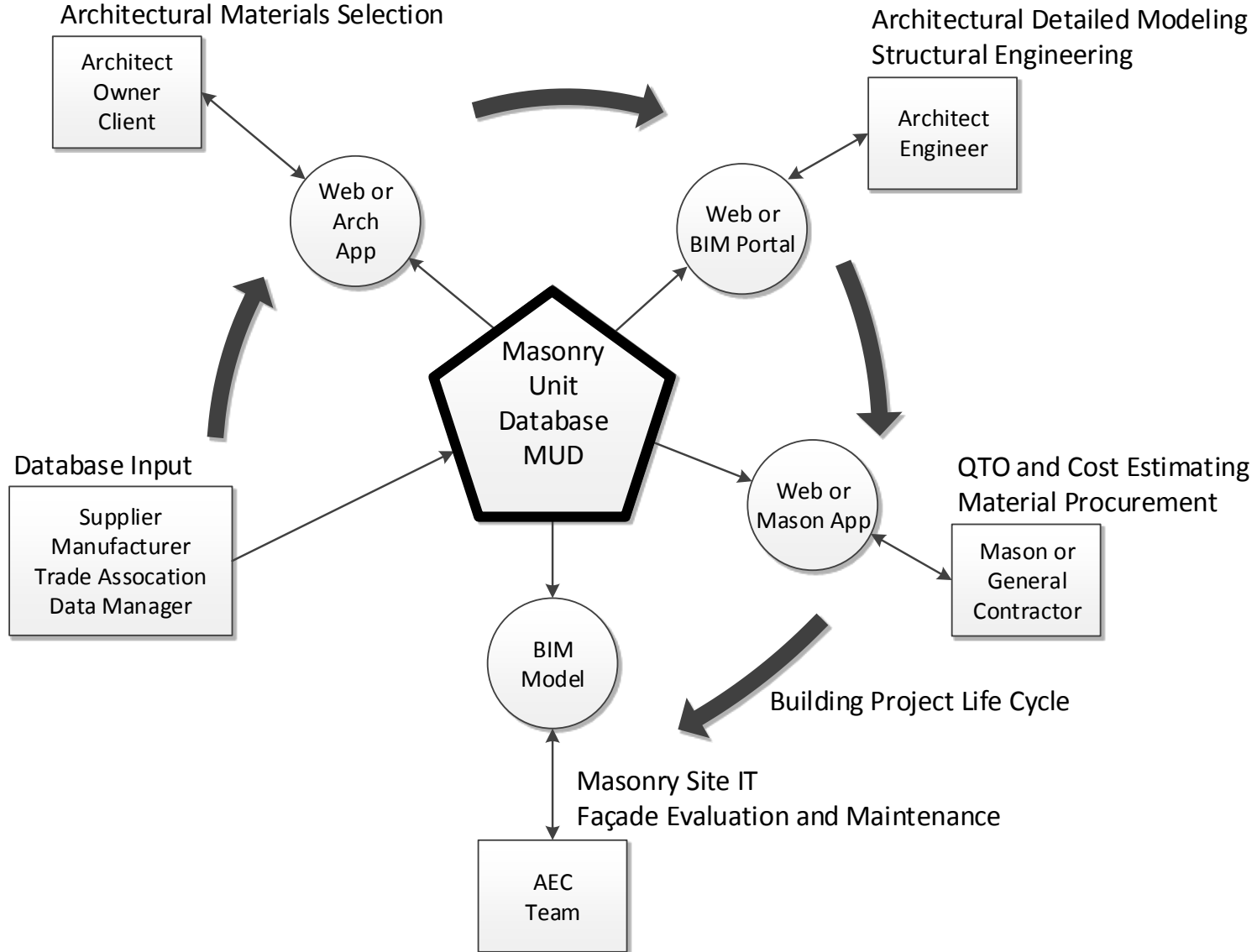

What is in the Masonry Unit Database (MUD):

- A data model to capture all of the geometric, and non-geometric information of masonry units
- Information needed to select, specify and purchase masonry units

The main entities defined in MUD are:

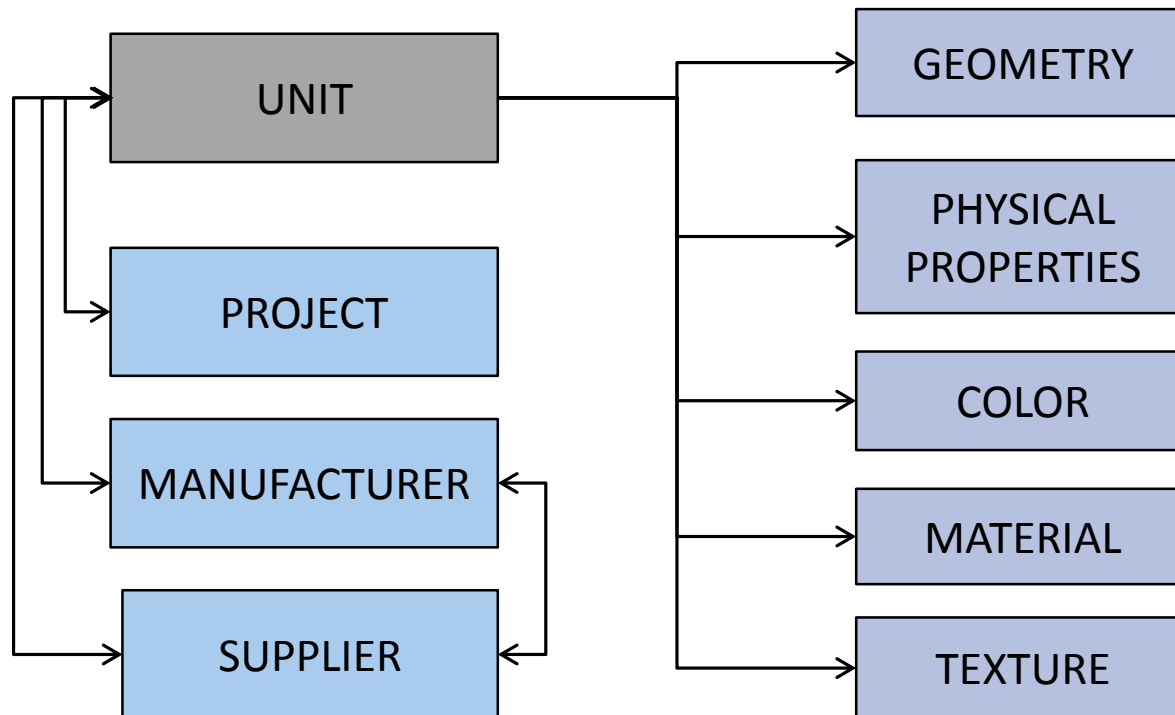

What is NOT in the Masonry Unit Database

- Availability (Stocked or Custom)
- Order Quantity
- Shipping Information

The MUD is not a back-end to an “AMAZON.COM” for masonry. It is not about e-commerce. That might be important to the industry, but that is not what we are doing.

What about price: you need to decide!

How do we know what to put in the database?

Masonry Project Workflow

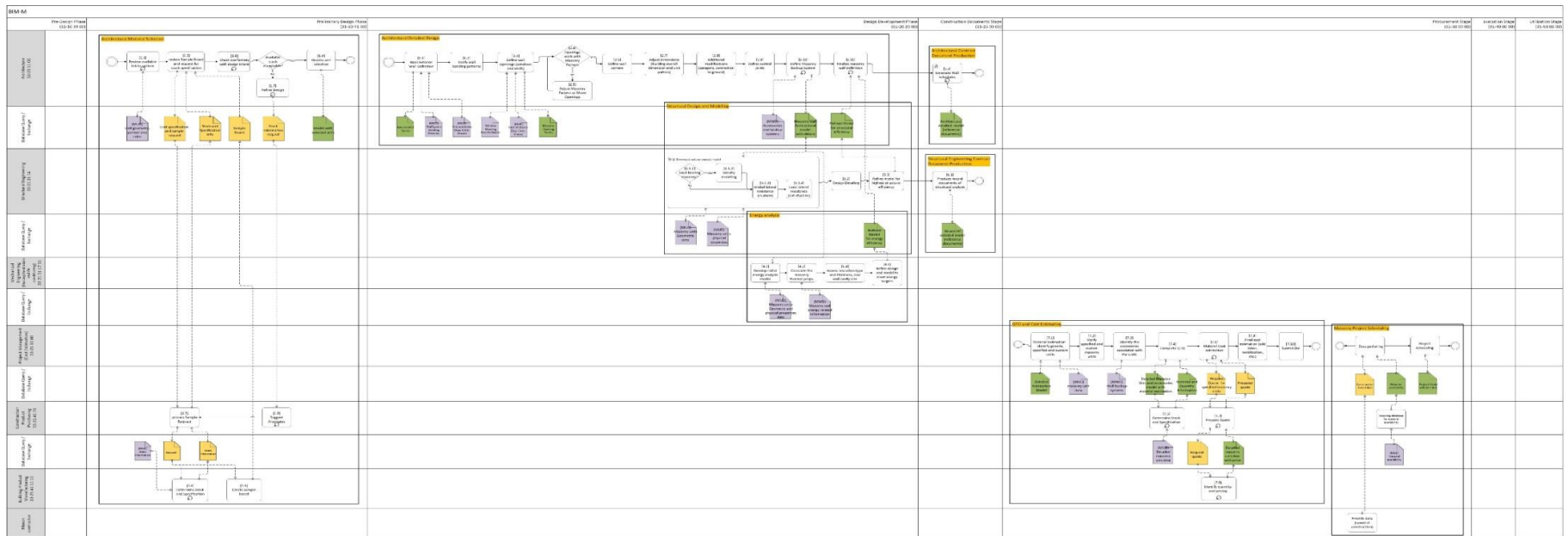
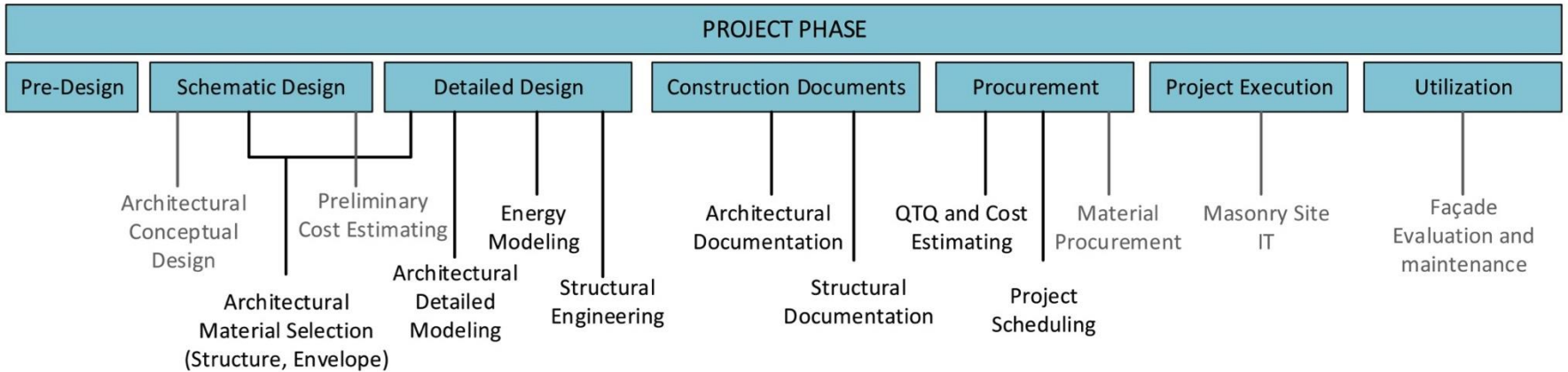

Masonry Project Workflow: Structural Modeling and Design

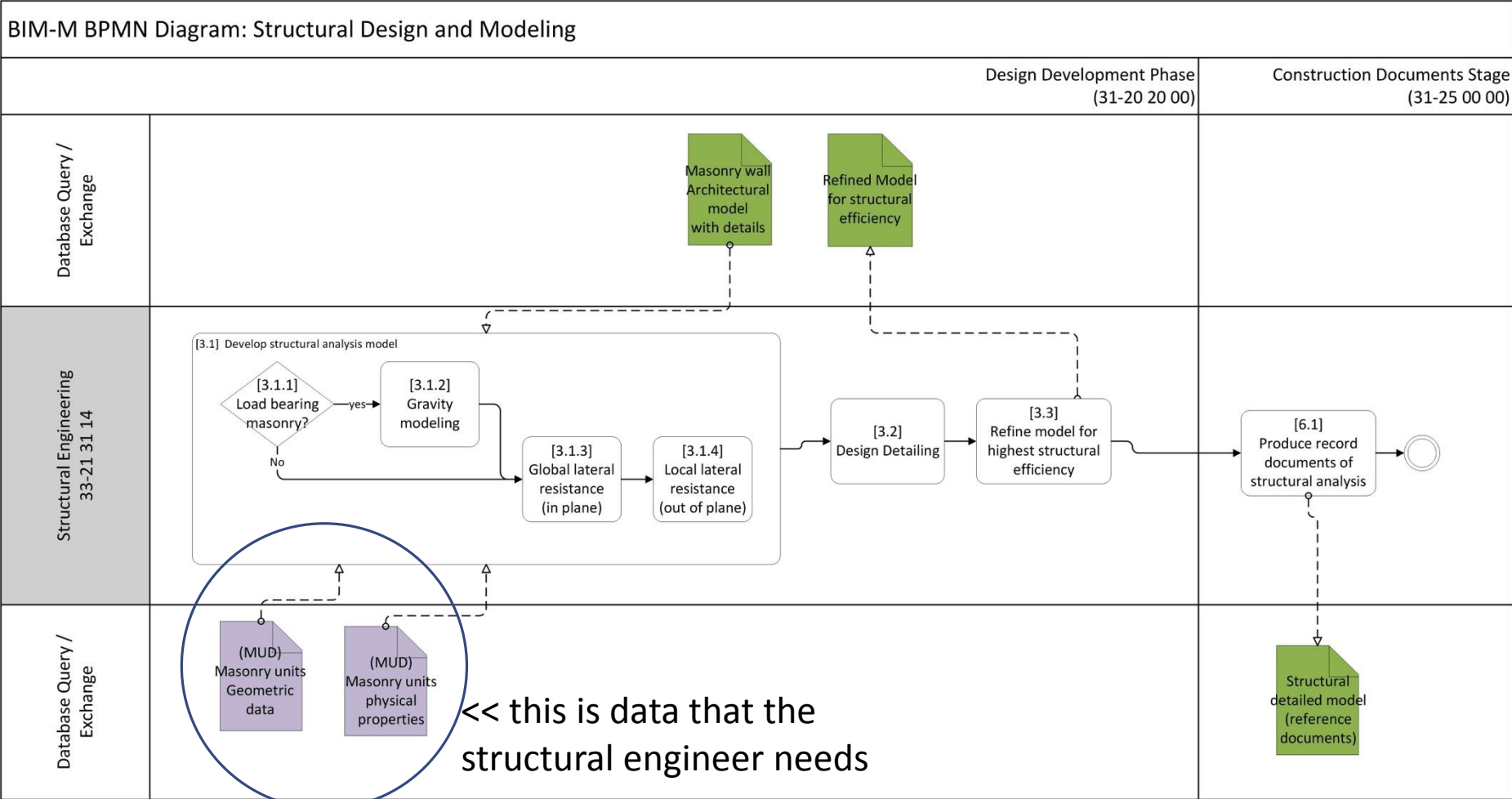

Classification of Masonry Units at the Detailed Level

➤ Concrete Masonry Units

- Nominal size
- Real size, mortar joints
- Material type
- Cores
- Texture
- Color



➤ Architectural Brick

- Veneer, not load-bearing
- Backup System
- method of manufacture
- Size
- Texture
- Color



➤ Structural Brick

- structural, hollow brick
- Clay
- Cores, reinforcing and grout

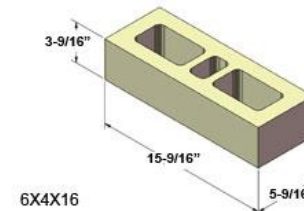

➤ Cast Stone

- custom designed units
- building accent pieces: lintels, sills, and trim parts



Masonry Unit Database (MUD)

Main entities defined in MUD:

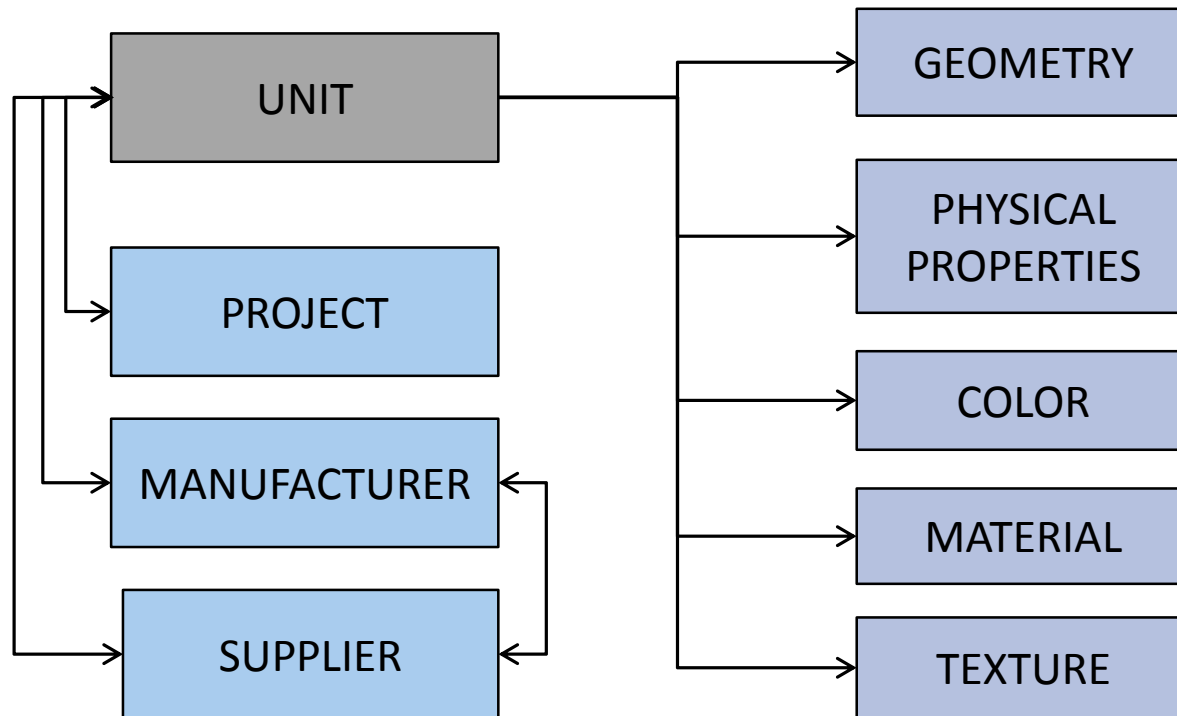

Proposed ER (Entity-Relationship) Model for MUD

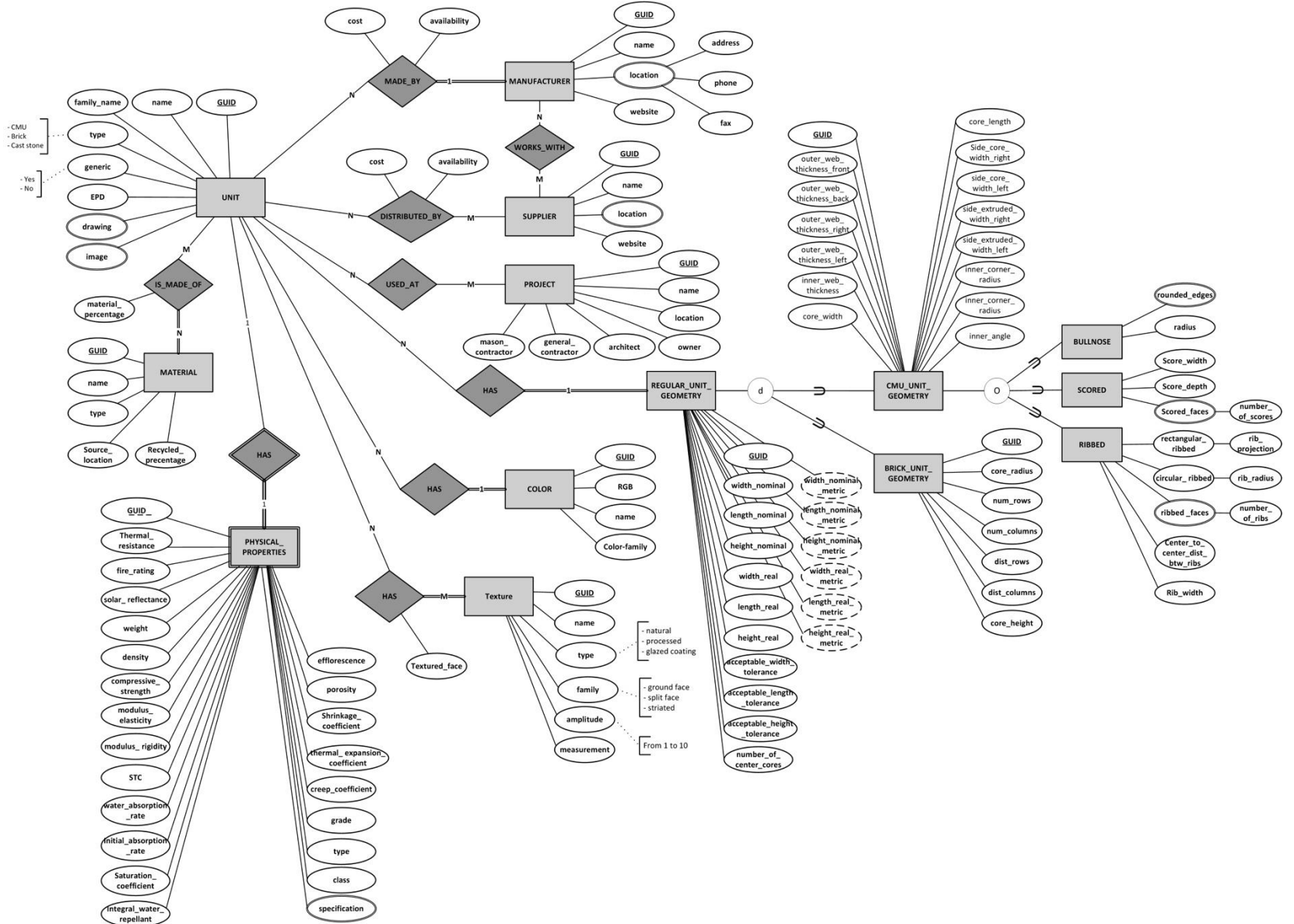

What does the MUD look like?

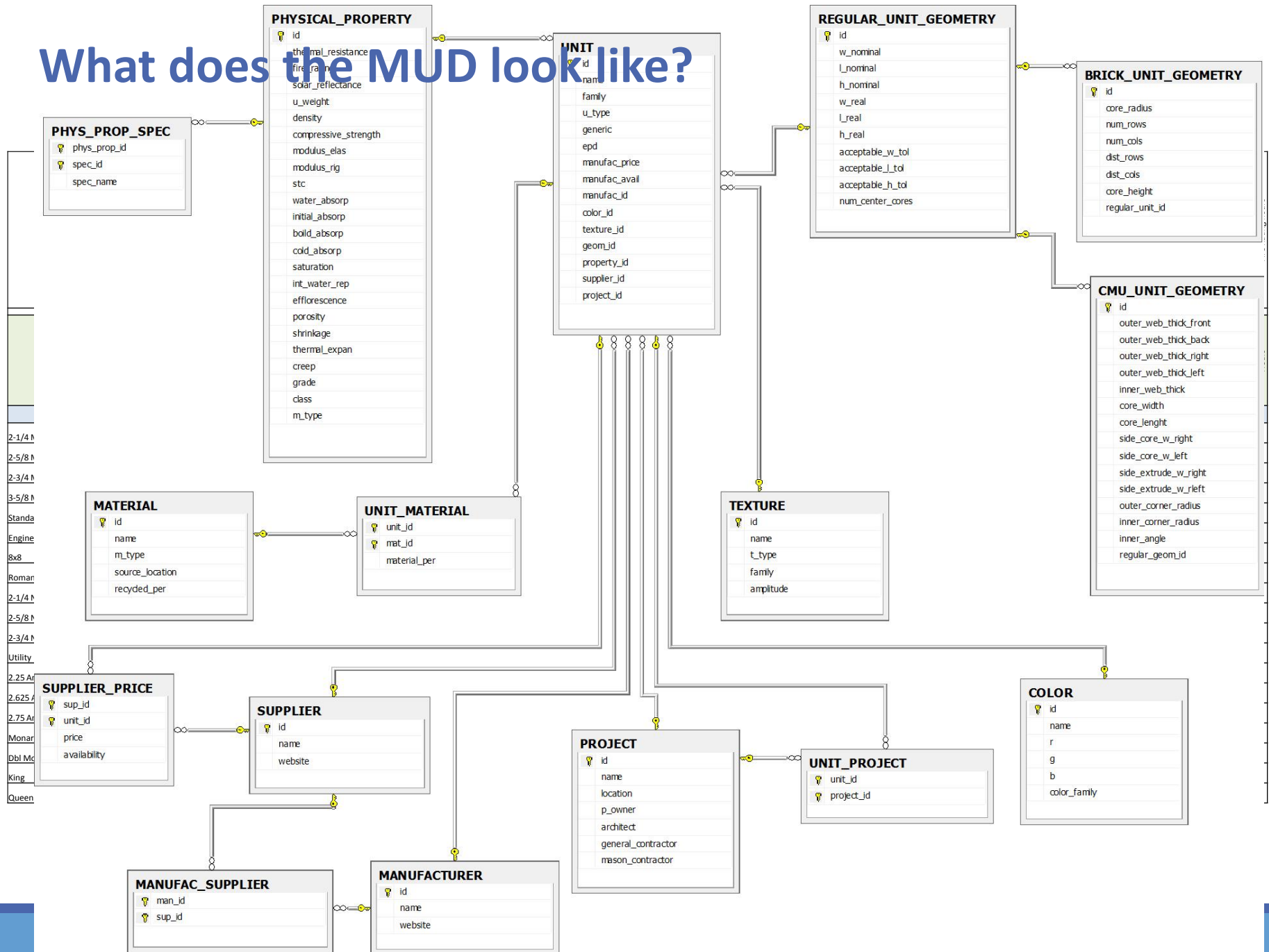

2-1/4"
2-5/8"
2-3/4"
3-5/8"
Standa
Engine
8x8
Roman
2-1/4"
2-5/8"
2-3/4"
Utility
2.25 Ar
2.625 Ar
2.75 Ar
Monar
Dbl Mc
King
Queen

Proposed ER (Entity-Relationship) Model for MUD :: UNIT Table

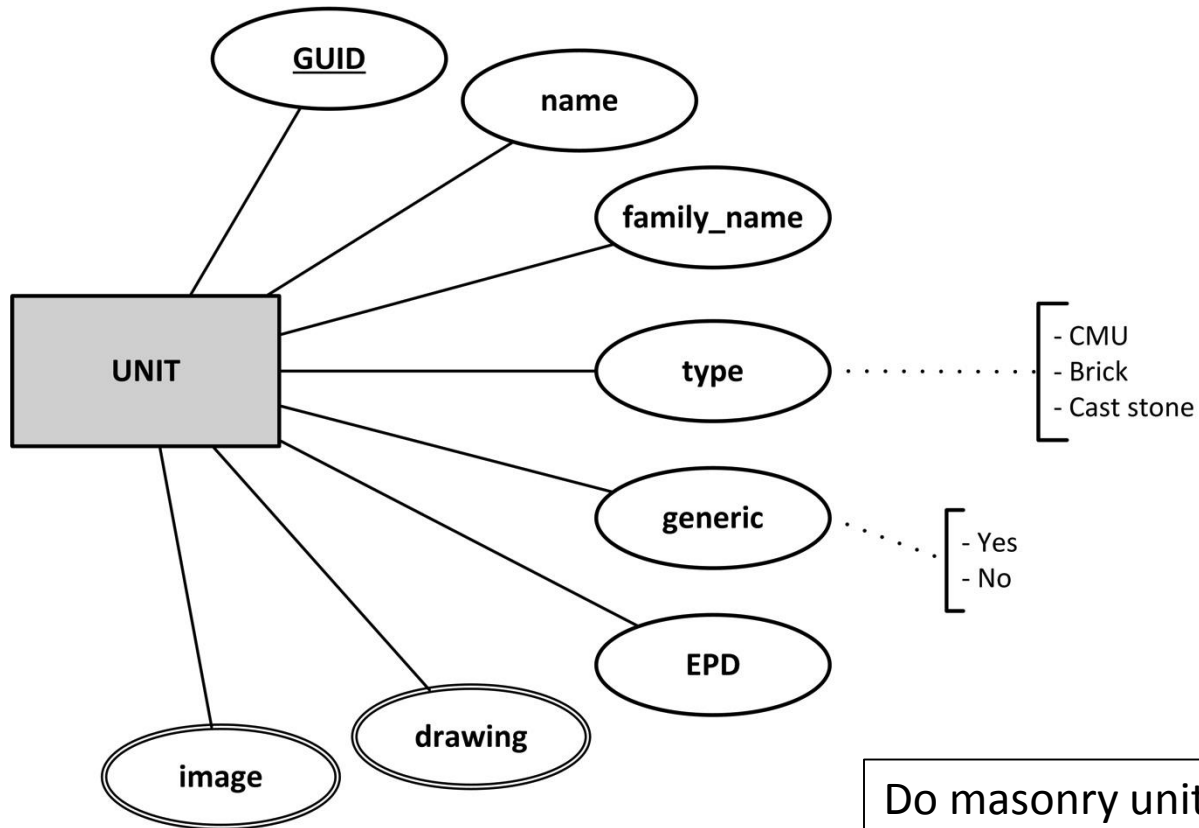

Do masonry units have unique SKUs or UPCs? If so, we need to put that here.

Proposed ER (Entity-Relationship) Model for MUD

Main entities defined for the MUD are:

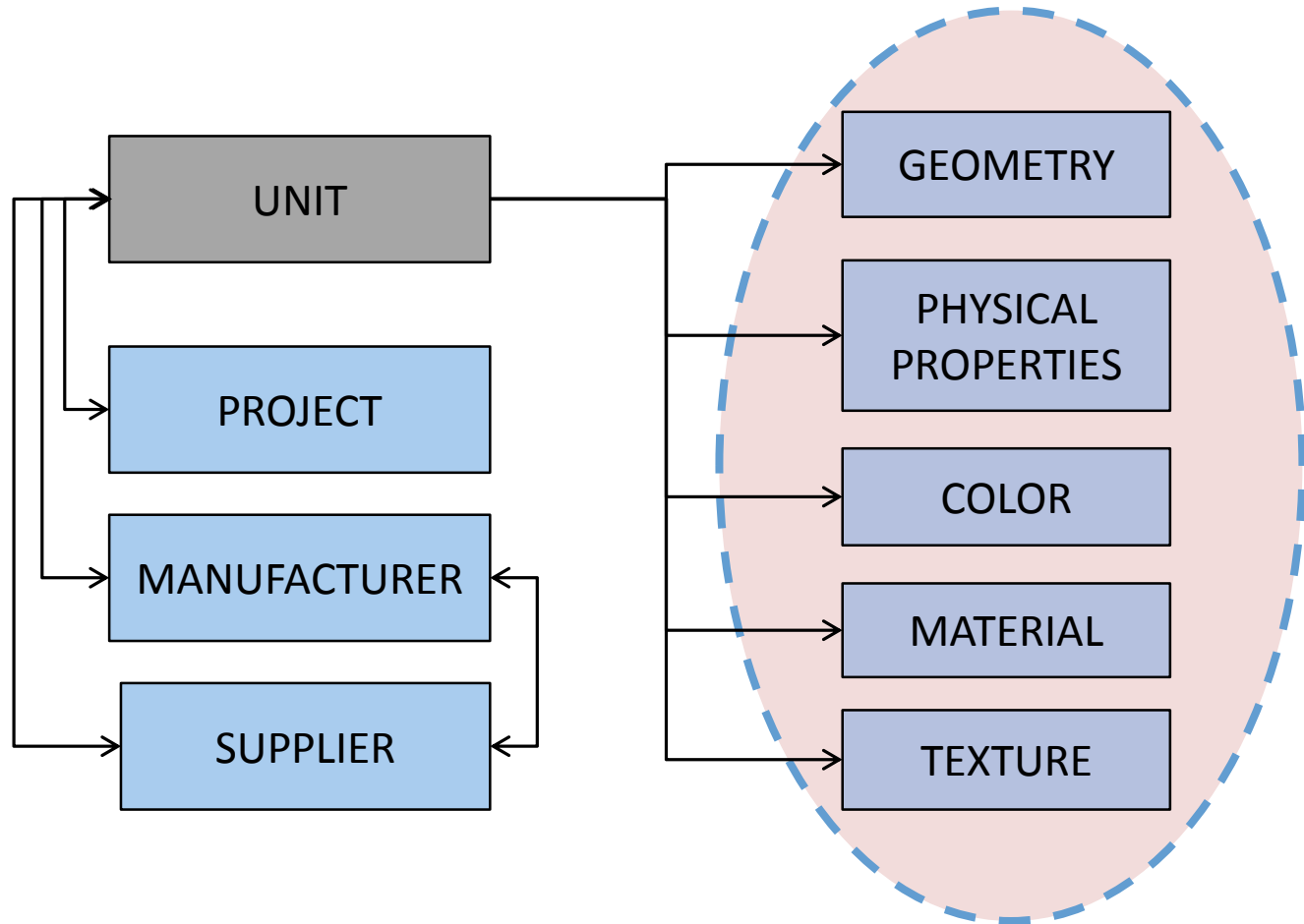

Proposed ER (Entity-Relationship) Model for MUD

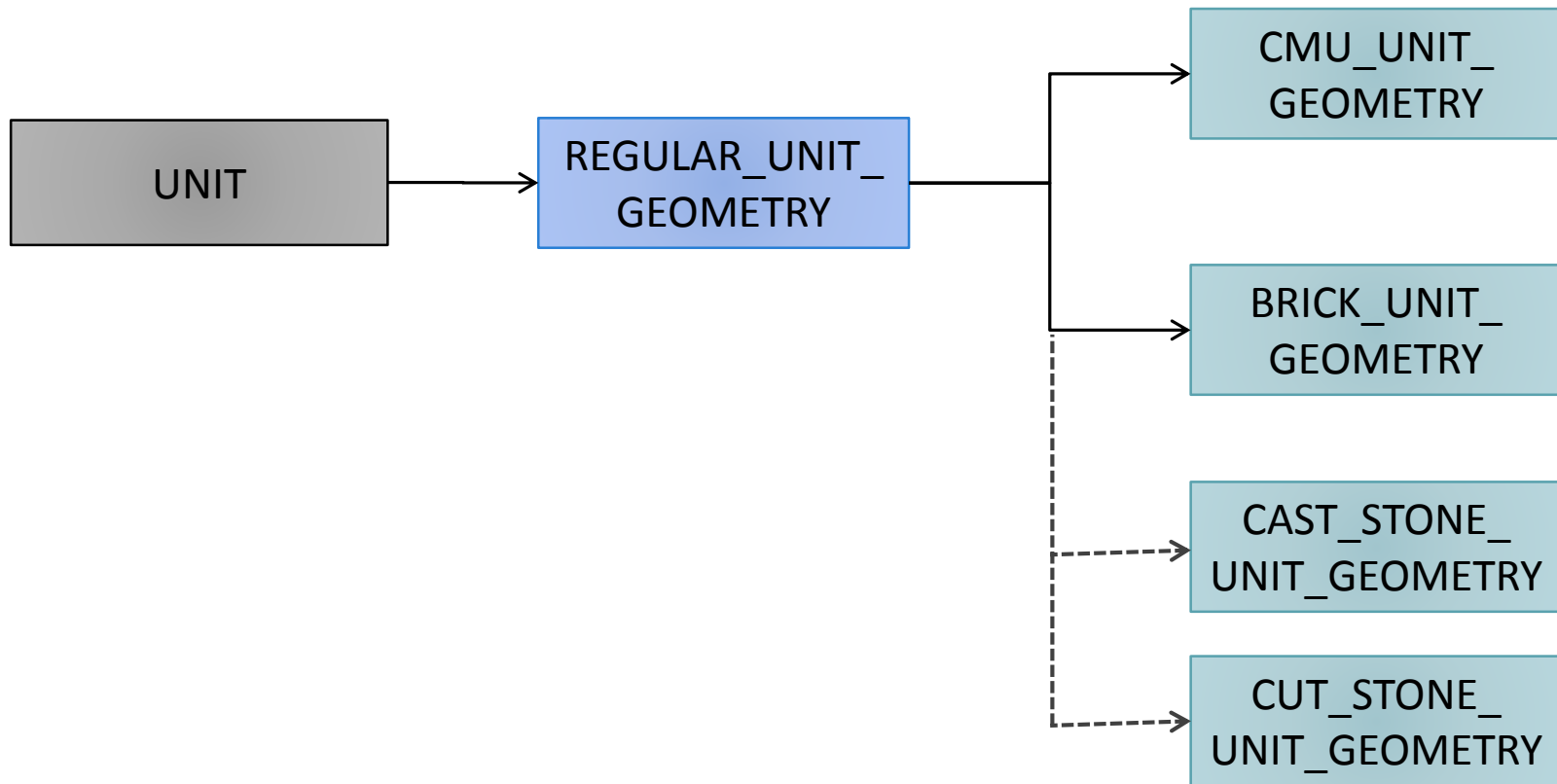

For the future . . .

Storage of Masonry Unit Geometry in the MUD

1. Regular Unit Geometry:

- described in the MUD by parametric geometry and key attributes
- most standard CMU and clay masonry
- CAD and BIM drawings generated automatically

2. Special Unit Geometry:

- may have geometric features that cannot be described parametrically, but are “close enough” to regular
- example: CMU and brick with odd core spacing or geometry

3. Custom Unit Geometry:

- too complex to store shape parametrically
- must be stored as a fully drawn shape in the MUD
- bounding box shown as L x W x H

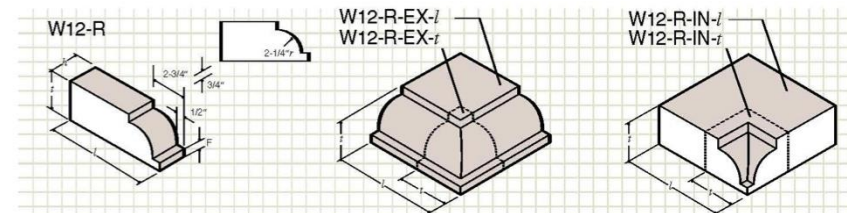
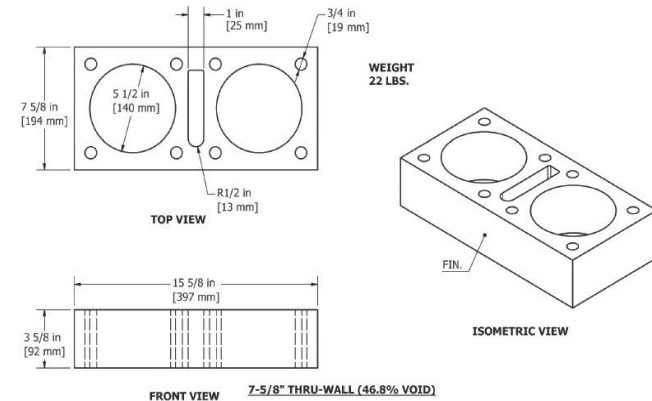
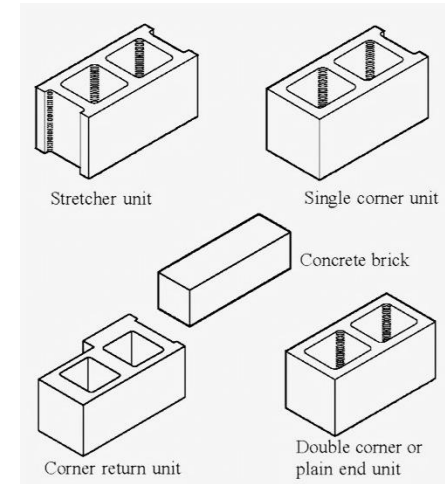

REGULAR_UNIT_GEOMETRY

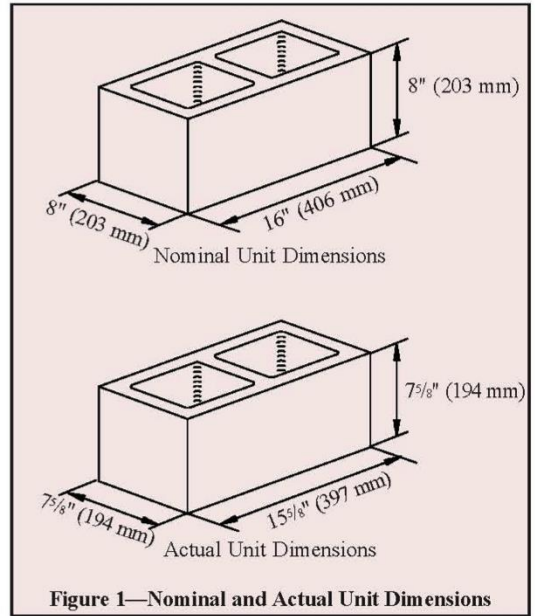
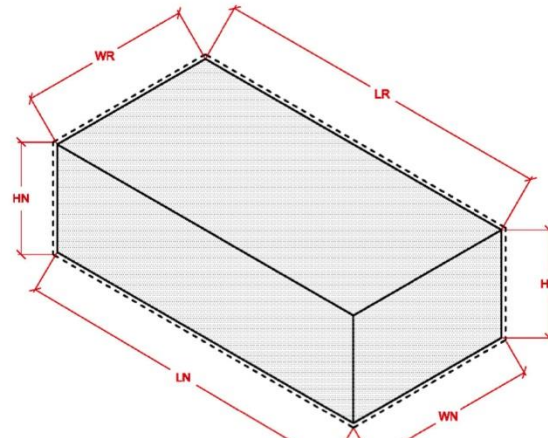
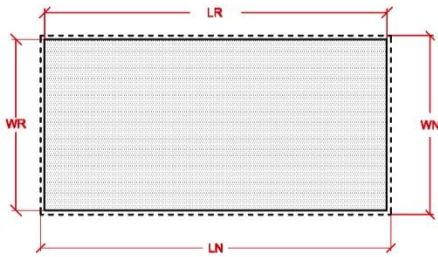
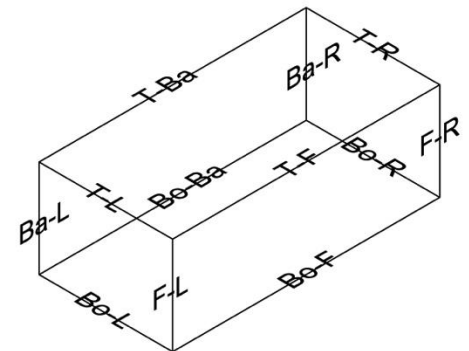
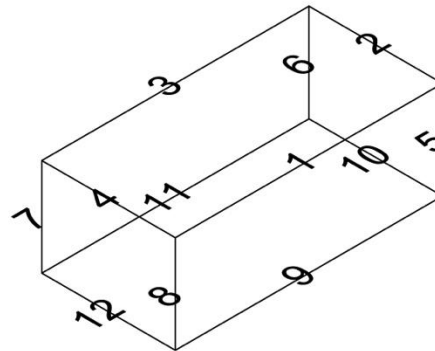
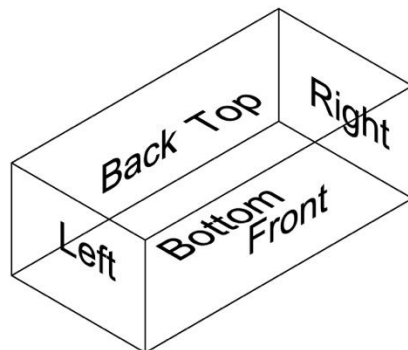
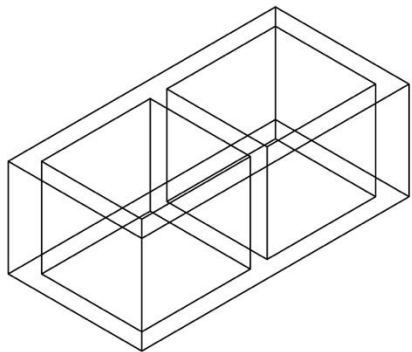
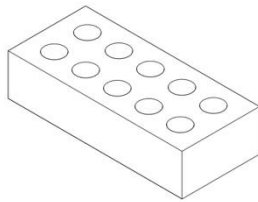
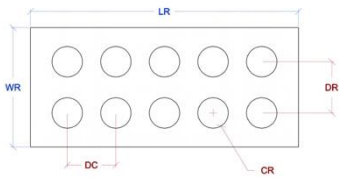
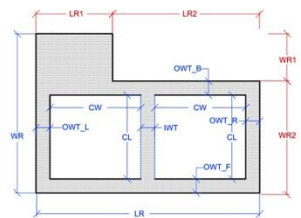
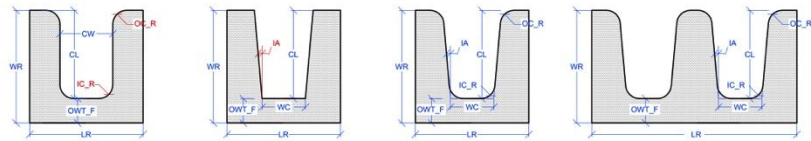
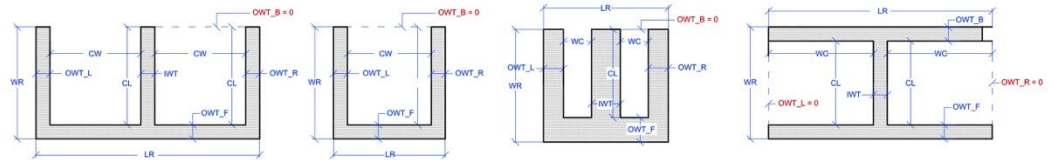
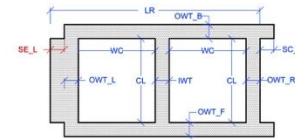
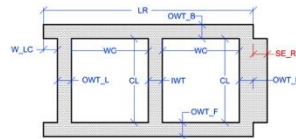
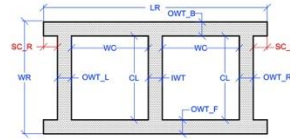
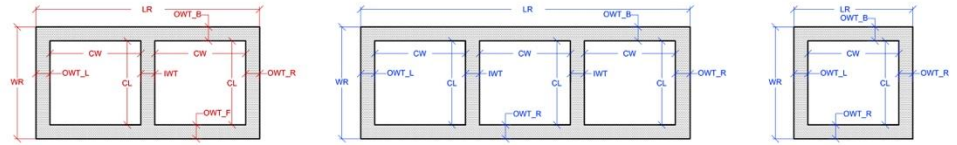

Figure 1—Nominal and Actual Unit Dimensions



CMU_UNIT_ GEOMETRY



BRICK_UNIT_ GEOMETRY

unit_ID	
unit_name	
unit-family	
WN	Width nominal
LN	Length nominal
HN	Height Nominal
WR	Width Real
WR1, WR2	L-Shape blocks
LR	Length Real
LR1, LR2	L-Shape blocks
HR	Height Real
WR_T	acceptable width tolerance
LR_T	acceptable length tolerance
HR_T	acceptable height tolerance
NC_C	Number of Center Cores

OWT_F	Outer web thickness Front
OWT_B	Outer web thickness Back
OWT_R	Outer web thickness Right
OWT_L	Outer web thickness Left
IWT	Inner Web thickness
CW	Core width
CL	Core Length
SC_R	side core - width - right
SC_L	side core- width - left
SE_R	side extruded width- right
SE_L	side extruded width- left
OC_R	Outer Corner radius
IC_R	Inner Corner radius
IA	Inner Angle

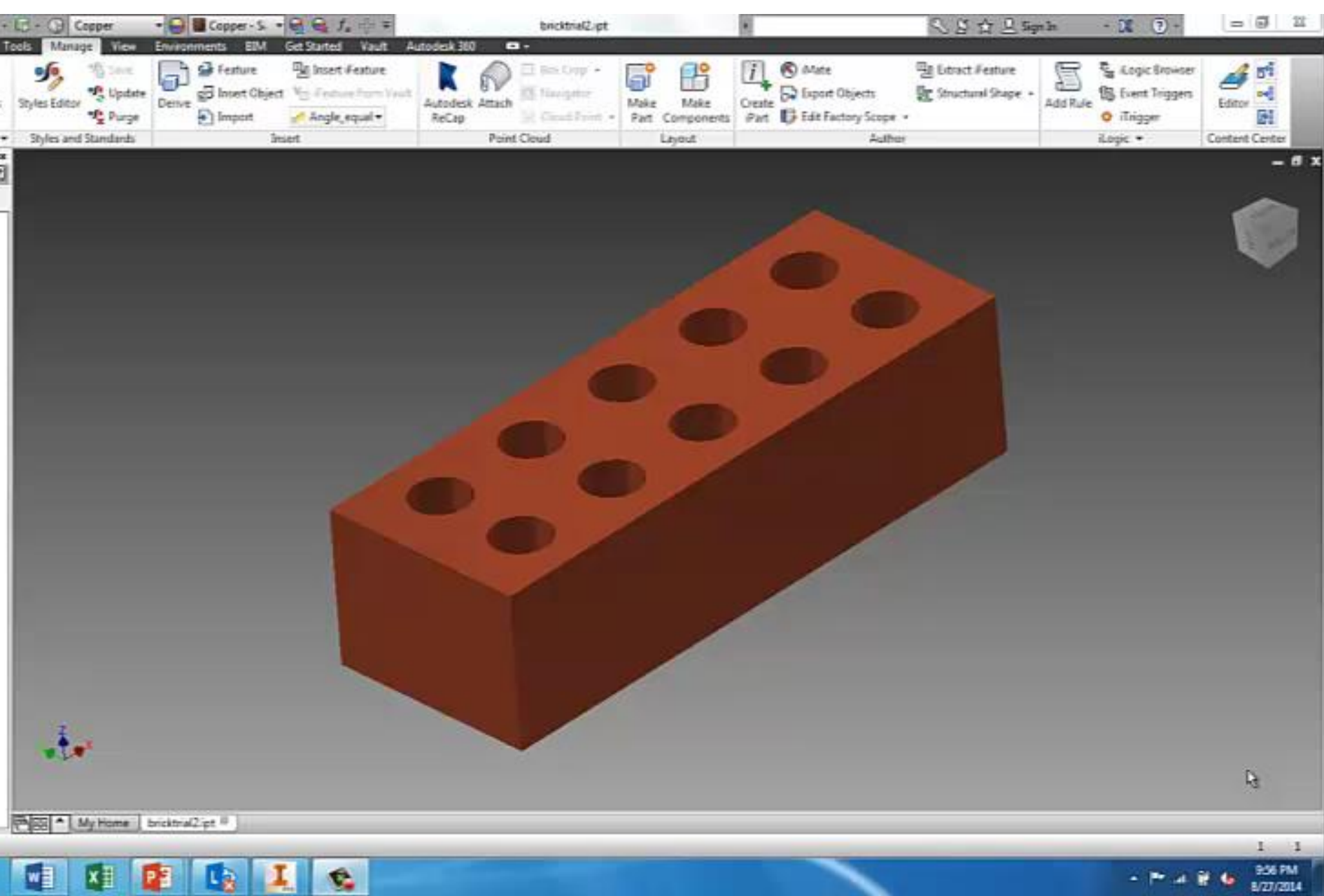

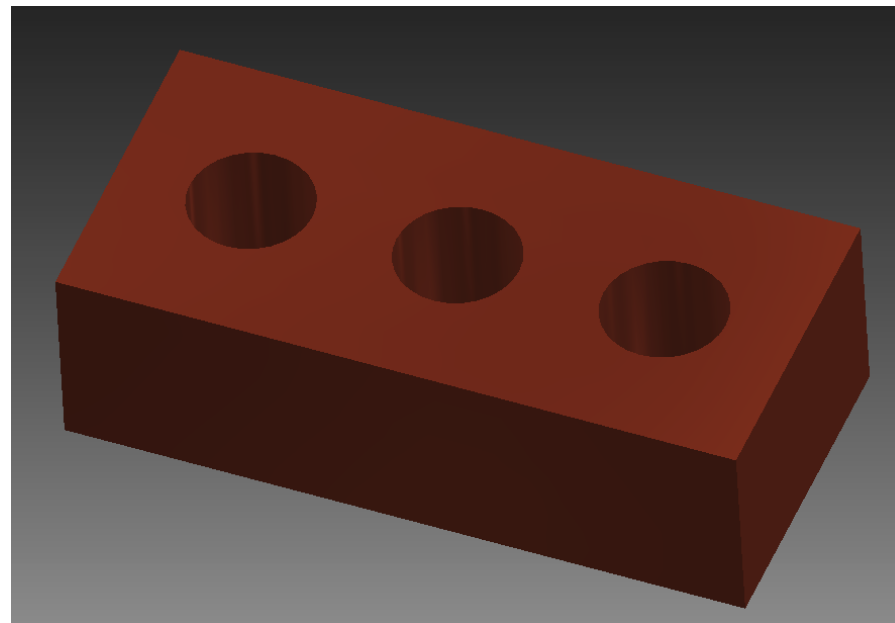

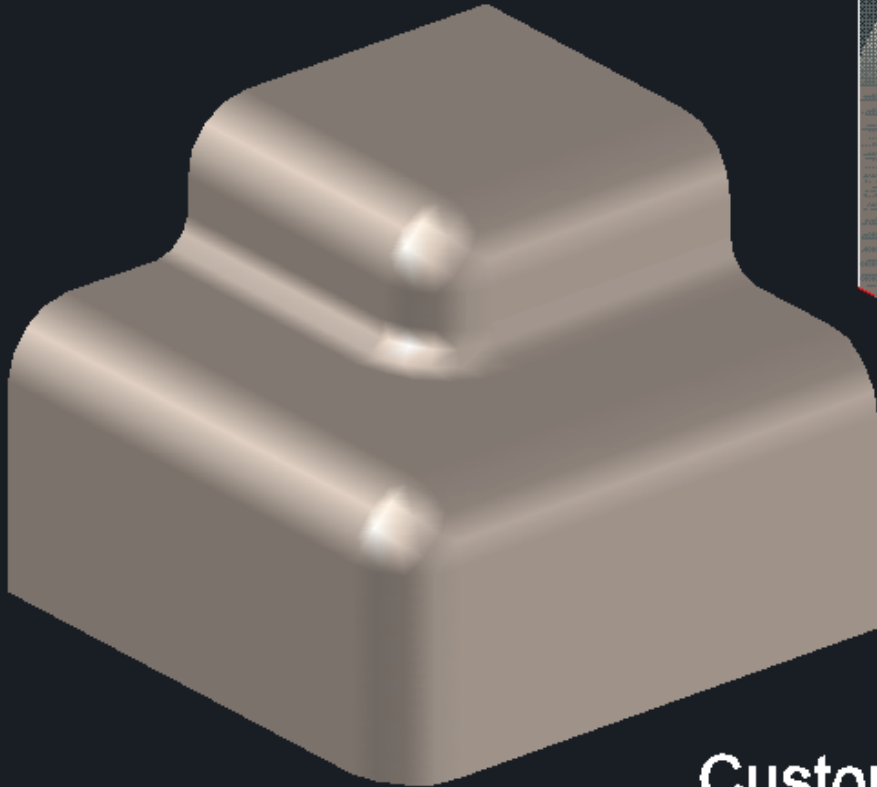

Custom Unit

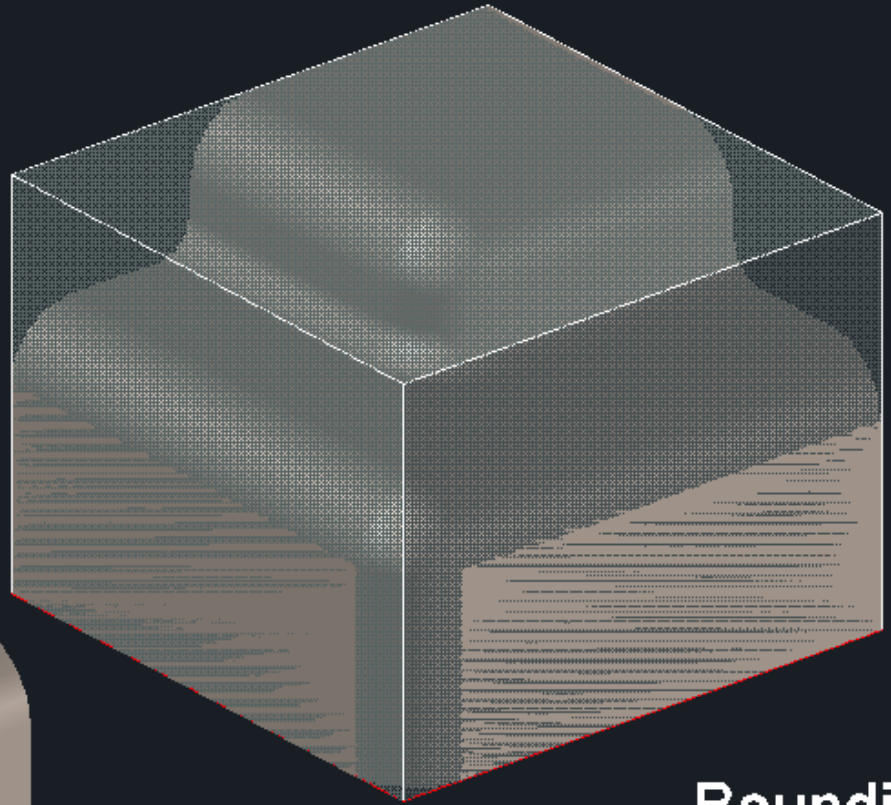

Bounding Box



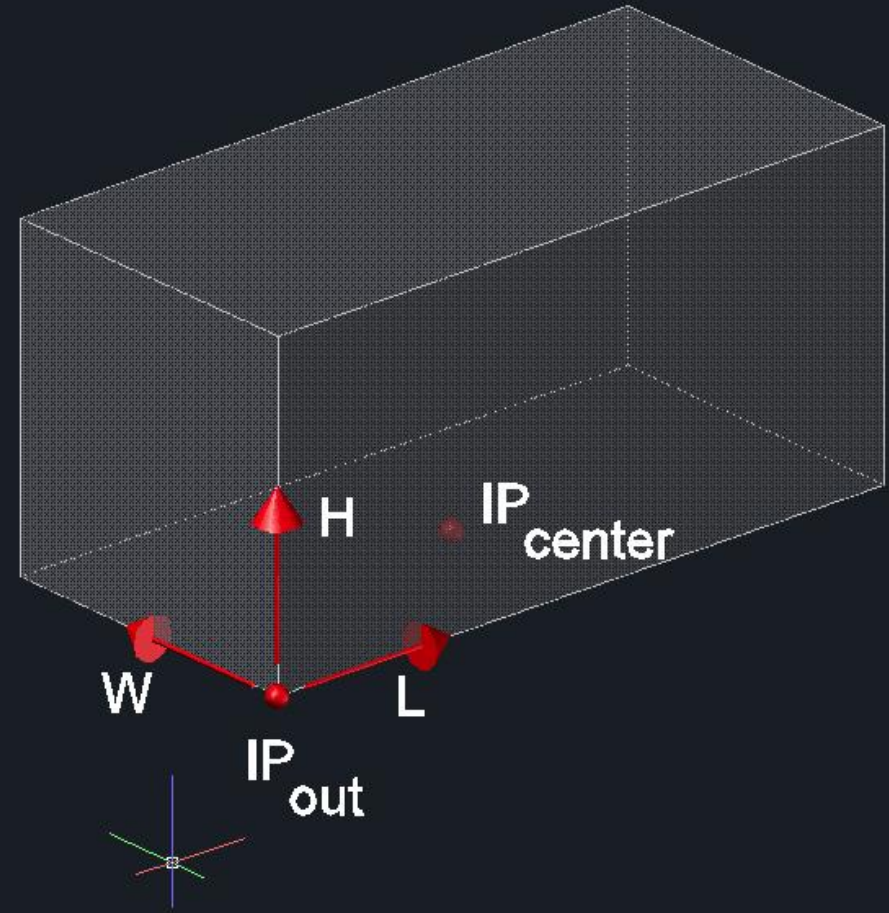
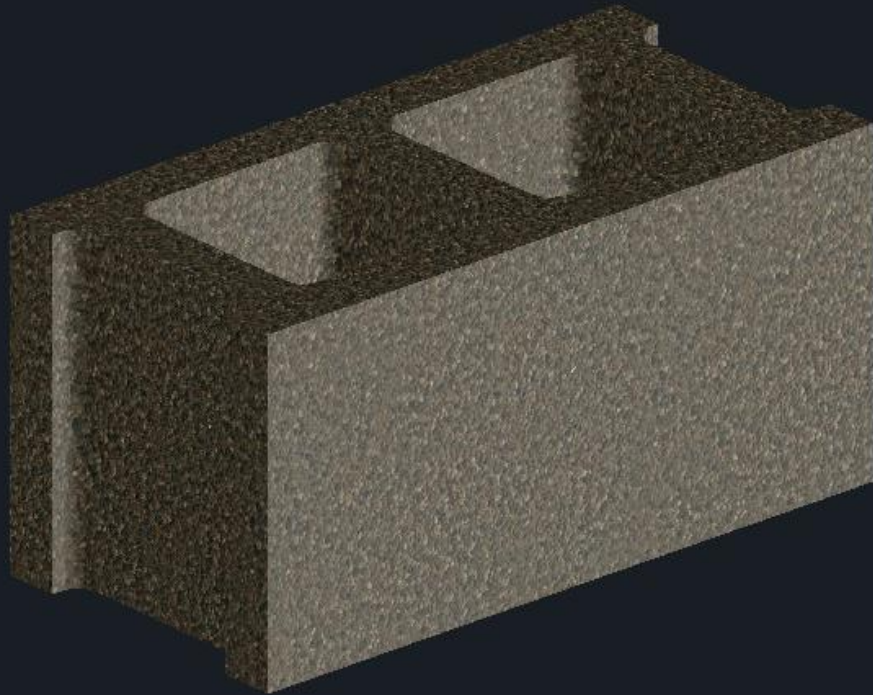

Images:

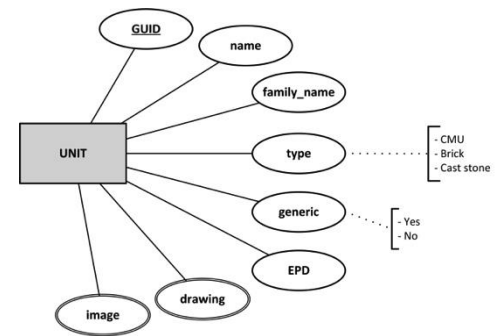

Images of production units taken in a standardized way to represent the full range of colors and textures expected for the unit. Images will be a combination of “straight on” and “axonometric” views to show the full characteristics of the units.



Masonry Geometry Export in MUD

1. 2-D DXF for CAD models – do we really need this?
2. 3-D DWG and DXF for CAD and BIM models
3. 3-D parasolid for parametric modeling software
4. RVA files for Revit
5. IFC file for Open BIM
6. Sketch-Up Component (probably a DXF is OK here)

We need some input from our stakeholder community here AND
We have to anticipate that the geometry export will be updated when the masonry wall definition is complete.

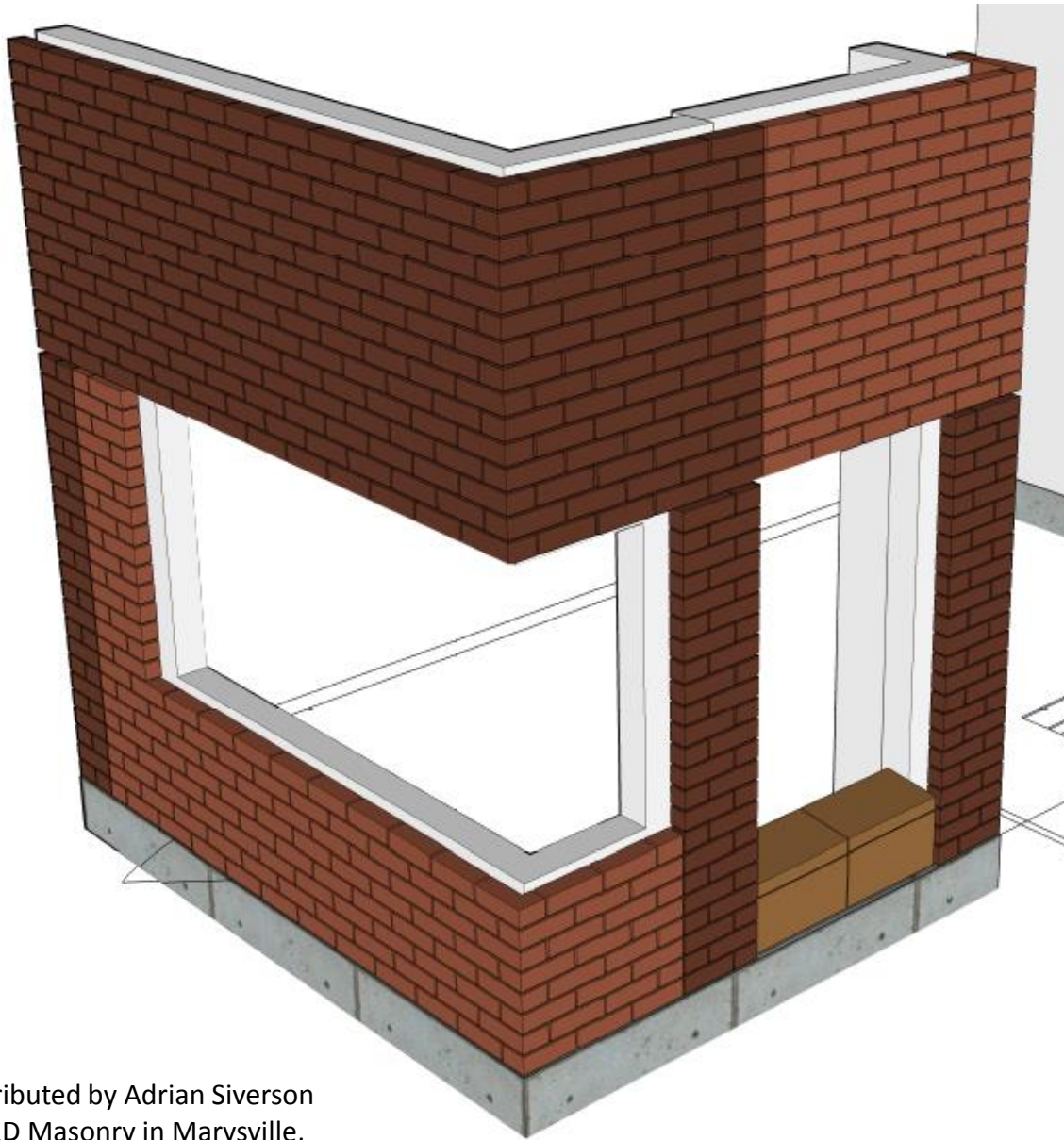

**Econ Brick Full Type 2
Rug Face**

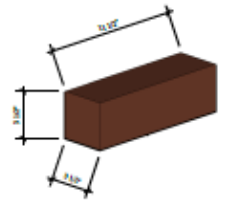

**Econ Brick Half Type 2
Rug Face**

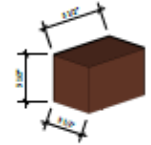

**Econ Brick Corner Type 2
Rug Face**

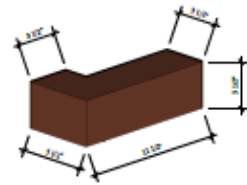

**Econ Brick Full Type 1
Smooth Face**

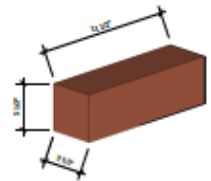

**Econ Brick Half Type 1
Smooth Face**

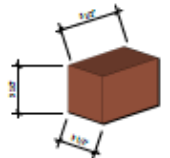

**Econ Brick Corner Type 1
Smooth Face**

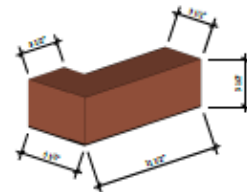

Contributed by Adrian Siverson
at R&D Masonry in Marysville,
Washington (UW Maple and Terry Halls)

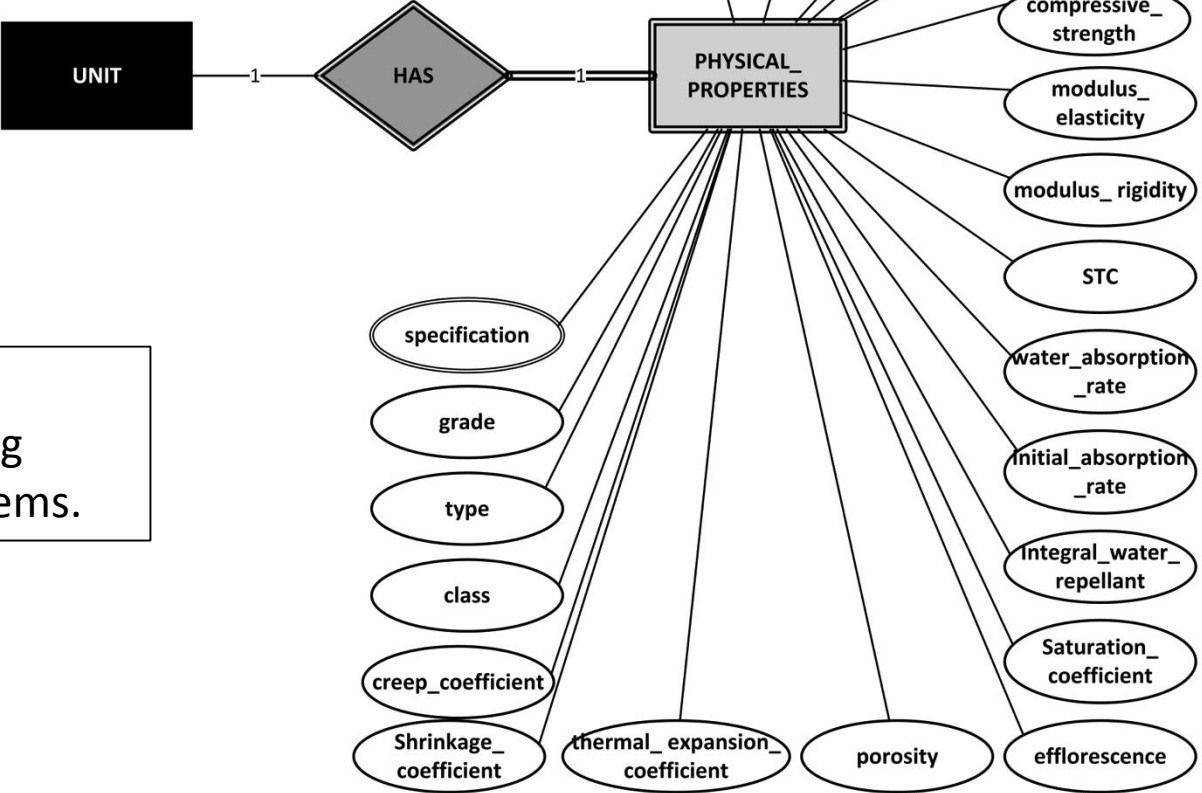
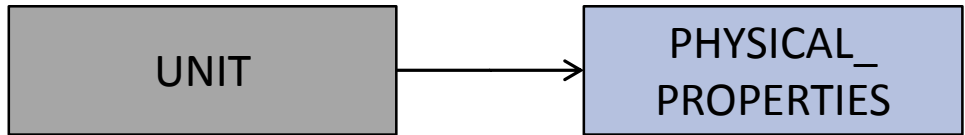

These are the properties necessary for engineering analysis of masonry systems.

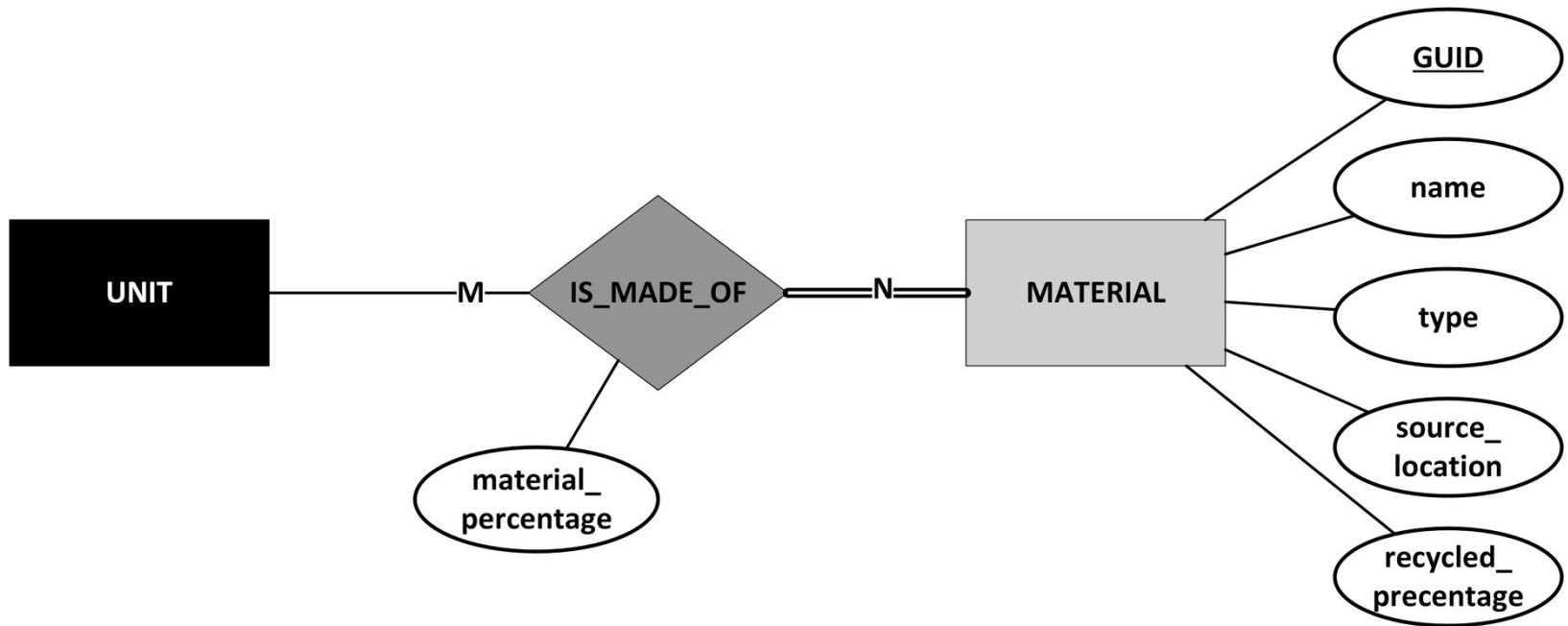
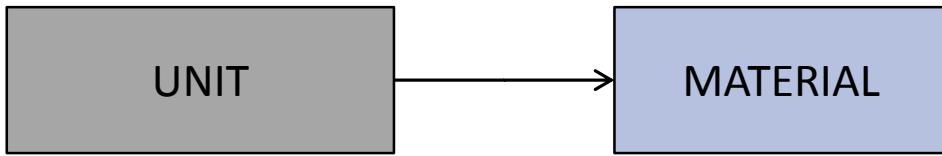

Constituent material properties are often required for LEED and other eco-scoring.

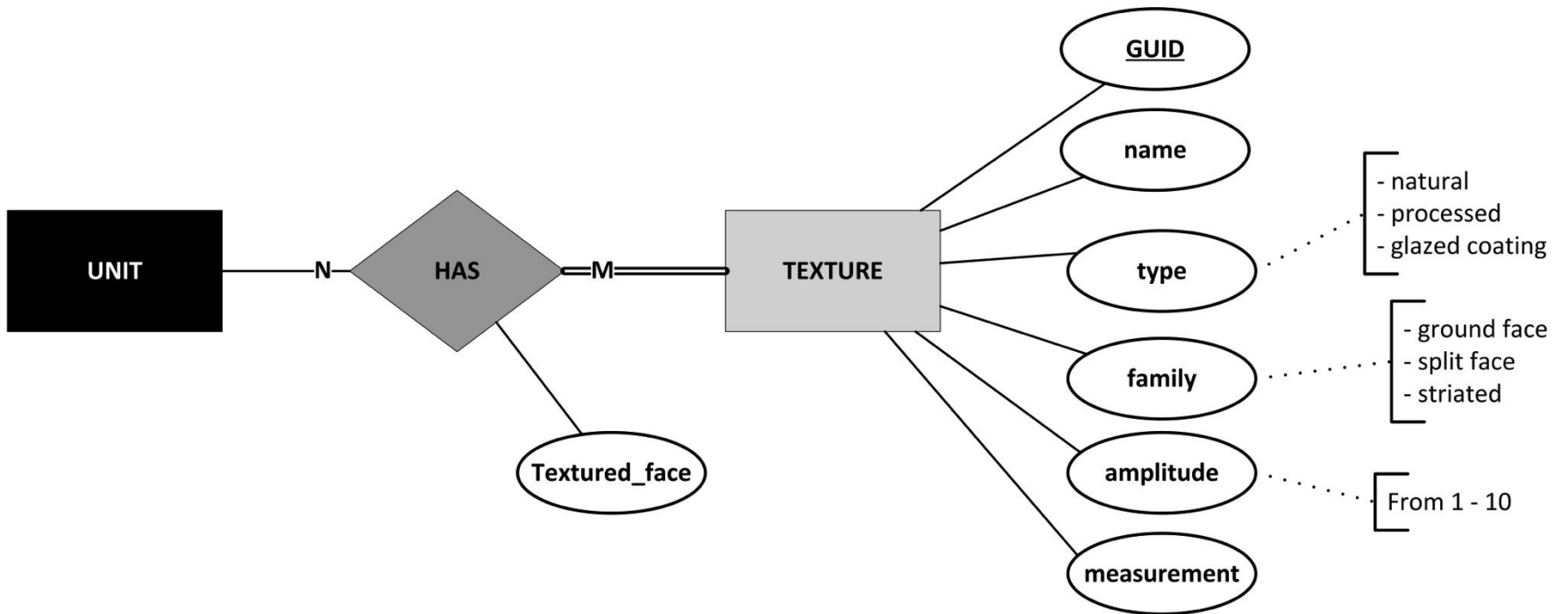
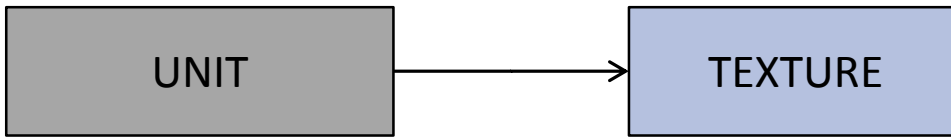

Texture Amplitude	Texture Range	Common Names	Clay	Concrete
1	Smooth	Glazed Polished Ground Face		
2		Sand Cast Sandstone Smooth		
3	Textured	Velour <u>Wirecut</u> Die Skin		
4		Matte Face		
5		Weathered Handmade Hand Molded		
6		Combed Grooved Embossed		
7	Rough	Tumbled Embossed		
8		Bark		
9		Split Face		
10		Chiseled Face Slumped		

What about ribbed units? Should we treat the ribs as geometry or texture?

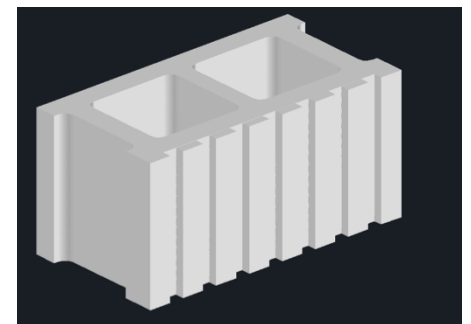

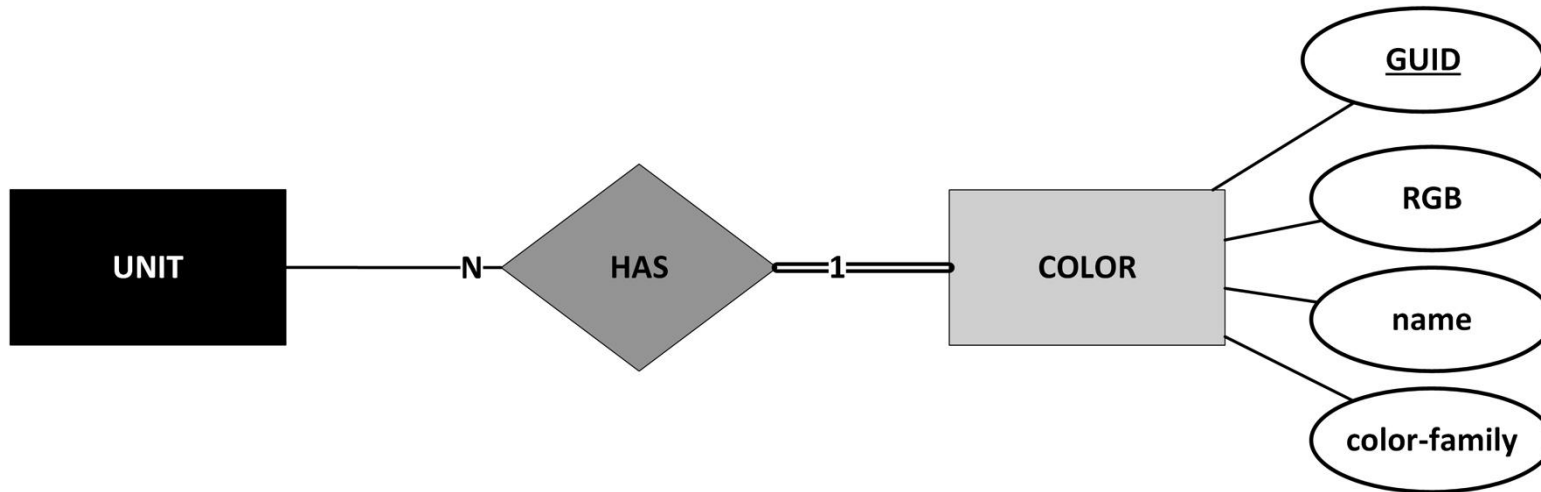
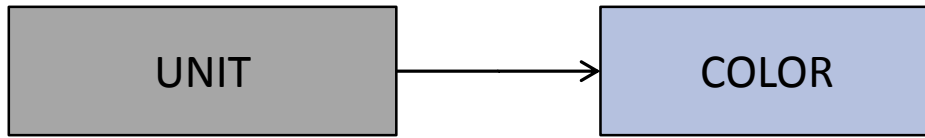

We need some help with color. Do we want color in the MUD? We believe yes.

Do we want enough color information to support photorealistic rendering? We are not sure.

Example from Interstate Brick – Atlas Copperstone
Color Analysis from Martin Krzywinski, Image Color Summarizer

http://mkweb.bcgsc.ca/color_summarizer/?analyze

“Dark Drab Red”

Hue	Saturation	Value	Red	Green	Blue
7	25	29	74	58	56



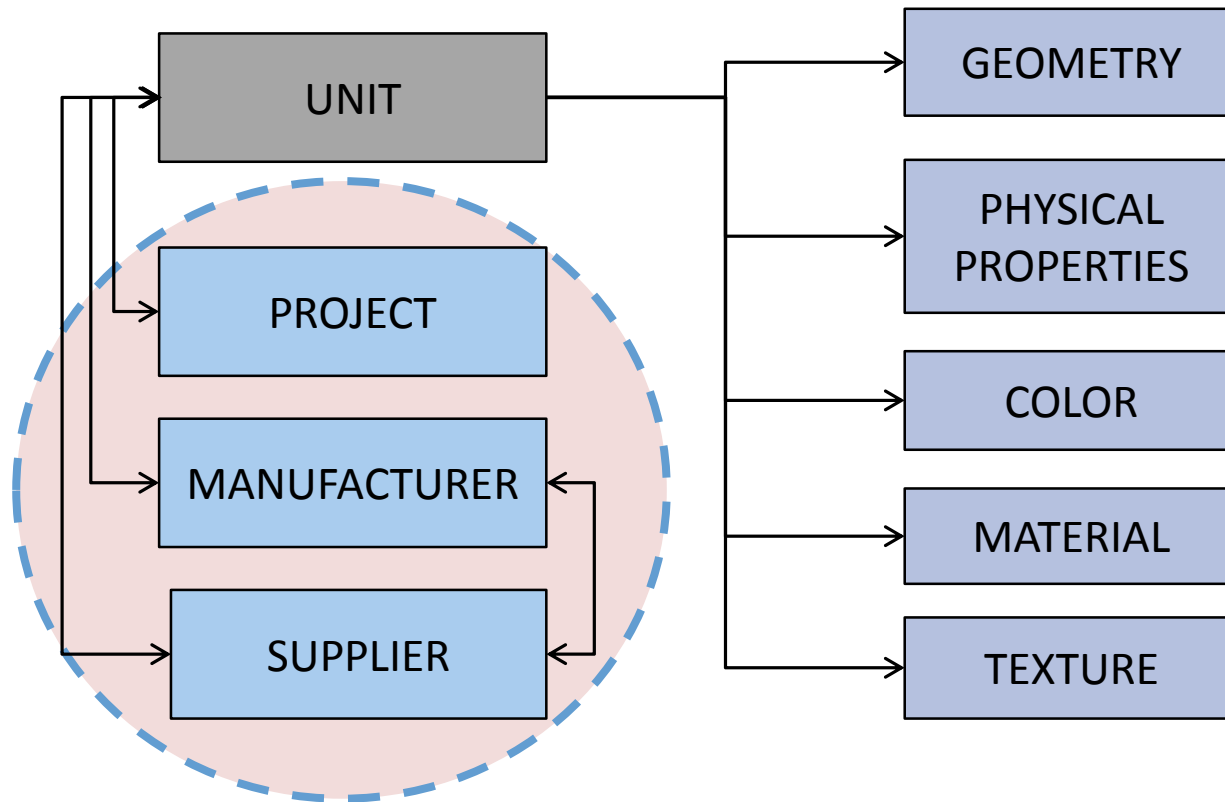

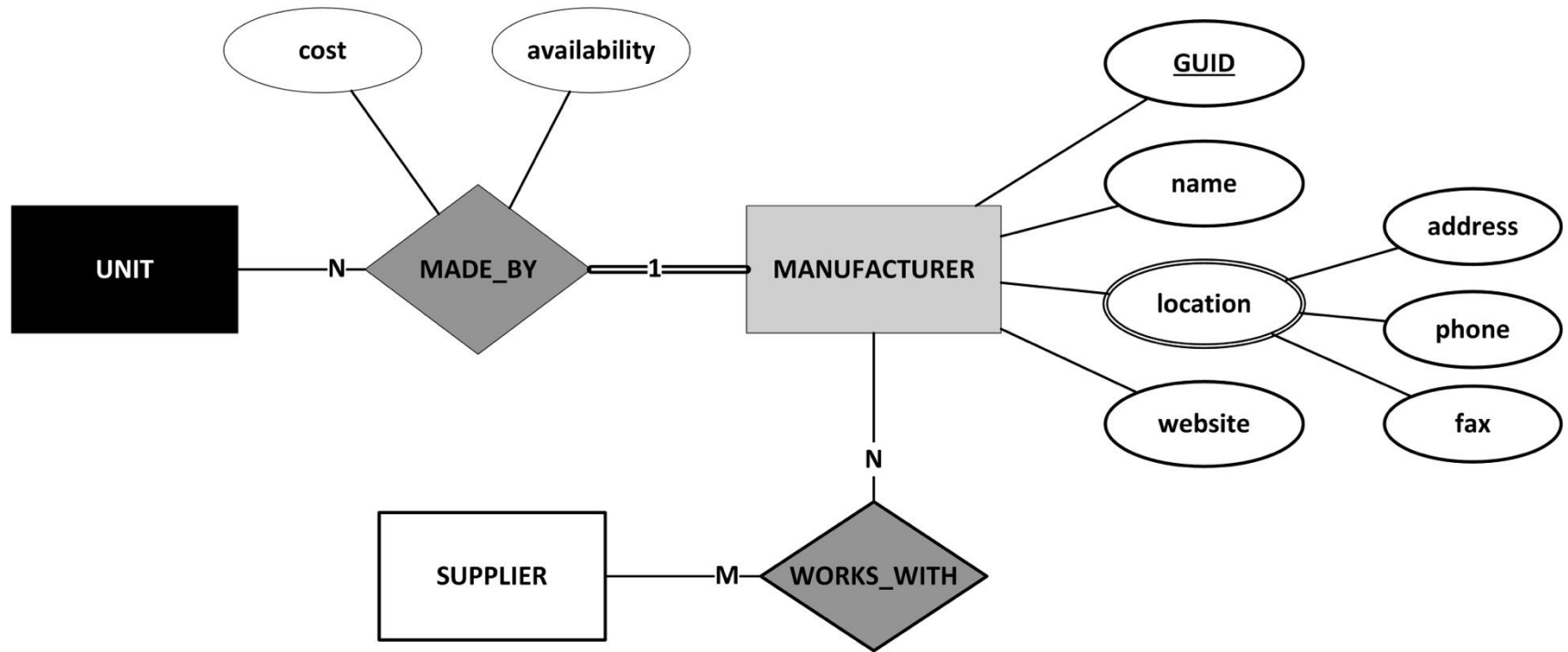
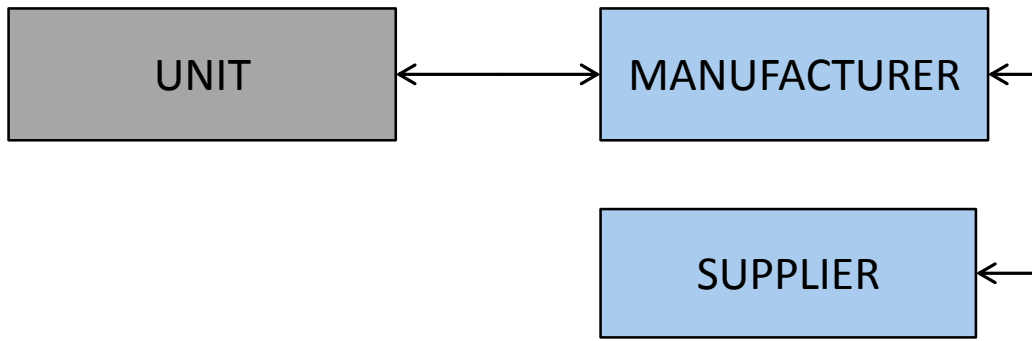

Clearly, we want the people who find your products in the MUD to be able to get in touch with you. Based on their location, they can also be put into contact with your supplier.

MUD Trial Implementation

1. Simplified Front End and Back End Application for the MUD
2. Input of around 60 units from the Masonry Supplier Working Group
3. Post the database live for your feedback
4. Simplified

MUD Trial Implementation

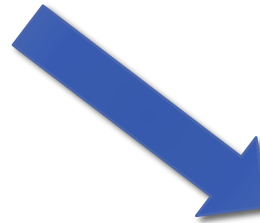
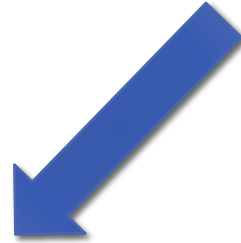
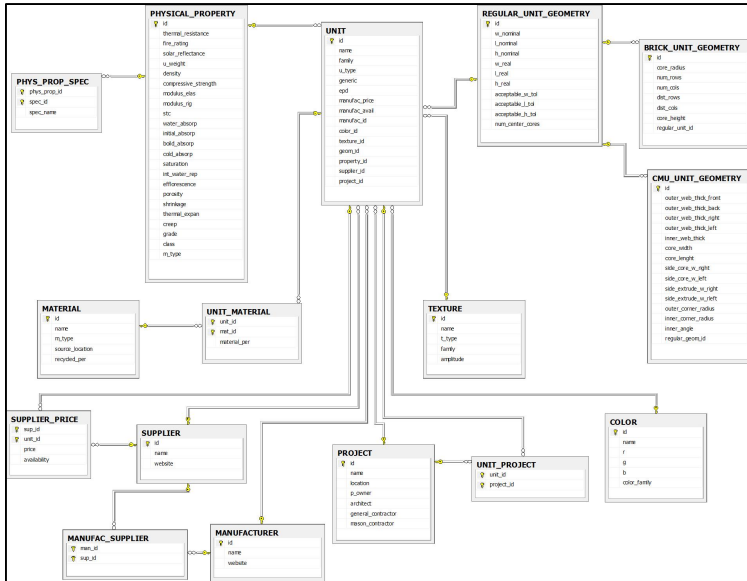

The screenshot shows the "Masonry Unit Database Data Input" form. The form is titled "BIM-M UNIT DATABASE" and includes a search bar and navigation links for "Home", "MUD Developers", and "MUD Users". The form is organized into sections with expandable/collapsible headers:

- General Unit Data**
- Manufacturer**
- Material**
- Physical Properties**
- Color**
- Texture**
- Geometry**

At the bottom, there is a "Save Masonry Unit Data" button and a "CMS By DRI" link.

The screenshot shows the "Masonry Unit Database Search Results" page. The page is titled "BIM-M UNIT DATABASE" and includes a search bar and navigation links for "Home", "MUD Developers", and "MUD Users". The page is organized into sections:

- Save Masonry Unit Data**
- Filter Search Result by:** A dropdown menu with options: "Filter By", "Attribute Types", and "Project Filter".
- Search MUD** button
- Update Results** button

At the bottom, there is a "CMS By DRI" link.

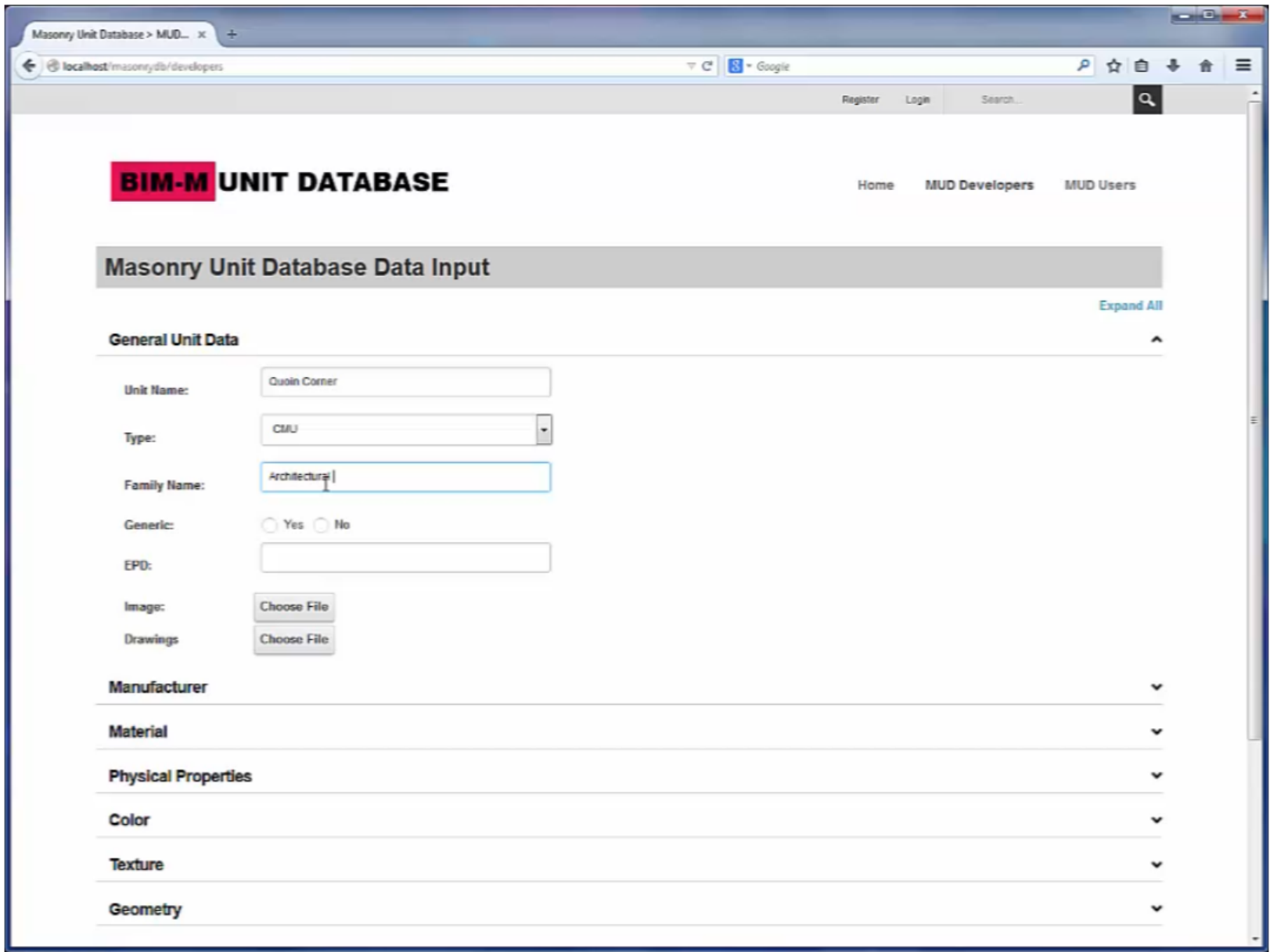

What are we doing next?

1. Trial implementation of the MUD.
2. Update the database schema based on your feedback.
3. Initial conversation with software vendors that might want to host the database: AutoDesk, ARCAT, SmartBIM . . .
4. Discussion with our masonry community software vendors and how they might link to the MUD: Tradesmen's, CADBLOX, Masonry Designer. . .

Feedback so far – we need your input

1. Need to add color range – similar to texture range
2. Need to add “bounding box” geometry in cases where we don’t care about the internal structure of the unit
3. Need to coordinate masonry unit model with the masonry wall model – insert points, mortar joints, unit orientation (stretcher, sailor, soldier, header . . .)
4. Change the name of attributes to match industry practice

How can you help?

1. Review our reports and this webinar.
2. For masonry suppliers: Take the opportunity to review your own web marketing and BIM strategy. Is it effective for your company? Would being part of an industry-wide initiative, in addition to your own marketing, be a good strategy for you?
3. Take a look at the BIM portals: ARCAT, SEEK, SmartBIM. Where should our BIM-M data be?
4. Discuss your thoughts with the GT Team. If you would like to have a one-on-one with us, we can set up a call with you.
5. As always: Tell us what your problems are.

BIM-M Contact Information

- David Biggs: biggsconsulting@att.net
- Jeff Elder: jeff.elder@interstatebrick.com
- Russell Gentry: russell.gentry@coa.gatech.edu
- Chuck Eastman: chuck.eastman@coa.gatech.edu

10. Appendix E: “Masonry Product Models for Building Information Modeling” Paper presented at 9th International Masonry Conference (2014)

Masonry Product Models for Building Information Modeling

WITTHUHN, TYLER¹; SHARIF, SHANI²; GENTRY, RUSSELL³; ELDER, JEFF⁴;

ABSTRACT:

This research focuses on the development of an infrastructure for the data representation and information exchange of masonry units in the life-cycle of a building project. This effort, entitled as Masonry Unit Model Definition (MUMD), is part of the Building Information Modeling for Masonry Initiative in North America. Specifically, this paper discusses the required information for the design, procurement, and construction with masonry products. The primary deliverable is a proposed structure for the Masonry Unit Database (MUD), a data model for the representation of all the geometric and non-geometric information needed to select, specify and purchase masonry units. In this regard, the paper discusses the classification of masonry units at two levels: at the high level in conformity with existing classification systems, and at the low level based on the similarities of materials and other attributes. Finally the paper discusses in detail the workflow of two design and construction sub-processes – structural design, and masonry procurement – with their associated BPMN and ER database models.

Keywords: Building Information Modeling, BIM, Masonry Units, Data Schema

1 INTRODUCTION

Building Information Modeling or BIM is enabling the transition from representations of buildings that contain only geometry to an information-rich environment with embedded semantics that describe the characteristics and functions of building systems. As BIM software has evolved, the need to have attribute data associated with 3D geometric models has become vital to design and construction processes. As a result, building product industries have invested significant resources into developing data models that facilitate design and construction activities through the entire building life cycle. The masonry industry in North America has committed to the development of BIM data for masonry, starting with the development of an infrastructure for the representation and exchange of information regarding masonry units [1].

This paper describes an effort to identify and organize the information needed for design, procurement, and construction with masonry. The project is denoted the Masonry Unit Model Definition (MUMD) and the primary deliverable is the proposed structure for and operation of the Masonry Unit Database or MUD. The goal is to develop a data model to capture all of the geometric and non-geometric information needed to select, specify and purchase masonry units. In the future, we envision that the MUD unit will act as a basis for digital product catalogs, web-based product selection applications, masonry e-commerce, cost-estimating and integrated with the BIM applications to be developed later in overall initiative. It is important to note that the MUD is intended to fulfill two distinct but critical roles: first to act as a data repository for the geometric description of the masonry

¹ Graduate Research Assistant, Georgia Institute of Technology, School of Civil Engineering, tyler.witthuhn@gmail.com

² Doctoral Student, Georgia Institute of Technology, School of Architecture, shani@gatech.edu

³ Associate Professor, Georgia Institute of Technology, School of Architecture, russell.gentry@coa.gatech.edu

⁴ Sales Manager, Interstate Brick, jeff.elder@paccoast.com

units including its nominal and specific geometry as well as its color and texture and second to capture descriptors needed to facilitate business and engineering processes, such as cost estimating, availability, unit of order, specifications met, etc.

2 BACKGROUND

The masonry unit database to be developed as part of this research is described generically in the literature as a building product model [2] or building object model [3]. The first step in developing a data model of this type is to determine the information needed to support a given design or construction process. Because design and construction processes are complex, with many stakeholders, we have idealized the design and construction process as consisting of 12 sub-processes so as to focus on the information needs at specific stages (Figure 1). The elucidation of data requirements from process models was first described by Eastman et al. in 2002 [4], with further examples taken from the precast concrete industry published by Sacks et al. in 2004 [5].

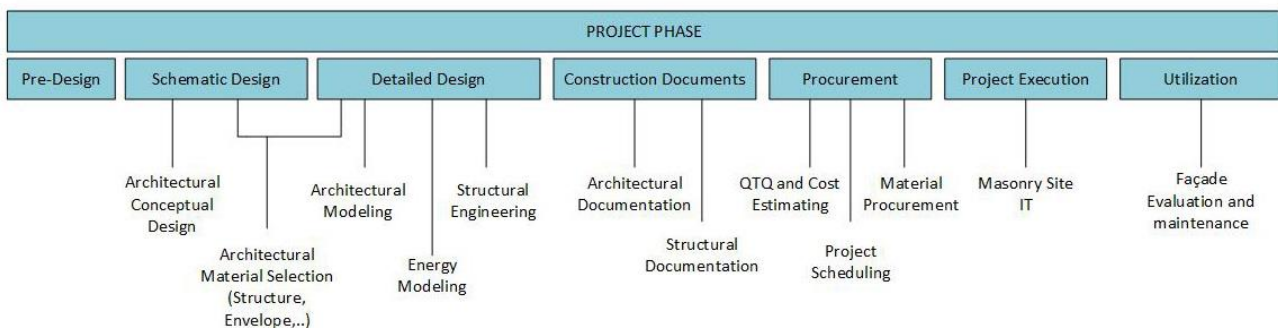

Figure 1. Masonry design and construction project timeline with project phases and proposed masonry material workflows.

3 CLASSIFICATION OF MASONRY UNITS

Once the masonry information is identified, it must be organized in ways that are machine readable by BIM systems. Therefore, a major aspect of this research is the grouping of similar data regarding masonry units. The American Society of Testing and Materials (ASTM) describes classification as: “a systematic arrangement or division of materials, products, systems, or services into groups based on similar characteristics such as origin, composition, properties, or use” [6]. At the highest level of classification, the masonry data must fit within existing classification systems for building projects and products. At this level of classification the system helps define how masonry integrates with other building systems. At a somewhat lower level, the masonry units must be ordered and grouped in a way so that units can be compared with and selected from units with similar attributes. These two levels of classification are discussed in more detail in the text that follows.

3.1 Classification of Constructed Facilities and Projects

The classification of construction information began with the development of specification formats such as MasterFormat in the United States, primarily as means to organize project manuals [7]. As these formats promote document management strategies, they do little to facilitate the organization of information in BIM systems. Construction classification systems that evolved more recently, such as OmniClass in North America [8, 9] and Uniclass in the United Kingdom provide organizational structures for projects, products, and assemblies, which can be more closely linked to BIM tools. Much of the BIM product data available today is organized according to OmniClass Table 23 (Building

Products) or Uniclass Table L (Products). The extent of the masonry classification in these systems is at a fairly high level, as can be seen in that portion of OmniClass Table 23 that pertains to masonry (Figure 2). As can be seen in Figure 2, the OmniClass Table gives a high-level view of how the masonry information might be organized, but it does not provide detailed information on the geometric or functional aspects of the masonry systems, nor a way to link masonry units to other elements and materials within masonry wall systems.

The European Standard EN 81346 for the modeling of industrial products provides elements of a classification strategy along with some relational semantics of the objects represented in the data structure [10]. According to Ekholm and Haggstrom, the Danish Building Classification system or DBK, is based on the EN 81346 and provides the most well-developed structure for organizing building product data for use in BIM [11]. The relational semantics in the DBK are limited to the following:

1. Parts with functional relations, for example: cast stone sill supports window frame;
2. Parts with compositional relations, for example, exterior wall is composed of stretcher and header units in a set pattern such as Flemish bond;
3. Parts with spatial relations, for example, sun screens are adjacent to masonry wall.

Despite the apparent robustness of the DBK system, it is not clear whether a linked classification and compositional description is desired. It may be that a pure classification system for masonry units and their accessories, along with separate compositional description within an Open BIM environment that supports IFCs [12] will provide the best way of hosting and maintaining masonry product data. The remainder of the paper will focus on classifying masonry units and associated materials and products, without focusing on the larger issues of the composing of masonry units into assemblies.

3.2 Classification of Masonry Materials at the Detailed Level

OmniClass Table 23 (Figure 2) provides a high-level approach for grouping masonry units. The primary division is by material type. For each unit type, there is a tremendous amount of geometric and non-geometric data associated with the unit. This information is discussed in detail in the sections below, organized by material types.

Concrete Masonry Units

Concrete masonry units (CMUs) are typically manufactured blocks formed out of zero-slump (very low amounts of water) concrete mix. These units are typically nominally 16 inches long and 8 inches high with widths that vary typically between 4 inches and 14 inches. In addition to material type, these nominal dimensions provide the primary means by which units are classified and referred to, but units are typically manufactured at 3/8ths of an inch less than those given. This allows for a typical mortar joint of 3/8ths of an inch to form a 16 by 8 inch section of wall.

Units can be formed as solid units or have hollow cores where rebar, grout, insulation, or plumbing and electrical chases may be placed. Typical units have 2 cores, but manufacturers produce units with up to 4 cores as well. Outside faces and ends can be manufactured with multiple different textures for a specific feel or use of the unit, and the entire concrete mix can be colored with pigments to deliver a range of colors.

Though the nomenclature for concrete masonry unit types and sizes has not been standardized – there are generally recognized names for units. In the late 1990's, the National Concrete Masonry Association (NCMA) proposed a standard nomenclature and dimensional guidance for masonry units for use across the country – but this draft standard has not been adopted [8xxxx]. A current technical note from the NCMA does provide dimensions for the most common units [9xxxx]. The NCMA also promotes a standard nomenclature for the surface finish and texture of CMUs, but it is not clear to what extent this nomenclature is used in industry [10xxxx].

Table 23		Products				
OmniClass Number	Level 1 Title	Level 2 Title	Level 3 Title	Level 4 Title	Level 5 Title	Level 6 Title
23-13 21 00		Blocks and Bricks				
23-13 21 11			Concrete Masonry Units			
23-13 21 11 11				Concrete Blocks		
23-13 21 11 13				Exposed Aggregate Concrete Masonry Units		
23-13 21 11 15				Fluted Concrete Masonry Units		
23-13 21 11 17				Interlocking Concrete Masonry Units		
23-13 21 11 19				Molded Face Concrete Masonry Units		
23-13 21 11 21				Prefaced Concrete Masonry Units		
23-13 21 11 23				Preinsulated Concrete Masonry Units		
23-13 21 11 25				Sound Absorbing Concrete Masonry Units		
23-13 21 11 27				Split Face Concrete Masonry Units		
23-13 21 13			Calcium Silicate Masonry Units			
23-13 21 15			Glass Masonry Units			
23-13 21 17			Adobe Masonry Units			
23-13 21 19			Clay Masonry Units			
23-13 21 19 11				Common Bricks		
23-13 21 19 13				Face Bricks		
23-13 21 19 15				Fire Bricks		
23-13 21 19 17				Glazed Bricks		
23-13 21 19 19				Ceramic Glazed Clay Masonry Units		
23-13 21 19 21				Clay Tile		
23-13 21 19 23				Structural Clay Tiles		
23-13 21 19 25				Clay Flue Linings		
23-13 21 19 27				Terra Cotta Units		
23-13 21 21			Masonry Anchorage and Reinforcement			
23-13 21 21 11				Masonry Reinforcing		
23-13 21 21 11 11					Continuous Joint Reinforcing	
23-13 21 21 11 13					Reinforcing Bars	
23-13 21 21 13				Masonry Ties		
23-13 21 21 13 11					Flexible Masonry Ties	
23-13 21 21 13 13					Masonry Veneer Ties	
23-13 21 21 13 15					Rigid Masonry Ties	
23-13 21 21 15				Masonry Anchors		
23-13 21 21 15 11					Masonry Veneer Anchors	
23-13 21 21 15 13					Stone Masonry Anchors	
23-13 21 23			Special Profiles for Masonry			
23-13 21 23 11				Special Masonry Shapes		
23-13 21 23 13				Masonry Sills and Thresholds		
23-13 21 23 15				Masonry Moldings		
23-13 21 23 17				Masonry Copings		
23-13 21 23 19				Masonry Quoins		
23-13 21 23 21				Masonry Cornices		
23-13 21 25			Structural Support for Masonry			
23-13 21 25 11				Lintels		
23-13 21 25 11 11					Lintel Former Units	
23-13 21 25 13				Wall Connectors and Starters		
23-13 21 25 15				Supports for Masonry		
23-13 21 25 15 11					Masonry Angles	
23-13 21 25 15 11 11						Masonry Shelf Angles
23-13 21 25 15 13					Gussets	
23-13 21 27			Ancillary Products for Masonry			
23-13 21 27 11				Embedded Flashing		
23-13 21 27 13				Cavity Closers		
23-13 21 27 15				Cavity Weep and Ventilation Units		
23-13 21 27 15 11					Cavity Weeps	
23-13 21 27 15 13					Cavity Vents	
23-13 21 27 15 15					Cavity Drainage Material	
23-13 21 27 17				Masonry Joint Materials		
23-13 21 27 17 11					Masonry Control Joints	
23-13 21 27 17 13					Masonry Expansion Joints	
23-13 21 27 19				Airbricks		

Figure 2. OmniClass classification for masonry.

Architectural Brick

Architectural or facing brick is used in veneer applications or structurally in multi-wythe walls. In common North American practice these bricks are not used in load-bearing applications, though they do carry their own weight or may help stiffen the backup wall section. Typically the bricks are attached by ties to a backup system of CMUs, steel stud, concrete, or in some residential applications wood studs. These ties bring any out of plane forces, such as wind, into the structural element of the wall system.

Brick is classified by size, method of manufacture, color and texture. The Brick Industry Association (BIA) provides information on the most common brick sizes produced in North America, but the major brick suppliers provide many thousands of special brick types [11xxxx].

Structural Brick

Structural or hollow brick is made with clay, like architectural brick, but are generally larger so as to have structural capacity in single-wythe applications. Structural bricks often have cores for reinforcing and grout. In the United States, the Western States Clay Products Association is specifically manufactured for seismic resistance. The association does not publish standard sizes of structural brick.

Cast Stone

Almost all cast stone is custom designed in a collaboration between the architect and cast stone producers for building accent pieces such as lintels, sills, and trim parts. Because the range of parts is quite variable, all pieces are generally made to order and require more complicated design drawings than a standard masonry wall. Almost all cast stone exists in a “custom” masonry workflow. This provides particular challenges for BIM systems, because generic cast stone does not exist, and the instantiation of cast stone in BIM will require a database that is flexible enough to handle complex geometries as well as variations between parts. Some aspects of these custom masonry workflows for cast stone have been developed and documented by Richard Carey, and are described in his U.S. patents (see for example: [12xxx]).

4 MATERIAL AND PRODUCT SPECIFICATIONS AND REQUIREMENTS

The building industry is driven by requirements. In North America, a vast majority of verifiable data comes from ASTM (American Society for Testing and Materials) standards. There are two distinct types of ASTM standards for masonry units, specifications and test methods. Specifications provide the requirements for a material, unit, or assembly that is to be specified in a given situation, and test methods provide the method for determining those requirements. There are many different ASTM methods that are applicable to the masonry industry. Figure 3 depicts the complex relationship of requirements for concrete masonry units, depicted as specifications and test methods related to ASTM C90: Standard Specification for Loadbearing Concrete Masonry Units [13] and ASTM C140: Test Methods for Sampling and Testing of Concrete Masonry Units and Related Units [14].

There are 14 different ASTM methods that are referenced by ASTM C90 (with many and another 13 referenced by ASTM C140). These methods create a matrix of testing procedures to determine physical and geometric properties of a CMU which are used for design in the Architectural and Structural workflows. The largest take away from this discussion is to see that a simple building material contains a vast amount of fairly complicated data to represent it, all of which must be contained in a data structure in order to effectively contribute to the design process.

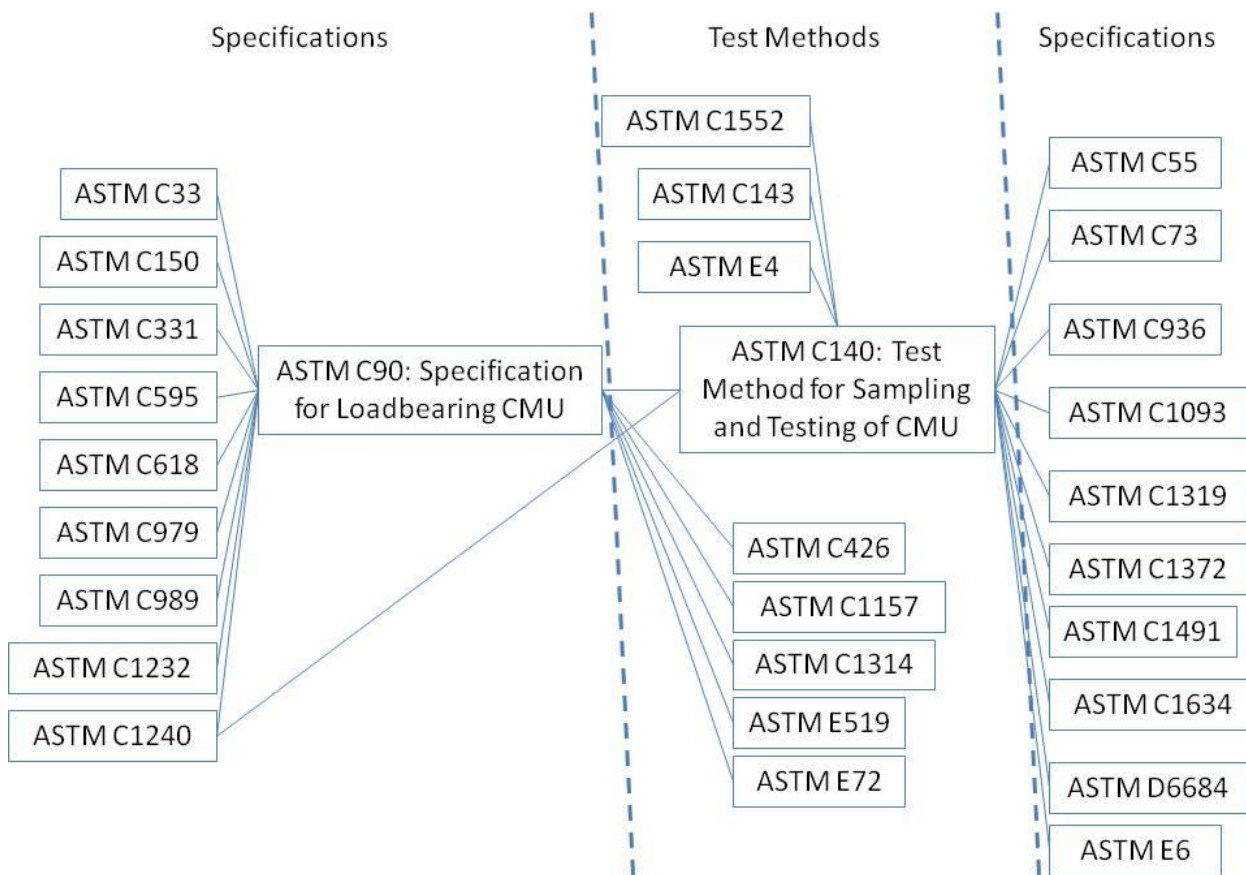

Figure 3. ASTM Specifications and Test Methods in relation to Concrete Masonry Units

5 WORKFLOW DEFINITIONS

In the context of this paper, workflows are defined as high-level business processes that involve stakeholders and exchanges of information. This research has adopted a formal method for documenting these processes using Business Process Modeling Notation or BPMN. These process models have been used successfully to document information requirements in the precast concrete and curtain wall industries [15, 16]. A typical BPMN workflow involves multiple actors set into different “swim lanes” oriented horizontally across the page with the flow of information moving from left to right. The interaction between actors is denoted an “exchange” and the information that is passed back and forth between these exchanges defines that data needed for the masonry unit database. A total of 12 process models, as defined in Figure 1, have been identified, but in the text below, we focus on three key exchanges that demonstrate the method.

In addition to the process model, it is necessary to model the structure of the data itself as the data appears as a “block” in BPMN – with no implied data schema. To that end a separate entity-relationship model is used. This ER model has the capacity to incorporate some of the essential semantic information about the masonry units in the real world, based on the data requirements of the users and functional requirements of the applications [17, 18]. The main data requirement for masonry unit database (MUD) are the geometric description of the masonry unit (nominal and specific geometry), color, and texture, as well the descriptors needed to facilitate business and engineering processes, such as cost estimating, availability, unit of order, and specifications. In addition, the proposed ER model for MUD provides the structure needed for storing, accessing and updating the

data during the course of product development to utilization cycle. The proposed ER model for MUD is represented by an ER diagram, the special diagrammatic notation associated with the ER models.

Figure 4 depicts the first workflow associated with architectural design of masonry units, and the ER model of the data associated with this workflow. As the workflow is initiated, the architect starts by browsing the web (manufacturer's web sites) and also by reviewing units and mortar samples on-hand in the firm's materials library [1.1]. The MUD is used to maintain the information on the website and could also be used to order and track the samples that are housed in the architect's materials library. Based on these initial review, the architect requests a sample with one or more masonry units with one or more mortar colors [1.2]. The product representative receives the request for the sample board [1.3] and checks with the manufacturer to determine if the masonry unit meets the architect's requirements, which could include availability, lead time for production, availability of complementary units, location of production, and price [1.4]. The manufacturer accesses internal information stored within the ERP system to retrieve product information and verify that the product meets the specification [1.5]. The manufacturer forwards this information back to the product representative who communicates back to the architect [1.6]. The architect compares this updated information with project requirements and determines if the selected masonry product(s) are acceptable [1.7]. In many cases, the process may iterate as one or more of the attributes of the masonry are not acceptable to the architect [1.8 and 1.9]. When a product selection has been made, the product representative requests a sample board from the manufacturer [1.10], who creates the sample board [1.11]. When the architect receives the sample board [1.12], it is hoped that a masonry sale has been made.

6 ADDITIONAL MASONRY WORKFLOWS

In the sections below, two additional workflows are described. These workflows are associated with structural modeling and design (by the structural engineer) and with materials procurement (by the mason contractor). The remaining workflows are still under development, and will be reported on in future work by the authors.

6.1. Structural Modeling and Design

The structural capacity of masonry walls is determined from calculations on masonry assemblies – not on units themselves. The combination of unit, grout, mortar, and rebar allows for specific axial, shear and flexural strengths to be calculated depending on the sort of design being considered. This adds a level of complexity to the MUD, as the critical values required for design do not directly translate into overall assembly strengths. Rather, the unit data must be extracted from the database and then placed into the structural analysis model along with other information regarding loads and geometric properties.

Because this document focuses on the flows of information regarding masonry units, three categories of masonry units are considered:

1. Generic masonry units are those that are described in the design documents by nominal geometry and key attributes (e.g., strength) but for which there are few or no limitations to product substitution. The standard gray CMU is a generic masonry unit.
2. Specified masonry units are those units that are specified in the design documents by brand, color and type. If the contractor wishes to substitute for a specified masonry unit, a formal change order and acceptance from the design team would typically be required. Specified masonry includes most face brick and architectural block.
3. Custom masonry units are those units that are produced specifically for the job and which typically require a shop drawing or other submittal that is approved by the design team. Custom masonry units include most cast and cut stone.

There are two basic classes of data needed from masonry units to effectively create these structural wall systems. The first is geometrical data, such as unit width, density, and moment of inertia. These values are typically taken as minimums or averages because it must be aggregated over an entire assembly, and can either be determined from testing (ASTM C140 provides unit

measurements and density), or from industry averages (NCMA TEK 14-1 gives values for moment of inertia). The MUD could conceivably calculate more accurate values due strictly to the fact that more information is at the fingertips of designers, which would create much more accurate structural calculations for masonry assemblies.

The second class of unit data required can be described as physical properties. While many different types of units can share geometric properties, physical classification is what truly separates them. The initial data would need to contain items like unit strength, modulus of rigidity, and tensile strength of masonry. Once again there are two ways currently that these values are determined, testing and reference materials. Under most circumstances, ASTM testing such as test method C140 is required to gain most physical properties, but the Building Code Requirements for Masonry Structures does provide a fair amount of reference information that is conservatively estimated from large testing projects. It is important for this data structure to allow for either reference data or values achieved by testing to be used.

In many structural design firms it is common for historical data on masonry properties to be used. Not only does this create a large disconnect between what the producer is supplying and what is being designed, but it does not utilize the masonry system fully. The most common problem is that designers choose low-strength units when higher-strength units are available at the same price. The structural information in the MUD should promote the designers use of accurate information on data strengths and geometry to effectively use the masonry capacity, which requires the producer to provide testing data early on in the design process. In order to be used as a structural masonry component, all units must be sampled and run through ASTM C90 testing. Currently it is common for that testing to not be completed until 28 days after production, when many units are already installed on the jobsite. Masonry assemblies could be much more efficient if this data was provided during the initial design phase.

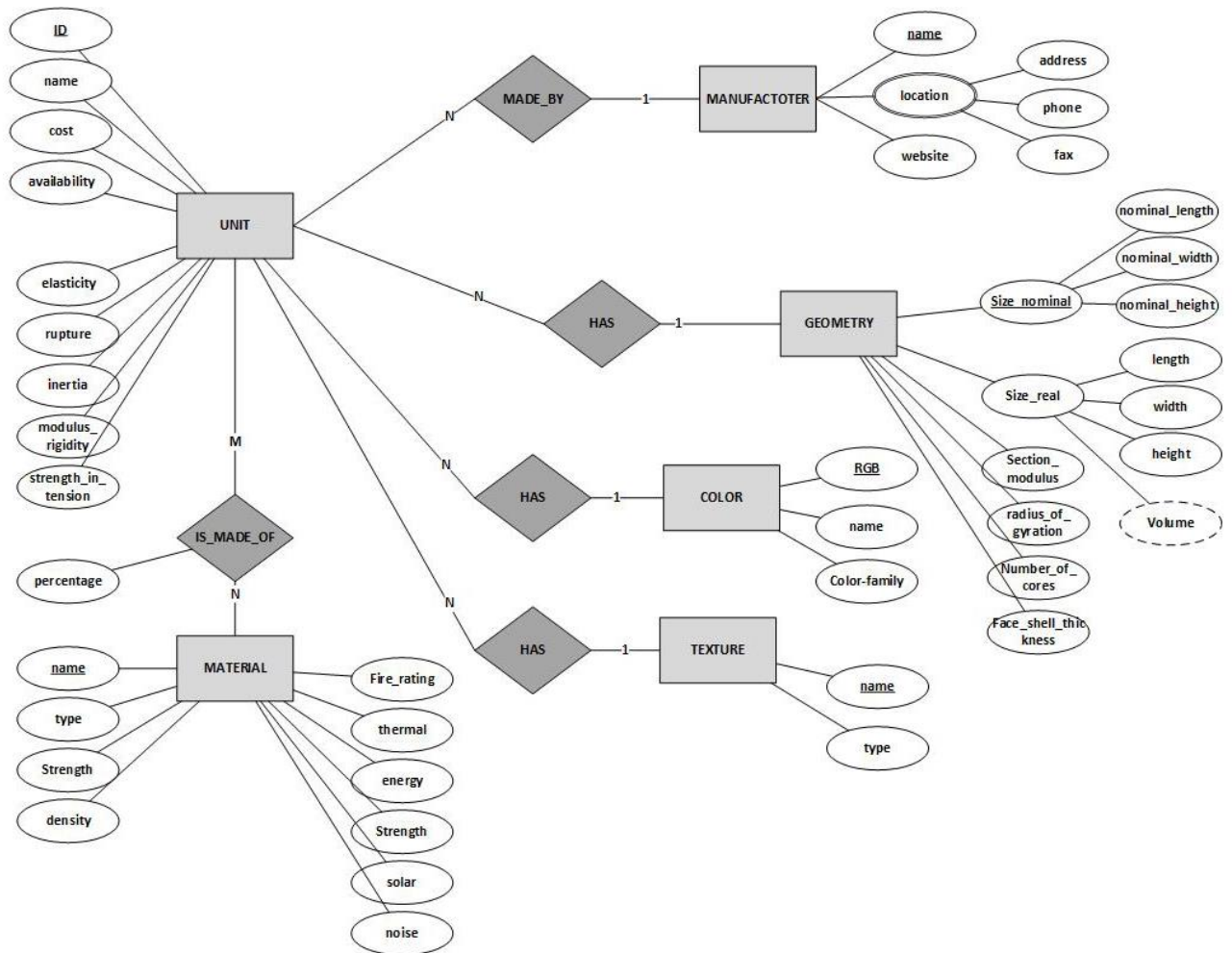
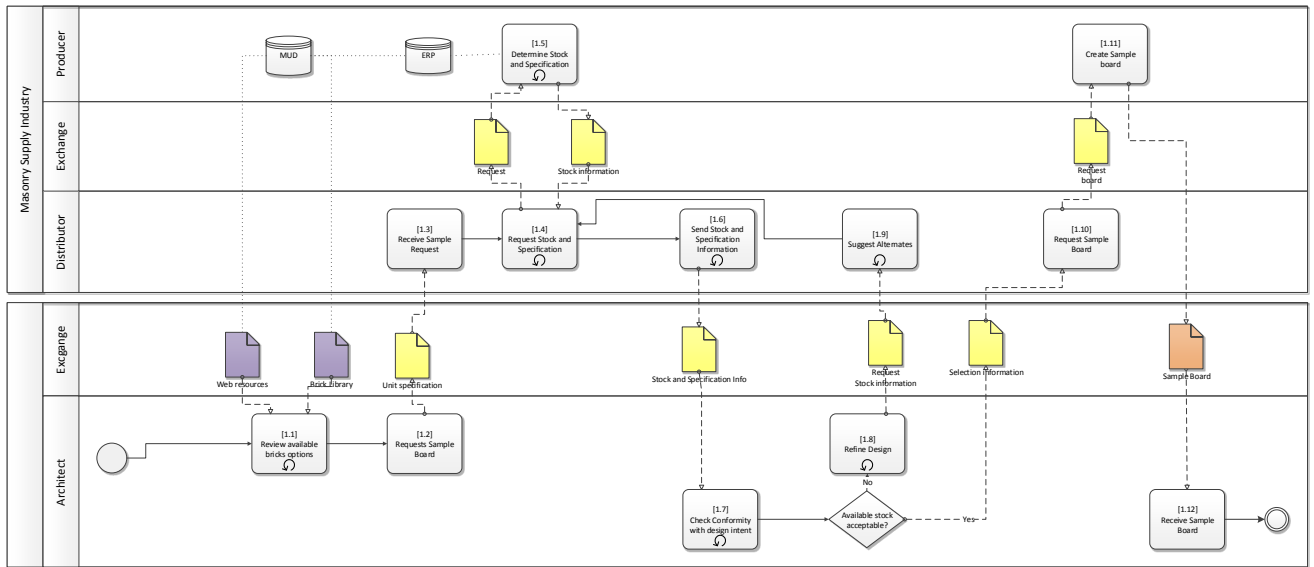

Figure 4. Architectural materials selection workflow in BPMN and associated entity relationship model for the data exchanged as part of this workflow provided by producer.

6.2. Masonry Procurement

BIM offers the ability to order and track materials electronically, from the production plant to being put in place. This is especially helpful in the masonry industry as the piece-count of products delivered to a job site generally numbers in the thousands if not higher on a typical job. In order to facilitate lean construction techniques or just on time delivery, having a robust model to support procurement and order fulfilment is important.

In the current practice, the mason contractor deals with local distributors of masonry units or in some cases directly through the masonry producer. In addition, the masonry construction industry equally uses two different methods for procurement and quantity take-offs. About half of the masonry contractors use an in-house proprietary process based on analyzing the printed drawings and specifications (2D) and subsequently enter this information into a spreadsheet for quantity and cost estimation. The other half of the industry uses specialized software tools, such as Tradesmans software, which is a dedicated cost estimation tool for masonry that maintains an internal historical pricing structure for the contractor, and also builds a graphical 3D model of the masonry walls as the walls on the project are identified. In general, the use of these tools is based on a manual analysis of the 2D contract drawings and specifications. In a future BIM-enabled environment, a quantity take-off and cost estimation workflow is proposed and described here which presents a view of how the mason contractor will interact with BIM models and the masonry unit database. The workflow illustrated here is applicable to both “generic” and “specified” masonry units. For “custom” masonry units, a more detailed workflow with additional exchanges between the mason contractor, architect, and mason supplier is required.

At the start of a BIM-enabled process for quantity take-off and cost-estimating, the mason contractor initiates a task [3.1] received from the architect. In the next step, the mason contractor queries the BIM model with the specialized BIM software for quantity take-offs to extract the data for masonry units (in terms of areas and or number of units, depending on the nature and quality of the building model). This task also inquires into the masonry unit database to identify the “generic” and “specified” units that are contained within the BIM model and determine a “match” with units found in the MUD. Finally, this initial task can be configured to return the accessories associated with the units, so that these can be captured as part of this initial data transfer.

The next task [3.3] uses the object data produced in the previous step. At this point the masonry estimator will validate the masonry materials generated from the BIM model query and complete missing information by contacting product representatives [3.4]. In some cases the product representative may have to refer to the MUD that is frequently updated by the producer to validate the selected products. In task [3.5] the estimator finishes the take-off by completing information that did not come forward from the query of the building model.

It is assumed that through a combination of automated processes, along with manual validation, the mason contractor is ready to price the masonry [3.6], for “specified” masonry it is likely that contact with the suppliers and/or producers is required [3.7 and 3.8]. It is expected that with development of necessary tools, these pricing inquiries would be automated or partially automated. For “generic” masonry, the estimator may use historical pricing – without the need for manufacturers’ quotes.

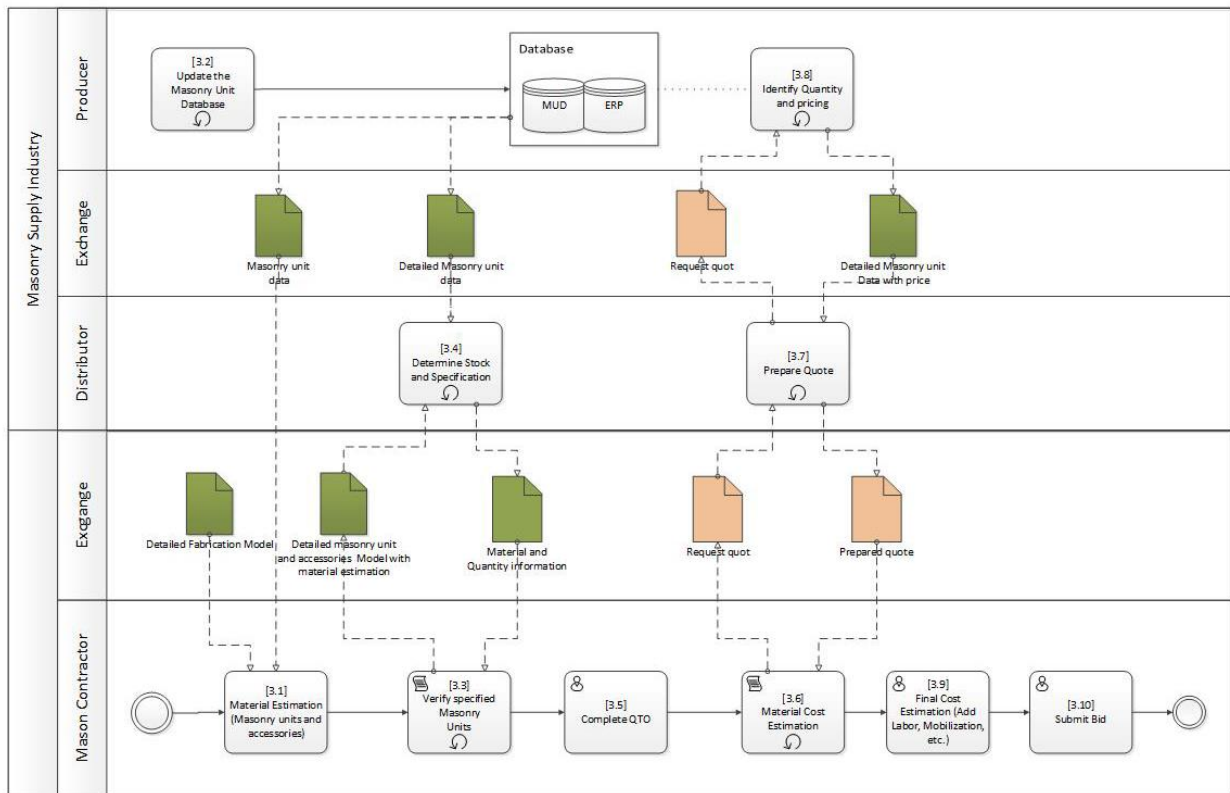

Figure 5. BPMN model for masonry unit take-offs and quoting.

SUMMARY AND CONCLUSIONS

While a database for the masonry industry would be very complex and have a host of actors, when each unit is broken down into a particular workflow with a particular ER diagram the model becomes much simpler. With accurate workflows and models developed by working with masonry industry professionals this MUD will be robust and tailored to the industry it represents.

ACKNOWLEDGEMENTS

The research reported on in this paper is sponsored by the Building Information Modeling for Masonry Initiative in North America, administered through the Charles F. Pankow Foundation. The support of the initiative and its contributors is gratefully acknowledged.

RERERENCES

- [1] Gentry, R., C. Eastman, and D. Biggs, *A Roadmap for Developing and Deploying Building Information Modeling (BIM) for the Masonry Industry*, 2013, Georgia Institute of Technology, Digital Building Laboratory: Atlanta, Georgia USA.
- [2] Eastman, C.M., *Building Product Models: Computer Environments Supporting Design and Construction*. 1999: CRC Press. 424.
- [3] Eastman, C., P. Teicholz, R. Sacks, and K. Liston, *BIM Handbook, A Guide to Building Information Modeling for Owners, Managers, Designers, Engineers, and Contractors*, ed. Wiley. Vol. 1. 2008, Hoboken, New Jersey: John Wiley and Sons Inc. 465.
- [4] Eastman, C., G. Lee, and R. Sacks. *Deriving a product model from process models*. 2002.
- [5] Sacks, R., C.M. Eastman, and G. Lee, *Parametric 3D modeling in building construction with examples from precast concrete*. *Automation in Construction*, 2004. **13**(3): p. 291-312.

- [6] *Form and Style for ASTM Standards*, 2013, ASTM: West Conshohocken, PA USA. p. 74.
- [7] Gullledge III, C.E., L.E. Beougher, M.J. King, R.P. Dean, D.J. Hall, N.M. Giglio, G.W. Bevier, and P. Steinberg, *MasterFormat 2004 Edition, 2007 Implementation Assessment*, 2007, CSI / CSC. p. 27.
- [8] Davis, D., *Updating OmniClass*, in *The Construction Specifier* 2010. p. 14-15.
- [9] Knopp-Trendafilova, A., J. Suomi, and M. Tauriainen. *Link between a structural model of buildings and classification systems in construction*. in *1st International Conference on Improving Construction and Use through Integrated Design Solutions, CIB IDS 2009, June 10, 2009 - June 12, 2009*. 2009. Espoo, Finland: Technical Research Center of Finland.
- [10] CENELEC, *DS/EN 81346, Industrial systems, installations and equipment and industrial products – Structuring principles and reference designations – Part 1: Basic rules*, 2009: Brussels and København, Denmark.
- [11] Ekholm, A. and L. Haggstrom. *Building Classification for BIM - Reconsidering the Framework*. in *Computer, Knowledge, Building: CIB W78-W102 2011: CIB International Conference 2011*. Sophia Antipolis, France: CIB.
- [12] Gokce, K.U., H.U. Gokce, and R.J. Scherer. *IFC view for product catalogues in the construction management domain*. in *European Conference on Product and Process Modelling, ECPPM 2012, July 25, 2012 - July 27, 2012*. 2012. Reykjavik, Iceland: CRC Press.
- [13] ASTM, *ASTM C90-13, Standard Specification for Loadbearing Concrete Masonry Units*, 2013, ASTM International. p. 4.
- [14] ASTM, *ASTM C140 / C140M - 13a, Standard Test Methods for Sampling and Testing Concrete Masonry Units and Related Units*, 2013, ASTM International.
- [15] Moya, Q. and O. Pons, *Improving the design and production data flow of a complex curvilinear geometric Glass Reinforced Concrete facade*. *Automation in Construction*, 2014. **38**: p. 46-58.
- [16] Jeong, Y.S., C.M. Eastman, R. Sacks, and I. Kaner, *Benchmark tests for BIM data exchanges of precast concrete*. *Automation in Construction*, 2009. **18**(4): p. 469-484.
- [17] Chen, P.P.S., *The entity-relationship model—toward a unified view of data*. *ACM Transactions on Database Systems (TODS)*, 1976. **1**(1): p. 9-36.
- [18] Elmasri, R. and S. Navathe, *Fundamentals of Database Systems*. 6th Edition ed. 2010: Addison-Wesley.

11. Appendix F: “Masonry Unit Database Development for BIM-Masonry”,
paper presented at 12th North American Masonry Conference (2015)



12th North American Masonry Conference

Masonry: Science • Craft • Art
Denver, Colorado May 17 – 20, 2015



Department of Civil Engineering
UNIVERSITY OF COLORADO
DENVER | ANSCHUTZ MEDICAL CAMPUS

Masonry Unit Database Development for BIM-Masonry

Shani Sharif¹, T. Russell Gentry², Chuck Eastman³ and Jeff Elder⁴

Abstract

This paper reports on the development of Masonry Unit Database (MUD), a data structure framework for storing the required data for digital representation of masonry units, as part of the BIM for Masonry initiative. As a requirement for the automation of BIM model creation, the available masonry data has to be in a standardized format; however, the current masonry models and data produced by the industry do not follow any standard. Consequently, we propose a data structure for MUD to represent the geometric and non-geometric data needed to select, specify and purchase masonry units. We argue that the main data required for MUD can be categorized into the internal attributes, including geometry, material, physical properties, color and texture required for activities such as unit specification, comparison, and selection, and the external attributes, including manufacturer, distributor and project required for business activities such as cost estimation, availability query, and unit of order verification. MUD is intended to facilitate the development of new BIM and other software applications for the masonry industry.

Keywords: Masonry, BIM, Relational Database, Product Model

¹ PhD Student, School of Architecture, Georgia Institute of Technology, 247 Fourth Street NW, Atlanta, GA 30332, USA, shani@gatech.edu

² Associate Professor, School of Architecture, Georgia Institute of Technology, 247 Fourth Street NW, Atlanta, GA 30332, USA, russell.gentry@coa.gatech.edu

³ Professor, School of Architecture, Georgia Institute of Technology, 247 Fourth Street NW, Atlanta, GA 30332, USA, charles.eastman@coa.gatech.edu

⁴ Sales Manager, Interstate Brick, 9780 South 5200 West, West Jordan, UT 84081, USA, jeff.elder@paccoast.com

Introduction

Building Information Modeling or BIM is enabling the transition from representations of buildings that contain only geometry to an information-rich environment with embedded semantics that describe the characteristics and functions of building systems (Eastman, Teicholz et al. 2008). As BIM software has evolved, the need to have attribute data associated with 3D geometric models has become vital to design and construction processes (Eastman 1999). As part of Building Information Modeling for Masonry (BIM-M) initiative, this research embarks on the development of Masonry Unit Database (MUD), a data structure framework for the representation and exchange of information regarding masonry units in a BIM-enabled masonry building project. The MUD is a framework for storing the required data for digital representation of masonry units, and is intended to facilitate the development of new BIM and other software applications for the masonry industry. The MUD can be compared to the database of structural steel shapes, created by the American Institute of Steel Construction (AISC) that forms the data foundation for structural steel modeling and fabrication software (AISC 2014). However, the lack of a standard system of classification across masonry industry segments as opposed to steel industry adds to the complexity of MUD development.

The first step in supporting automation for masonry BIM projects is to model information processes. Developing a masonry data model and capturing all the required information about the masonry unit, the existing data has to be represented and abstracted, which helps to reduce the complexity of the data and focus only on the required information. As Eastman asserts: “an *abstraction* of some representation is a second representation in which details of the first are purposely omitted” (Eastman 1999). Applying abstraction to data multiple times would result in an *abstraction hierarchy* that are important structures in both thinking about and organizing data for and within computers. Traversing a hierarchy from top to bottom, the single term, for example masonry unit in our case, is replaced with a set of terms that the one word characterizes, as concrete masonry unit, architectural brick, structural brick and cast stone. Every new term in the hierarchy carries attributes and relation data as well as references to even more detailed terms. At the bottom level of a hierarchy, a term is only described by a set of attributes and no reference to other terms.

Data abstraction leads to succession of data classification models such as Entity-Relationship (ER) model that links graphical information modeling with process design languages, developed by Peter Chen (Chen 1976). The power of this system is that an ER diagram is automatically translatable into a relational database schema, which is the database model for the MUD as discussed in the next sections. The ER model is a easy way to define database schema that allows definition of a common language for masonry domain experts with limited computer knowledge, and computer programmers to jointly create the masonry data model (Elmasri and Navathe 2010). Consequently, creating an abstraction hierarchy for development of a masonry unit database, the masonry domain expert knowledge has to be captured and then masonry unit data has to classified based on topological (features) and geometrical (parameters) aspects (Kalay 1989), as well as constraints that represents other product information like material properties or technology and manufacturing properties (Anderl and Mendgen 1996) in order to be represented in a ER model. In this paper, first we discuss the captured domain knowledge from masonry experts

and their special data requirements from MUD, and then describe the organization of MUD and development of database schema based on this information.

Stakeholders' Data Requirements

The masonry unit database to be developed as part of this research is described generically in the literature as a building product model (Eastman 1999) or building object model (Eastman, Teicholz et al. 2008). The first step in developing a data model of this type is to determine the information needed to support a given design or construction process. Because design and construction processes are complex, with many stakeholders, we have idealized the design and construction process as consisting of 12 sub-processes so as to focus on the information needs at specific stages (Figure 1). The elucidation of data requirements from process models was first described by Eastman et al. in 2002 (Eastman, Lee et al. 2002), with further examples taken from the precast concrete industry published by Sacks et al. in 2004 (Sacks, Eastman et al. 2004).

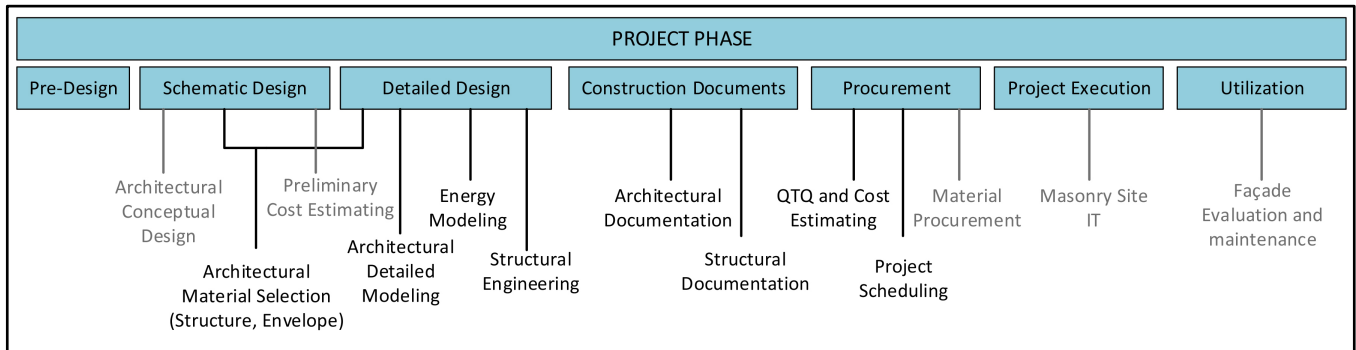

Figure 1. Masonry design and construction project timeline with project phases and proposed masonry material workflows

The content and organization of the database has been derived based on an analysis of the masonry industry from the perspective of major stakeholders in the industry, including masonry suppliers, purchasers, design professionals, contractors, and masons. Business Process Modeling Notation (BPMN) has been utilized for the representation of the masonry projects process model, which involves different stakeholders and the exchange of information among them in different stages of the project. Required data set from MUD in each of the processes and exchanges in a BIM-enabled masonry building project workflow has been described in earlier research by Gentry et al. (Gentry, Eastman et al. 2014, Witthuhn, Sharif et al. 2014). Here, the main data requirements by stakeholders is summarized:

Masonry Manufacturer: The masonry manufacturer is primarily a producer of masonry units and in this role is likely to author much of the information into the MUD. The masonry supply chain is not homogeneous – in some cases the masonry manufacturer markets and sells masonry units directly to contractors, and in other cases the manufacturer sells to a supplier – who stocks and supplies the units to contractors.

Masonry Supplier: The masonry supplier is a vendor of masonry units but does not manufacture the units. Depending on the nature of the supply chain, the masonry supplier may be responsible for inputting information into the MUD.

Building Owner/Client: The building owner or client may be interested in reviewing masonry materials that complement existing building stock. Or, in residential construction, the owner/client may be directly involved in picking the masonry materials. For this stakeholder, the primary information that the stakeholder will be looking for is appearance, and the manufacturers or suppliers who may provide the price, and availability.

Architect: The architect will interact with masonry unit information in multiple stages of the design process, with the three most important being: materials selection, detailed design, and construction documents (including specification writing). The architect requires a full range of information regarding masonry units including aesthetic, geometric, physical properties, and price.

Structural Engineer: The structural engineer is primarily concerned about the geometric, physical and mechanical properties of the masonry units. In many cases, the unit properties must be considered along with the properties of allied materials (grout, reinforcement) to develop overall properties of masonry walls. The intent is to include as much unit-level property data as necessary, so that structural design can be completed with information stored in the MUD.

Energy Analyst: The energy analyst also requires geometric and physical property data – and builds thermal characteristics of masonry walls from the thermal resistivity, surface characteristics, and density of the masonry units.

Mason Contractor: The mason contractor, like the architect, needs the complete range of masonry unit data depending on the phase of the project. In many cases the mason contractor may need appearance data in order to match existing units or to compare between units for product substitution. The mason contractor will also need information about coverage (that is, how many units are required per unit area of wall), price and availability to prepare cost estimates. It may be that the pricing data stored in the MUD will be valid only for preliminary pricing, and so workflows will be required that allow for cost-estimating to be updated during the QTO/Cost Estimating process.

General Contractor: The general contractor may have the same data needs as the mason contractor, but to a less detailed level. Many sophisticated GCs who practice “Virtual Design and Construction” are building high level of development (LOD) BIM models and these GCs are likely to access the geometric parts of the MUD in order to have the geometry of the masonry units.

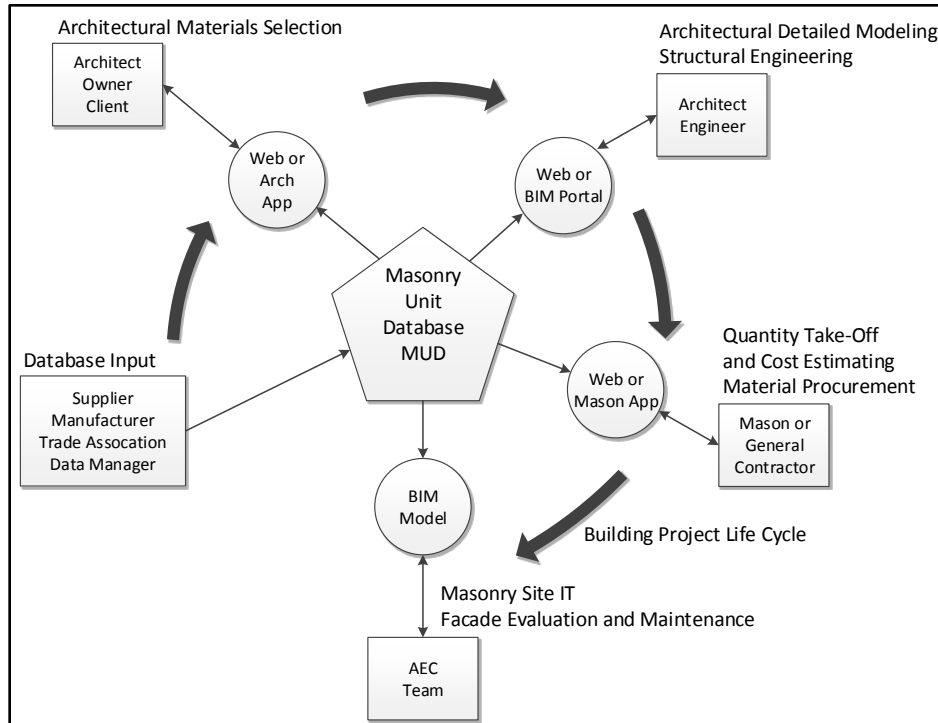

Figure 2. Stakeholder and workflow model for the MUD.

Scenarios of Use

The scenarios of use can be thought of as high-level workflows without the detail of data exchanges and data formats. There are many scenarios of use for the MUD, but four major scenarios are highlighted here

1) Material selection for aesthetics: Material selection for aesthetics involves primarily the shape, color and texture of masonry units. There are many nuances here, and in commercial construction, the selection of masonry units and associated materials (accent stone, grout, flashing) often involve the production of physical sample boards or mock-ups because digital information does not do a good job of demonstrating or promoting the “patina” that comes with masonry. In order to promote the use of the MUD for aesthetic decision making, the database will provide for storage of graphic bitmaps representing images of the finished faces of the units. The database will accommodate multiple instances of the same view, so that in an array of these randomized images will show the approximate variation across the range of units.

2) Importing geometry into BIM or CAD: In many cases, an architect (or any stakeholder attempting to create a high level of detail model) will want to insert the 3D or 2D geometry of the masonry unit into a BIM or CAD model. The database will accommodate this by providing the necessary information for parametric generation of 3D masonry units, as well as storing both 3D models and 2D drawings of the required graphic information. Common file formats for these models/drawings are DXF (AutoCad drawing exchange format), RVA (Revit), Parasolid, and SketchUp Component.

3) Wall material property determination: A structural engineer or energy analyst will need to access the MUD in order to calculate structural or thermal properties of masonry assemblies (walls). It is for this reason that the geometric properties of generic masonry units are stored as descriptors instead of as 3D solid models, and so, for example, the face shell thickness of a block can be determined directly from the database, without having to load a BIM model and query the model for that thickness. In some situations, this query will be completed through a web application that provides the information to the engineer, but it will also be easy to tie the MUD to Excel or other programs so that wall properties can be calculated automatically using third-party programs that query the MUD.

4) Determining material availability: A final scenario for the MUD is the determination of material availability. This is a typical application of databases that manage inventory, but that functionality has not been envisioned for the MUD, because at this time the MUD is not seen as a full ERP (enterprise resource planning) database for internal business processes. Nevertheless, the MUD can be a first step for a masonry customer in determining whether a given masonry unit is stocked or custom, what the minimum order quantity is likely to be, and whether it is produced within a given region of the country (which is often of interest in projects seeking a LEED rating).

Database Organization

The first step in any database design process is requirements collection, analysis and classification. The detailed data is gathered from available resources and prospective database users. In addition to data requirement specification, the functional requirements and transactions for the retrieval and update of database also have to be identified. In the next step, a conceptual schema for the database with a high-level conceptual data model has to be created (Elmasri and Navathe 2010). For MUD, we have acquired entity-relationship model (ER model) that has the ability to describe in detail the entity types, relationships, and constraints of masonry units. Conceptual schema is easier to understand and communicate with nontechnical users, as concepts do not represent implementation and storage details. Readability by nontechnical users is an important aspect that ensures the complete identification of users' data requirements and prevention of any possible requirements conflict. In addition, in conceptual schema design phase the ER model operations can be acquired to determine the high-level user queries and operations.

Here, the organization of the masonry unit database is described in detail, providing a motivation for the organization of the database, and describing the overall entity-relationship model for the database. In addition, each of the attributes to be contained in the relational database tables is described in detail.

Conceptual Schema Framework

At this level, we represent the related and required data to masonry units in an entity-relationship model (ER model), a high-level abstract method of organizing data to be later be implemented in a database application (i.e. a particular database and the associated programs that implement the database queries and updates). The ER model describes data as entities, relationships, and attributes. Entity, the basic object represented in ER model,

represents a thing in the real world with an independent existence, an object with a physical or conceptual existence. Each entity is described with particular properties that are called the attributes of the entity. Any particular entity will have value for each of its attributes, which are the major part of the data stored in the database. Different types of attributes in the ER model are: simple versus composite, single- valued versus multivalued, and stored versus derived. In ER model, relationships represent references of entities types to each other. In other words, a relationship defines a set of associations among entities. In this project, we used the Enhanced ER (EER) model which is more suitable for newer applications of database technology including databases for design and manufacturing (CAD/CAM) (Elmasri and Navathe 2010).

Masonry Overall Schema

The geometric and non-geometric masonry unit data are classified and represented in an EER model. We argue that the main data required for MUD can be categorized into the internal and external data to the units (Figure 3). Internal data to the units are represented as geometry, material, physical properties, color, and texture entities. These entities, along with their associated attributes and the relationship among them are required for activities such as unit specification, comparison, and selection. The external unit data is categorized as manufacturer, supplier and project entities, which are required for business activities such as cost estimation, availability query, and unit of order verification.

The complete MUD EER model includes these entities and their associated attributes and the relationship between the entities. Relationships in this model, such MADE_BY relating UNIT entity to MANUFACTURER entity, define a set of associations that are required for the adequate functionality of the MUD. For example the MADE_BY relationship between UNIT and MANUFACTURER entity sets would be utilized in the query of specific masonry unit production locations, or contact information. The complete network of all MUD entities, attributes, and relationships is represented Figure 4.

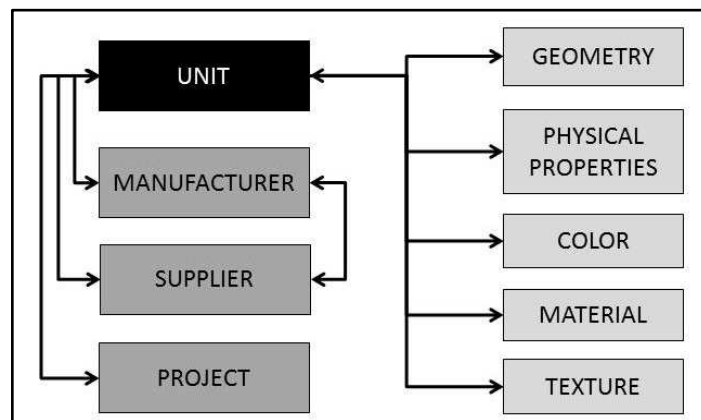

Figure 3. Main masonry unit entities to be represented in the EER model and MUD database

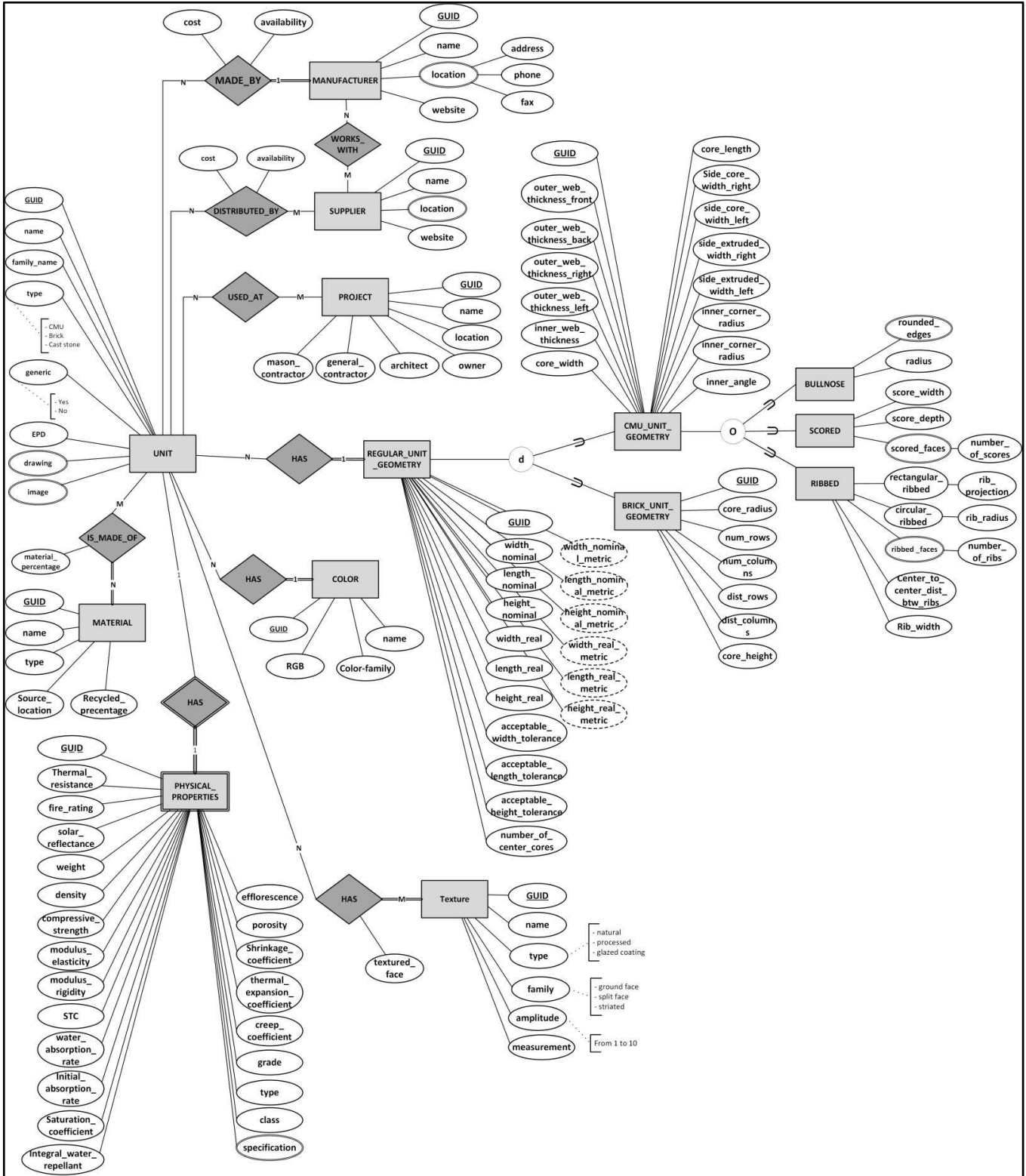

Figure 4. MUD complete EER model

Unit

The core of the MUD schema model is the UNIT entity which represents all the masonry units that is going to be represented in this database (Figure 4). There are different attributes that their values define this entity: GUID (Globally Unique ID), name, family name, type, and image and drawing. UNIT entity like all other entities in this model has a GUID attribute that is used for unique identification of each entity in the entity set. Name attribute denotes the commercial name that manufacturers specify for their masonry product. In addition, these units can have a family name that will be used for grouping of a set masonry units with similar characteristics. Type attribute at the high level classifies the masonry products and includes Concrete Masonry Unit (CMU), clay brick and cast stone masonry. The UNIT entity also stores (string) values for images or drawing file locations provided by masonry units' manufacturers.

Geometry

The most substantial entity defined in MUD is GEOMETRY, and the defined entity should be able to represent the geometry of both CMU and clay brick masonry units. The parametric geometry developed for CMU will in many instances be appropriate for structural clay units. For the development of MUD, we classify the units' geometry in three general categories: A) regular masonry unit geometry, B) special masonry unit geometry, and C) custom masonry unit geometry. The regular unit geometry is the major focus of MUD at this stage of development. The geometry attributes were developed so that a wide range of common units could be represented parametrically as regular units but also so that the database could be easily understood without the need for hundreds of parameters.

A) Regular unit geometry: the geometry of these units can be fully identified and categorized based on their parametric attributes. These units are produced by most masonry manufacturers with almost identical size and shape, although with different tolerances (Figure 5). Based on the assigned values to these attributes, each masonry unit can be identically 3D generated with the stored data in the MUD. CMU general units have parent families including stretcher, pier, corner, return corner, sash, corner sash, bond beam, conduit, lintel, open end, header, starter, and subtype groups such as bullnose, scored, ribbed (circular, rectangular). The clay bricks have two

major categories of molded bricks and extruded bricks, and with parent families including thin brick, face brick, structural brick, pavers, etc. For clay units, cores and frogs can be represented as regular units.

B) Special unit geometry: these units inherits most of the attributes from the regular unit geometry, however they have some special geometric features which is unique to these units. These units are usually produced by one specific manufacturer based on their system

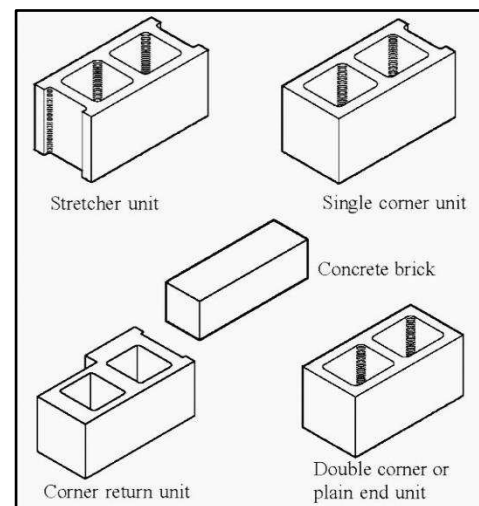

Figure 5. Typical Concrete Masonry Units that can be characterized as “regular” units.

of fabrication or particular preferences (Figure 6). Although these units can be partially represented by the parametric attributes that are defined for regular units, defining a set of parametric attributes to cover all their geometric aspects for a complete representation would be impractical, adding extensively to the complexity of the database data model. It will be up to the manufacturer whether they would like to represent their unit as a “special” unit, so that the overall shape and key features can be generated parametrically, or whether they would like to represent the unit as a custom shape.

C) Custom unit geometry: these units are custom design by the request of the project architect or they are specific to a manufacturer or have such complex geometry that they cannot be represented parametrically (Figure 7). It is likely that many of the cast and cut stone units will ultimately have to be represented as custom units. They geometry is usually complex and includes almost none of the geometric attributes of the regular masonry units. Geometry of these units is one of a kind, and as a result, parameterizing their geometric features would not be practical. Consequently, these units have to be represented with B-rep (Boundary representation) or CSG (Constructive Solid Geometry) models and to be stored as string data format or 3D files in the database.

UNIT Dimensions: Typically, CMU and clay brick units are defined with both nominal and actual dimensions. Nominal dimensions refer to unit size for planning bond patterns and modular layout with respect to door and window openings. Nominal dimensions may vary from the actual dimensions by the thickness of a mortar joint, typically 3/8 inch less than nominal dimensions but not more than 1/2 inch (9 to 12 mm). Actual dimensions refer to the real measured size of a particular unit. The actual dimensions of masonry units are usually 3/8 inch less than nominal dimensions in most masonry units, not accounting for including any adjacent or expected thickness or mortar joints, which is typical for expressions of nominal thickness. In the US, CMU have nominal face dimensions of 8 in. (20 cm) by 16 in. (40 cm), available in nominal thicknesses of 4, 6, 8, 10, and 12 in. (10, 15, 20, 25, and 30 cm). As actual dimensions are typically 3/8 in. (9) less than nominal dimensions, so that the 4 or 8 in. (102 or 203 mm) module is maintained with 3/8 in. (9.5 mm) mortar joints (Figure 8).

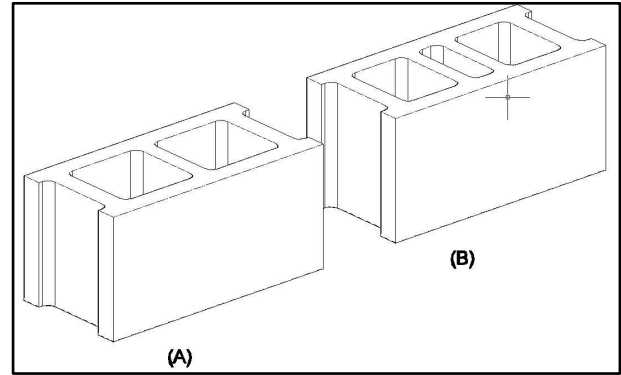

Figure 6. Masonry unit with special geometry (B) can be represented parametrically in the database as regular unit (A).

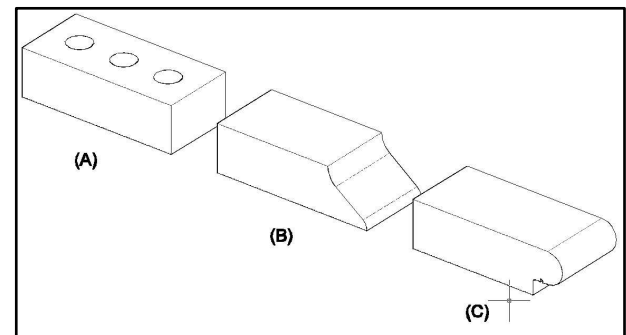

Figure 7. Custom Units (B) and (C) may be accessory units that are related to a regular unit (A).

Parametric Geometric Attributes: For the identification of masonry both CMU and clay brick units, we have classified their geometric properties into different attributes. We anticipate that based on these defined attributes all regular geometric units can be adequately represented in the database and regenerated in BIM applications. Because the geometry can be generated parametrically, the storage of the geometry is compact and all of the units do not need to be drawn in CAD. Figure 8 illustrates these attributes for clay brick units.

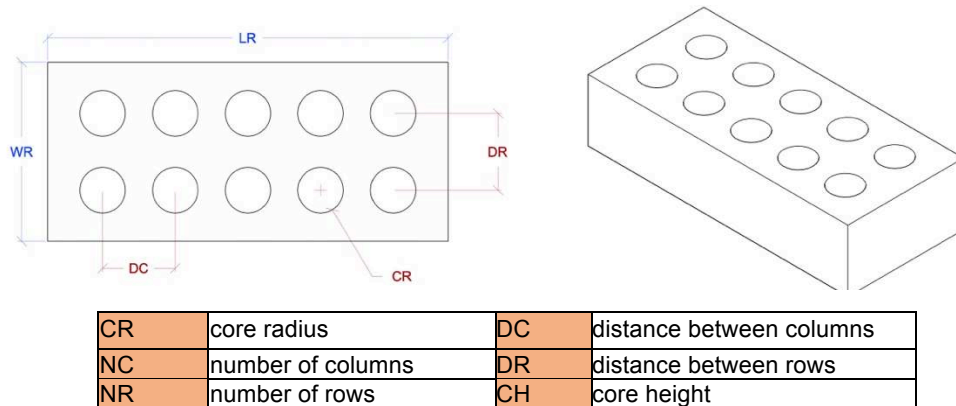

Figure 8. Attributes description, BRICK_UNIT_GEOMETRY entity.

Texture

The texture of a masonry unit is an indicator of its appearance, feel, and consistency of a surface. Texture can be defined as the pattern or configuration apparent in an exposed surface of a masonry unit, including roughness, streaking, striation, or departure from flatness. Because the texture is mapped to faces, it is necessary to map the faces and edges of the masonry unit. The convention for doing so is given in Figure 12. Texture applies to both clay and concrete masonry units, but the language used to describe the textures varies depends on the material type. When the database is extended to cast and cut stone, an even more extensive discussion of texture will need to be included. The intent here is to embody both the manufacturer’s description of texture including adjectives like “antique”, “struck”, and “rolled” as well as a numerical scale so that architects can search for units with similar texture. So, for example, searching for texture amplitude of 1 will return units with absolutely flat surfaces like glazed and ground units. Searching for a texture of 10 will return units with split, slumped and highly irregular faces.

In concrete masonry, texture is closely related to the depth of the natural aggregates and the processes such as machining polish, exposing, buffing the aggregates or glazing that have been applied to the surface of a masonry unit.

The attributes that we have defined for the specification of texture entity include texture type, texture family, texture amplitude, and texture measurement (Figure 4).

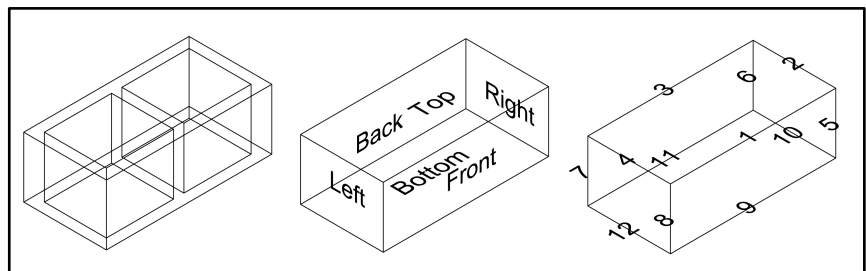

Figure 9. Naming of masonry units faces and edges.

The texture type consists of natural texture, processed texture, or glazed coating (where applicable). The texture family for CMU for example includes split-face (appearance of natural stone, rough-hewn texture with exposed aggregates), ground-face (polished surface finish produced by grinding machine), striated (random striated pattern), etc. The amplitude of the texture indicates the roughness or smoothness of the surface and is measured on the scale of 1 to 10. Measurement attributes could be represented using a quantitative assessment based on the measurement of masonry surface profiles using methods like that provided ASTM D7682, Standard Test Method for Replication and Measurement of Concrete Surface Profiles Using Replica Putty.

Color

The masonry units color is the result of color ranges in raw materials, aggregate mix, added coloring agents or glazed color in case of glazed bricks. For example the factors that influence color variations in CMU include color variation in pigments, aggregates, cements, clay, water content, degree of compaction achieved during manufacture, and for brick include kiln conditions, changes in clay materials, and atmospheric conditions such as temperature and humidity. Masonry units color variations can be standard or special order. The assigned attributes to the Color entity are RGB of the color, color name, and color family (Figure 4). The attribute color family is used to group like units together. It is also possible to add a amplitude measurement for “color uniformity”, where a brick with a large amount of color difference would have a low color uniformity.

Physical Properties

The Physical properties entity includes attributes for both mechanical properties and thermal properties of masonry units. These properties are determined based on ASTM (American Society for Testing and Materials) standards for the most part. The database represents the set of physical properties of a masonry unit that are the basis of unit selection in engineering processes. In the table below, key properties identified by the masonry industry and others identified by our research team are listed. In addition to facilitating masonry unit selection, relevant properties of units are contained in the database so that the masonry wall model database, as future part of this research, have sufficient information regarding masonry units, so that physical properties of walls, used for energy and structural analyses.

Material

Masonry units are made of combination of different raw materials created under different processes. CMU is made of a mixture of powdered Portland cement, water, sand, and gravel. Brick is made of natural clay minerals such as kaolin and shale and mixed with small amounts of additive components such as manganese and barium for production of color shades or improvement of chemical resistance. The listing of materials and their percentages is of particular interest on projects where the AEC team is pursuing LEED accreditation or trying to limit the embodied energy in the building.

In MUD, each UNIT is associated with different MATERIAL entities, each of which defined with material name, type, source location and recycled percentage (post-consumer and pre-consumer content) attributes. The relationship between UNIT and MATERIAL represents the percentage of each material used in each specific entity (Figure 4).

Manufacturer

Manufacturer entity represents the information about the masonry unit manufacturers. The attributes associated with MANUFACTURER are attributes for identifying each company and includes name, location (address, phone, fax) and website. The relationship between each UNIT entity and MANUFACTURER entity is elaborated with two additional attributes, cost and availability of masonry units produced at that company.

Supplier

Masonry suppliers are the links between masonry manufacturers and the groups that are involved in the masonry selection and purchasing for any building project. The SUPPLIER entity in MUD is identified with attributes including name, location(s), and website. The relationship between this entity and UNIT entity has additional attributes, cost and availability. The attributes assigned to SUPPLIER entity and the DISTRIBUTED_BY relationship will be used for comparison and selection of masonry suppliers based on their location, the price their offer for a specific product and the stock availability. In addition, the SUPPLIER entity has an additional relationship, WORKS_WITH, which relates it to the MANUFACTURER entity.

Project

PROJECT entity represents the building projects that the masonry units have been used in. Each project entity is defined by these attributes: name of the project, owner of the project, and project location.

Conclusion

As the test case for this study, we intend to implement the database with a small selection of masonry units – in an SQL data management system such as MySQL as the backend, with an initial set of data with about 50-60 masonry units, accompanied by a simplified front end as a website for data input and query. With this test MUD, the potential for hosting the database, and its management and access would be assessed, and the connection to software vendors' databases such as Tradesmen's, CADBLOX, Masonry Designer would be studied. This test MUD is intended to be reviewed by the current BIM-M community, and especially masonry suppliers and software providers. In addition, we recognize that the custom masonry workflow is not fully illustrated in this work at this time, as the focus has been on regular units. The feedback from the cast and cut stone communities would provide the chance to represent these materials in MUD.

References

- AISC. (2014). "Steel Construction Manual Shapes Database - AISC." from <http://www.aisc.org/content.aspx?id=2868>.
- Anderl, R. and R. Mendgen (1996). "Modelling with constraints: theoretical foundation and application." Computer-Aided Design 28(3): 155-168.

- Chen, P. P.-S. (1976). "The entity-relationship model—toward a unified view of data." ACM Trans. Database Syst. 1(1): 9-36.
- Eastman, C. (1999). Building Product Models: Computer Environments Supporting Design and Construction, CRC Press.
- Eastman, C., G. Lee and R. Sacks (2002). Deriving a product model from process models. ISPE/CE2002
- Eastman, C., P. Teicholz, R. Sacks and K. Liston (2008). BIM Handbook, A Guide to Building Information Modeling for Owners, Managers, Designers, Engineers, and Contractors. Hoboken, New Jersey, John Wiley and Sons Inc.
- Elmasri, R. and S. Navathe (2010). Fundamentals of Database Systems, Addison-Wesley Publishing Company.
- Gentry, T. R., C. Eastman, S. Sharif, T. Witthuhn and J. Elder (2014). Masonry Unit Model Definition. Building Information Modeling for Masonry, Phase II Project. G. I. o. Technology, Charles Pankow Foundation.
- Kalay, Y. E. (1989). Modeling objects and environments, John Wiley & Sons, Inc.
- Sacks, R., C. M. Eastman and G. Lee (2004). "Parametric 3D modeling in building construction with examples from precast concrete." Automation in Construction 13(3): 291-312.
- Witthuhn, T., S. Sharif, R. Gentry and J. Elder (2014). Masonry Product Models for Building Information Modeling. 9th International Masonry Conference Guimarães, Portuga